

Every effort has been made to assure the accuracy of product descriptions in this catalog at the time of printing. SPX FLOW US, LLC reserves the right to modify or discontinue products without prior notice.



Torque Wrenches 10-33



Tensioners 35-45



Other Tools 47-57

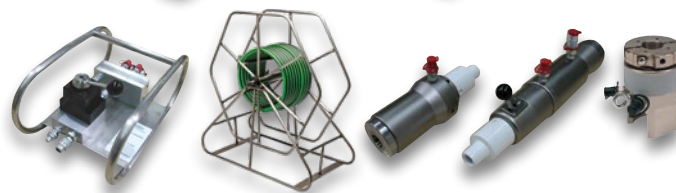

Subsea Tools 59-67



700 Bar (10,000 psi) Pumps 69-89



1,500 Bar (21,750 psi) Pumps 91-100



Accessories + Software 101-115



Resources 117-135

NUMERIC INDEX

9040, 9042DG.....	51, 104-106	P59, P59L, P59F.....	88-89	TWLC2-RB - TWLC30-RB.....	30
9040E.....	51, 106	P59L-1500, P59L-1500G.....	98-99	TWLC2-RP - TWLC30-RP.....	30
9042DG1500.....	103, 105	PA60A.....	6-7, 71, 74-75	TWLC2 - TWLC30.....	24-25
9072.....	102, 104	PA60APF5FMP.....	75	TWR2-041036 - TWR8-100095.....	28
9616.....	107	PA60APF5FMPR.....	75	TWR15-070065 - TWR30-500463.....	29
9636 - 9638.....	107	PA60APF5FP.....	75	TWSD1-ERA11 - TWSD25-ERA3.....	20
9639, 9640.....	107	PA60APF5FPR.....	75	TWSD1-LRA - TWSD25-LRA.....	21
9642.....	51	PE8LXX3L, PE8PXX3L.....	92-93	TWSD1-RP - TWSD25-RP.....	21
9645 - 9647.....	107	PE39PED1BPR.....	76-77	TWSD11 - TWSD25.....	18-19
9670.....	51, 106	PE39PED1PR.....	77	TWSIA088 - TWSIA238,	
9682.....	51	PE39YED1BPR.....	77	TWSIB088 - TWSIB425,	
9764, 9764E.....	51, 106	PE39YED1PR.....	77	TWSIC163 - TWSIC463,	
9796 - 9800.....	51, 106	PE45.....	6-7, 71, 72-73	TWSIF313 - TWSIF613.....	23
9797.....	106	PE55TWP-4-220-BS.....	6-7	TWSL.....	32
9798.....	50-51, 106	PE55TWP-4-BS.....	78-79	TWSL4-TWSL8.....	32-33
9799.....	106	PE55TWP-4-CF-BS.....	78-79	TWSL4-046 - TWSL4-080.....	33
9800.....	106	PE55TWP-220-BS.....	78-79	TWSMA022 - TWSMA050,	
2001772.....	103, 105	PE55TWP-BS.....	78-79	TWSMB022 - TWSMB110,	
2002278.....	103	PG120TWP.....	82-83	TWSMC041 - TWSMC120,	
2008082, 2008083.....	51	QRNAS010001 - QRNAS080005.....	60	TWSMF080 - TWSMF150.....	23
2008410.....	51-52	QRNAS020003.....	60, 65	WDD1-M30 - WDD5-M42.....	43
2008547.....	103	RWP55-4-BS.....	84-85	WSD1-M30 - WSD5-M42.....	44
2008548.....	105	RWP55-4-BS-R.....	84-85	WSL1-10, WSL1-11.....	45
2008549.....	104	RWP55-BS.....	84-85	WSL1, WSL2.....	45
2008550.....	104	RWP55-BS-R.....	84-85	WSL2-125, WSL2-138.....	45
251410, 251411.....	102, 104	SB15.....	51-53	WSS1-10, WSS1-11.....	45
252364, 252365.....	102	SFPAD000002.....	65	WSS1, WSS2.....	45
3000610.....	77	SFPAS000001.....	64	WSS2-125, WSS2-138.....	45
308022.....	54	SFPAS000003, SFPAS000008.....	64	X1A1-PT.....	86-87
308840.....	54	SFPQA000H00 - SFPQA000V00.....	65	X1E1-PT, X1E2-PT.....	80-81
350549.....	56	SFPSA000H00 - SFPSA000V00.....	65		
350550.....	56	SFPTA000H00 - SFPTA000V00.....	65		
350822.....	56	SFPWA000C00 - SFPWA000V00.....	64		
350823.....	56	SFPWR190005.....	64		
351985.....	54	SFPWR220005.....	64		
DFTAS000001.....	15-16, 20	SHRAS010002.....	63		
DFTAS000002.....	15-16, 19-20, 32, 33	SRTAS000001 - SRTAS080001.....	38-39		
EHN1-TC - EHN23-TC.....	57	SRTAS000002 - SRTAS080014.....	38-39		
ENSAS010001 - ENSAS040003.....	49	SSTAS010001 - SSTAS080001.....	60-61		
ENSBL010001 - ENSBL040001.....	48	STDFA000167.....	65		
FK59.....	89	STDHC00025.....	103		
FLS15, FLS15-ST.....	50-53	TWD11-017 - TWD25-070 &			
HCUCV070001.....	63, 66, 104	TWD11-063 - TWD25-275.....	22		
HFS3A, HFS6A.....	56	TWH06E-SS.....	104		
HHAMA15002.....	105	TWH100-SS.....	104		
HHAMA150001.....	103	TWH15-BS, TW20-BS, TWH50-BS.....	102		
HHAMA150002.....	67	TWH3E, TWH6E, TWH10E.....	102		
HHAMA150003.....	103	TWH30E-SS.....	104		
HHAMA150004.....	103	TWHC1-ERA1 - TWHC1-ERA3.....	16		
HL1M.....	105	TWHC1-LRA - TWHC6-LRA.....	17		
HL3M.....	105	TWHC1-RP - TWHC6-RP.....	17		
HL5M.....	105	TWHC1 - TWHC50.....	14-15		
HL8M.....	105	TWHC3-ERA1 - TWHC3-ERA3.....	16		
HL10M.....	105	TWHC6-ERA1 - TWHC6-ERA3.....	16		
HL13M.....	105	TWHCHD01-017 - TWHCHD06-041 &			
HL30M-DL.....	105	TWHCHD01-063 - TWHCHD06-163.....	22-23		
HNS150.....	54	TWL2-026 - TWL2-188.....	26		
HNS150A.....	54	TWL2-032 - TWL2-060.....	28		
HNS225.....	54	TWL4-033 - TWL4-313.....	26		
HPSTP150004.....	105	TWL4-041 - TWL4-080.....	28		
HPUTP150001K.....	91, 94-95	TWL8-049 - TWL8-313.....	26		
HPUTP150002K.....	67, 91, 96-97	TWL8-060 - TWL8-100.....	28		
HPUWP070010K.....	63, 66	TWL15-062 - TWL15-463.....	27		
HS2000, H3000.....	55	TWL15-070 - TWL55-155.....	29		
MRTAS010001 - MRTAS070008.....	40-41	TWL30-080 - TWL30-463.....	27		
P19L.....	51-53, 88-89	TWL30-122 - TWL30-500.....	29		
P19, P19L.....	88-89				

A

ACCESSORIES

Hose Assembly - CE Hydraulic	106
Hydraulic Fluids	107
Hydraulic Hose Assembly - IJ100	106
Splitters & Spreaders	106
Standard Twin-line Topside Hoses	102
Subsea Tension Hoses	105
Subsea Torque Wrench Couplers	104
Subsea Twin-line Hoses	104
Tensioner Hoses	103
Topside Tension	103
Topside Torque Wrench	102
Application Data Sheet	130

C

COUPLERS

Coupler Explanation	100
Spreaders & Splitters Couplers	106
Subsea Tension	105
Subsea Torque Wrench Couplers	104
Topside Torque Wrench	102

CUSTOM PRODUCTS

Ring Tensioner	134
Spanner Link & Reaction Roller	134
Threaded Piston Tensioners	135
TWHC Accessories	135

F

Flange Spreader - FLS15	50-51
Fluids, Hydraulic	107

H

HAND PUMPS

Hand Pumps Hydraulic - P Series	88-89
Handle, Torque Wrench	14-16, 19-20
High Pressure Hand Pump	98-99

HOSES

Standard Twin-line Topside Hoses	102
Subsea Hoses Twin-line	104
Subsea Tension Hoses	105
Tensioner Hoses	103
Hydraulic Bolting Safety	128-129

I

Infinity Series Air Pump - PA60A	74-75
Infinity Series Electric Pump - PE45	72-73

M

Measurements/Specifications	132
Manufacturing Standards	132

MEASUREMENTS/SPECIFICATIONS -

Conversion Formulas

Decimal & Millimeter Equivalents	118
SI* Conversion Formulas	119
Torque Requirements for Imperial Bolts	124
Torque Requirements for Metric Bolts	125
TWHC High Cycle Hydraulic Torque Wrench Pressure - Torque Conversion Chart	122
TWLC Low Clearance Hydraulic Torque Wrench Pressure - Torque Conversion Chart	121

TWSD Square Drive Hydraulic Torque Wrench Pressure - Torque Conversion Chart	120
--	-----

MEASUREMENTS/SPECIFICATIONS -

Reference Tables

Recommended Bolt Stresses for ANSI B16.5, BS1560 and MSS SP44 Flanges	123
Typical Co-Efficient Values for Bolt Lubricants	123

N

NUT

EHN Top Collar	57
----------------	----

NUT SPLITTERS

ENS Hydraulic Nut Splitter	48-49
HNS Hydraulic Nut Splitter	54

O

Oil, Hydraulic	107
----------------	-----

P

Powerthon™ Lifetime Warranty	133
------------------------------	-----

PUMPS -1,500 bar (21,750 psi)

Electric Pump - PE8	92-93
High Flow & Subsea Tensioner Air Power Pack - HPUTP-2	96-97
High Pressure Hand Pump	98-99
Standard Flow Tensioner Air Power Pack - HPUTP-1	94-95

PUMPS -700 bar (10,000 psi)

Bolting Pump Summary Chart	70
Classic Series Air Hydraulic Pump - RWP55-BS	84-85
Classic Series Electric Hydraulic Pump - PE55TWP-BS	78-79
Classic Series Gas Hydraulic Pump - PG120TWP	82-83
Compact Electric Torque Wrench Pump - PE39	76-77
Hand Pumps Hydraulic - P Series	88-89
Infinity Series Air Pump - PA60A	74-75
Infinity Series Electric Pump - PE45	72-73
Legacy Series Air Hydraulic Pump - X1A1-PT	86-87
Legacy Series Electric Hydraulic Pump - X1E1-PT	80-81
The ISP Advantage	71
PUMP SELECT GUIDE	6-7

R

Rental, Calibration & Service Centers	114-115
---------------------------------------	---------

RESOURCES

Application Data Sheet	130
Bolting Pump Summary Chart	70
Manufacturing Standards	132
Measurements/Specifications - Conversion Formulas	118-125
Powerthon™ Lifetime Warranty	133
Pump Select Guide	6-7
Bolt Tensioners - How it Works	126-127
The ISP Advantage	71
Training	112-113

S

SOFTWARE

Advisor Bolt Load Calculator	111
FlangePro	
Flange Management Systems	108
Splitters & Spreaders	106

SPREADERS

Flange Spreader - FLS15	50-53
Pipe Flange Spreader - HFS	56
Spreader - HS	55

SUBSEA ACCESSORIES

High Flow Bolt-Tensioning Pump - HPUTP150002K	67
High Flow Pump - HPUWPO70010K	66
Remote Diver Control Valve - HCUCV070001	63, 66, 104
Single & Twin-line Hose Reels	66

SUBSEA TENSIONERS

Flange Pullers - SFP	62-65
Stud Tensioner - SST	60-61
Subsea Accessories	66-67

T

TENSIONERS

Compact Tower Wind Tensioners - WSD	44
Foundation Wind Tensioners - WSS & WSL	45
Manual Return Bolt Tensioner - MRT	40-41
Spring Return Bolt Tensioner - SRT	37-39
SRT Advantages	36
Subsea Stud Tensioner - SST	60
Up Tower Wind Tensioners - WDD	43
Wind Tensioners - WD/WS	42

TORQUE WRENCHES

Adapters & Sockets	22-23
Custom Accessories - TWLC	31
Drive Bodies - TWLC	28-29
Extended Reaction Arms - TWHC	16
Extended Reaction Arms - TWSD	20
Handles - Torque Wrench	15-16, 19-20
High Cycle Torque Wrench - TWHC	14-15
Long Reaction Arms - TWHC	17
Long Reaction Arms - TWSD	21
Low Clearance Torque Wrench - TWLC	24-25
Low Clearance Links - TWLC	26-27
SlimLine Links - TWSL	33
Low Clearance Reducers - TWLC	28-29
Reaction Arms - TWLC	30
Reaction Arms - TWSD	20
Reaction Bar - TWLC	30
Reaction Pad - TWHC	17
Reaction Pad - TWSD	21
Reaction Paddles - TWLC	30
SlimLine Torque Wrench - TWSL	32
Square Drive Torque Wrench - TWSD	18-19
Torque Wrench Overview	12-13
Torque Wrench Selection Guide	11

TRAINING	112-113
----------	---------

PUMP SELECT GUIDE

INSTRUCTIONS

This flow chart has been designed to guide you to the family of hydraulic pumps that is most likely to be the final selection for a given application.

1. Follow the flow chart to determine the product family that is most likely best suited for a given application.
2. Review the product information for the product family to ensure the specified pump meets all of the requirements of the application.
3. Select the item code of the pump to order.

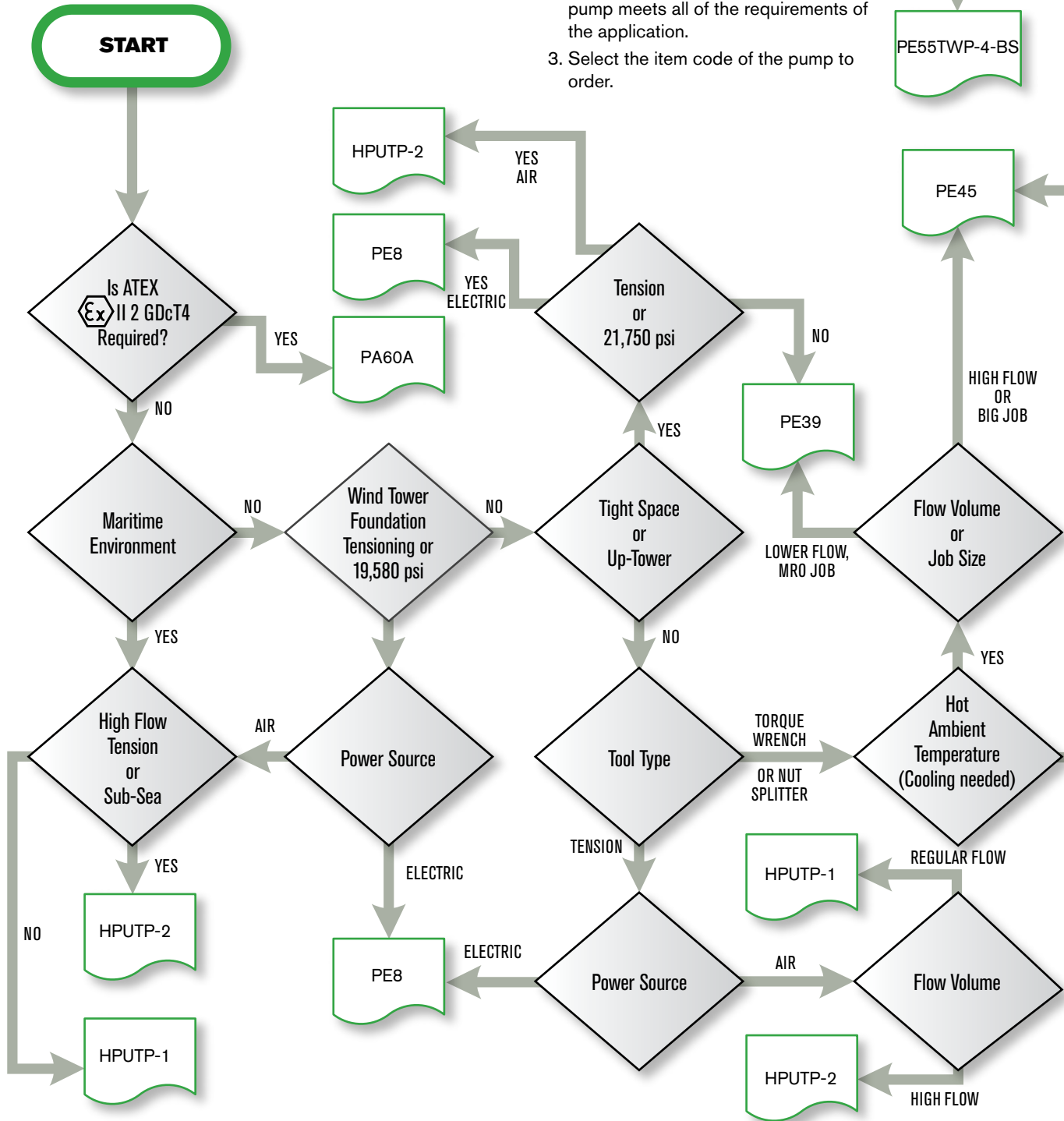

Due to the complexities involved in all of the hydraulic pump applications across the globe, this tool should be used as a guide only. After using this guide to find a pump family, a thorough review of the product should be completed to ensure suitability for a specific application and to find the proper item code. Additional product information can be found on sell sheets, in the catalog or on the web: www.spxboltingsystems.com Please contact the factory or an authorized reseller with questions.

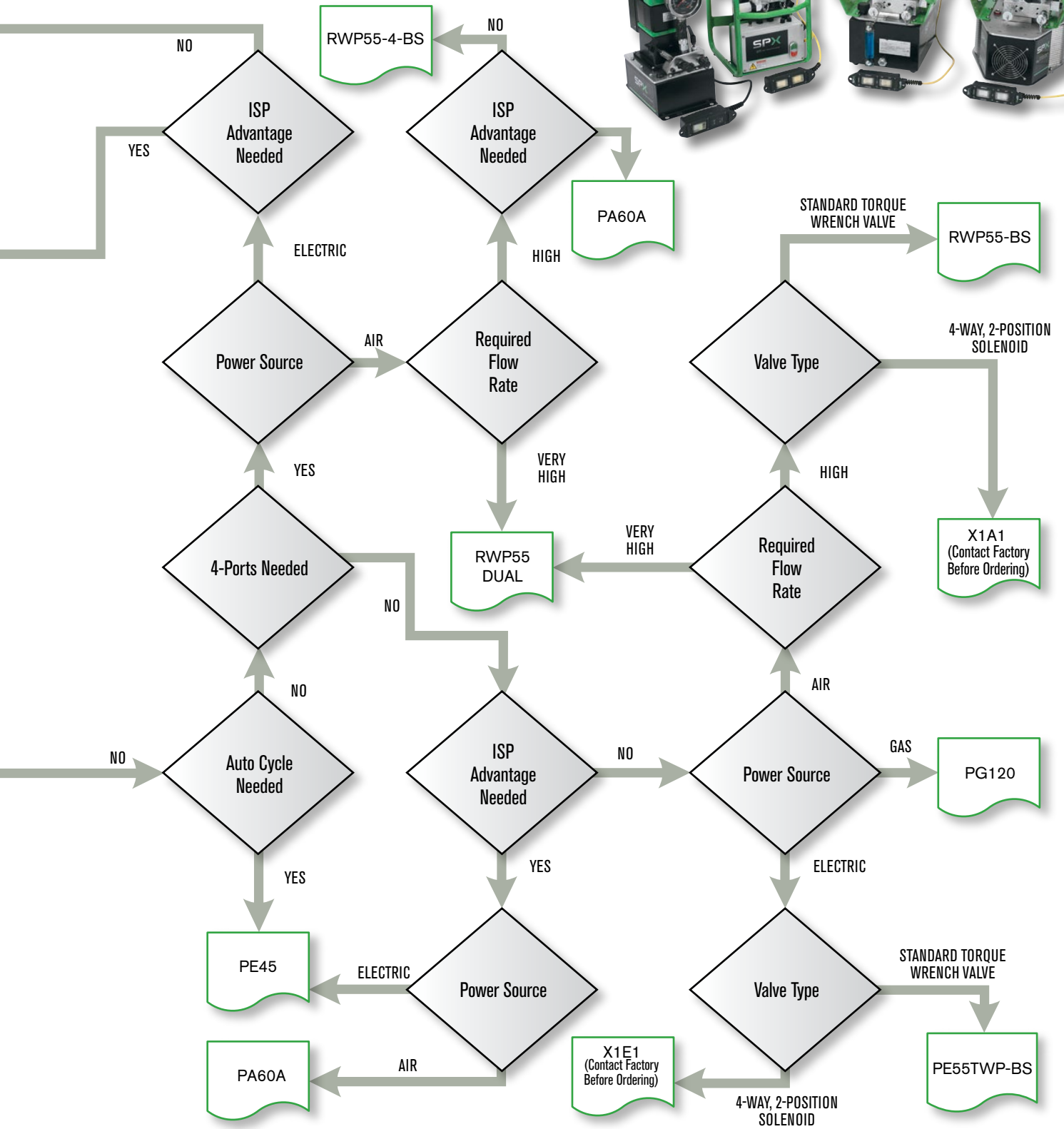





TORQUE WRENCHES

HIGH PERFORMANCE, BEST IN CLASS WRENCHES

Page
**MEASUREMENT/
SPECIFICATIONS... 11**
Torque Wrench Selection Guide

Page
**TORQUE WRENCH
OVERVIEW...12-13**



Page
TWHC... 14-15
High Cycle Torque Wrench



Page
TWSD...18-19
Square Drive Torque Wrench



Page
TWHC...16-17
Reaction Arms



Page
TWSD...20-21
Reactions Arms



Page
**ADAPTERS &
SOCKETS...22-23**



Page
TWLC...24-25
Drive Bodies



Page
TWLC...30
Reactions Arms

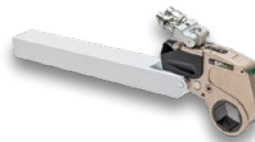

Page
TWL...26-29
Low Clearance Links



Page
TWLC...31
Custom Accessories



Page
TWR...28-29
Low Clearance Reducers

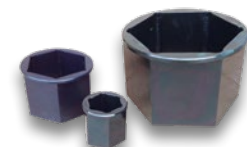

Page
TWSL...32-33
SlimLine

MEASUREMENTS/ SPECIFICATIONS

Torque Wrench Selection Guide



Specifications and Dimensional Data

Bolt Stud Size		Standard Hex Nut Size		Heavy Hex Nut Size		Break Out Tool			Make Up Tool		
in	mm	in	mm	in	mm	TWHC	TWSD	TWLC	TWHC	TWSD	TWLC
3/4	19	1-1/8	26	1-1/4	32	TWHC1	TWSD1	TWLC2	TWHC1	TWSD1	TWLC2
7/8	22	1-5/16	33	1-7/16	36	TWHC1	TWSD1	TWLC2	TWHC1	TWSD1	TWLC2
1	25	1-1/2	38	1-5/8	41	TWHC1	TWSD1	TWLC2	TWHC1	TWSD1	TWLC2
1-1/8	26	1-11/16	43	1-13/16	25	TWHC1	TWSD1	TWLC2	TWHC1	TWSD1	TWLC2
1-1/4	32	1-7/8	48	2	50	TWHC3	TWSD3*	TWLC4	TWHC1	TWSD1	TWLC2
1-3/8	35	2-1/16	52	2-3/16	55	TWHC6	TWSD6*	TWLC4	TWHC3	TWSD3*	TWLC4
1-1/2	38	2-1/4	57	2-3/8	60	TWHC6	TWSD6*	TWLC4	TWHC3	TWSD3*	TWLC4
1-5/8	41	2-7/16	62	2-9/16	65	TWHC6	TWSD6*	TWLC8	TWHC6	TWSD6*	TWLC4
1-3/4	44	2-5/8	67	2-3/4	70	TWHC6	TWSD6*	TWLC8	TWHC6	TWSD6*	TWLC4
1-7/8	48	2-13/16	71	2-15/16	75	-	TWSD11	TWLC8	TWHC6	TWSD6*	TWLC8
2	50	3	77	3-1/8	80	-	TWSD11	TWLC15	-	TWSD11	TWLC8
2-1/8	54	3-3/16	81	3-5/16	84	-	TWSD11	TWLC15	-	TWSD11	TWLC8
2-1/4	57	3-3/8	85	3-1/2	89	-	TWSD11	TWLC15	-	TWSD11	TWLC8
2-3/8	60	3-9/16	91	3-11/16	94	-	TWSD25	TWLC15	-	TWSD11	TWLC15
2-1/2	63	3-3/4	95	3-7/8	99	-	TWSD25	TWLC30	-	TWSD11	TWLC15
2-3/4	70	4-1/8	105	4-1/4	108	-	TWSD25	TWLC30	-	TWSD25	TWLC15
3	77	4-1/2	114	4 5/8	118	-	TWSD25	TWLC30	-	TWSD25	TWLC30
3-1/4	83	4-7/8	124	5	127	-	TWSD25	TWLC30	-	TWSD25	TWLC30
3-1/2	89	5-1/4	133	5 3/8	136	-	TWSD25	TWLC30	-	TWSD25	TWLC30
3-3/4	95	5-5/8		5-3/4	146	-	TWSD25	TWLC30	-	TWSD25	TWLC30
4	102	6	152	6 1/8	155	-	TWSD25	TWLC30	-	TWSD25	TWLC30
4-1/4	108			6-1/2	159	TWHC50	-		TWLC30 Upon Request	TWHC50	
4-1/2	114			6 7/8	175	TWHC50				TWHC50	
4-3/4	120			7-1/4	184	TWHC50				TWHC50	
5	127			7-5/8	193	TWHC50				TWHC50	
											TWLC30 Upon Request

Additional torque may be required for loosening in certain situations:

- Rust and corrosion: 2 X break out force
- Heat Corrosion: 3 X break out force

Only the smallest tool suitable for each application, under ideal conditions, is shown.

Tools shown are a guideline only. Chart is not a replacement for calculations. Lubrication, corrosion, material type will all effect actual torque requirement.

*TWSD1, TWSD3 and TWSD6 are obsolete and have been replaced by the TWHC Series.

TORQUE WRENCH OVERVIEW

TWLC

Patented rotating slide design adapts to angle against the piston, keeping forces normal in order to reduce wear and tear.

Unique slide and shuttle piston design automatically engages without the need to manually rotate tool.

Multi way swivel allows easier positioning of the hoses on the job site.

Pin is retained to the link body and will not fall out or get lost on the job site.

Improved hardened steel reaction pad to protect the tool during torquing and modified radius to fit tighter applications.

Steel body link with corrosion resistant nickel plating. Aluminum power head to reduce the overall weight of the tool.

Fully enclosed components without use of a shroud which can bend and cause safety issues.



TWHC

Multi-direction swivel allows operator to align the hoses in a convenient position, for any job!

Push button feature allows quick and easy release and re-positioning of the reaction arm without any tools.

Adaptable allen drive inserts for special applications, reference page 24.

With just a push of a button, the quick change square drive requires no tools to change from breakout to makeup.



TORQUE WRENCH

HIGH CYCLE - TWHC

Max Torque 71,816 Nm at 700 bar
(53,000 lb-ft at 10,000 psi)



NEW TECHNOLOGY

TORQUE WRENCH - HIGH CYCLE

Quality means Lower Cost of Ownership:

- Designed for high cycle life: 2-3x more than existing technology
- Increased reliability: Simple drive assembly means less downtime
- Corrosion resistant material for use in harsh environments

Enhanced Usability:

- Compact nose radius allows the tool to fit in tighter, hard-to-reach spaces
- Low weight, high strength design
- Fast operation, long stroke and optimum flow
- Multi-direction high flow swivel manifold
- Push button square drive reversal and reaction arm positioning
- Push-button release of square drive & reaction arm for all models except TWHC50.

Designed with Safety in Mind:

- Fully enclosed drive mechanism for operator safety
- Swivel manifold internal relief valve prevents retract side over-pressurization
- Fine tooth pawl prevents tool 'lock-on'

TWHC CONVERSION CHART, SEE PAGE 122

TW HANDLE



- Robust steel construction with ribbed polymer grip
- Multi-position on tool for balanced handling
- Cap-screw locking with positive 'docking'
- Is suitable for all wrench models (TWHC, TWSD, TWLC), however for larger sizes (TWSD25/TWLC 30/TWHC50) we recommend the use of eye-bolt lifting.

Order No.	Description	Tool Ref
DFTAS000001	Wrench Handle Size 1	TWSD1
		TWSD3
		TWHC1
		TWHC3
		TWLC2
DFTAS000002	Wrench Handle Size 2	TWSD6
		TWSD11
		TWHC6
		TWLC4
		TWLC8
		TWLC15

Specifications and Dimensional Data

TWHC

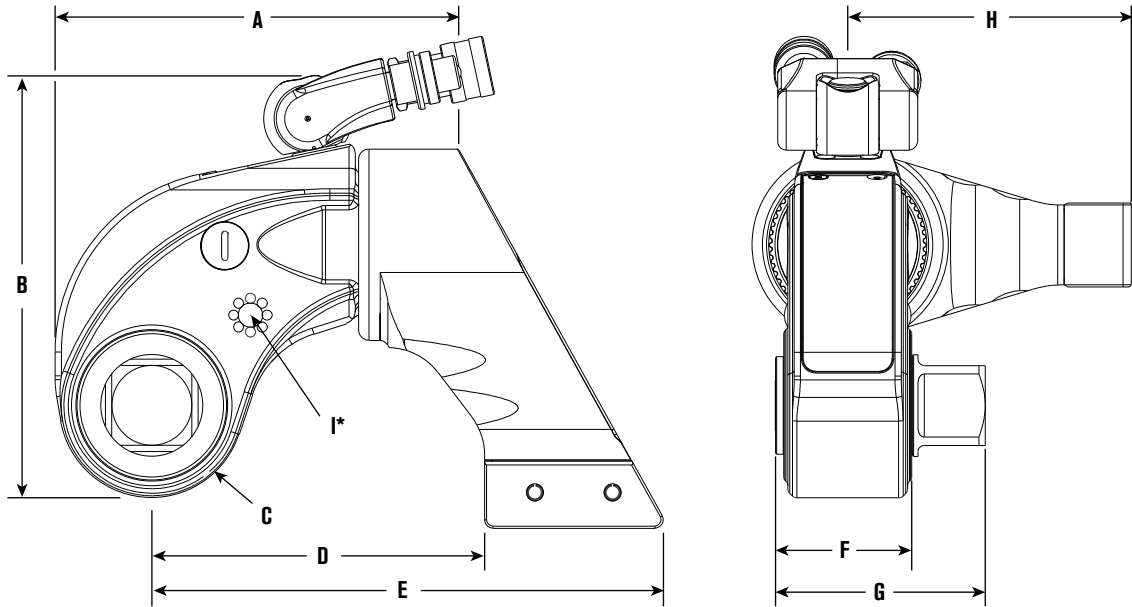

* Dimension I shows thread size (on both sides of the tool) for safety handle or lifting point. TWHC50 model available with lifting points only.

Tool Model	Min Torque		Max Torque		Square Drive	A	B	C	D	E	F	G	H	I	Weight	
	Nm	lb-ft	Nm	lb-ft											in	mm
TWHC1	230	170	1,915	1,413	3/4	132 (5.20)	145 (5.71)	28 (1.10)	111.5 (4.39)	170.0 (6.69)	39.5 (1.56)	67.7 (2.67)	86.1 (3.39)	M6 x 1.0	2.8	6.2
TWHC3	510	376	4,249	3,136	1	165 (6.50)	173.5 (6.83)	36.5 (1.44)	129.6 (5.10)	197.7 (7.78)	53 (2.09)	83.7 (3.30)	105.1 (4.14)	M6 x 1.0	5.3	11.7
TWHC6	984	726	8,198	6,050	1-1/2	192 (7.56)	201.6 (7.94)	44 (1.73)	158.5 (6.24)	243.7 (9.59)	61 (2.40)	99.9 (3.93)	135.1 (5.32)	M8 x 1.25	8.8	19.4
TWHC50	8,628	6,360	71,816	53,000	2-1/2	404.5 (15.93)	356.6 (14.04)	88 (3.46)	266.5 (10.49)	446.6 (17.58)	115 (4.53)	192.2 (7.57)	258 (10.16)	M12 x 1.75	69	152

Ordering Information

Order No.	Description	Order No.	Description	Order No.	Description
TWHC1	Wrench	TWHC1H	Wrench with handle	DFTAS000001	Handle for TWHC1
TWHC3	Wrench	TWHC3H	Wrench with handle	DFTAS000001	Handle for TWHC3
TWHC6	Wrench	TWHC6H	Wrench with handle	DFTAS000002	Handle for TWHC6
TWHC50	Wrench				

TORQUE WRENCH REACTIONS ARMS - TWHC

TWHC EXTENDED REACTION ARM TWHC-ERA



- Long reach version of TWHC standard reaction arm
- 3 standard sizes per model (+25mm/50mm/75mm) (+1 in / 2 in / 3 in), specials upon request
- Replaces standard reaction arm – quick release pin locking
- Steel alloy construction
- 360° rotation
- Available for full range of tool sizes

OK FOR SUBSEA



		Specifications and Dimensional Data									
Tool Ref	Order No.	L1		L2		L3		L4		Weight	
		mm	in	mm	in	mm	in	mm	in	kg	lb
TWHC1	TWHC1-ERA1	137	5.39	111	4.37	60	2.36	30	1.18	2	4.4
	TWHC1-ERA2	162	6.38	136	5.35					2.3	5.1
	TWHC1-ERA3	187	7.36	161	6.34					2.6	5.7
TWHC3	TWHC3-ERA1	155	6.10	130	5.12	70	2.76	35	1.38	3	6.6
	TWHC3-ERA2	180	7.09	155	6.10					3.5	7.7
	TWHC3-ERA3	205	8.07	180	7.09					3.9	8.6
TWHC6	TWHC6-ERA1	184	7.24	161	6.34	95	3.74	40	1.57	5	11
	TWHC6-ERA2	209	8.23	186	7.32					5.6	12.4
	TWHC6-ERA3	234	9.21	211	8.31					6.2	13.7



HANDLES SOLD SEPARATELY

The tool's designed long-stroke mechanism imparts a minimum 30 degree nut rotation per stroke while maintaining a tight and compact nose radius: this is a clear advantage over the short stroke and back-up pawl mechanisms of light alloy competitive models. Fewer parts and reduced torsion in operation - equals reduced wear, maintenance and associated costs.

Specifications and Dimensional Data

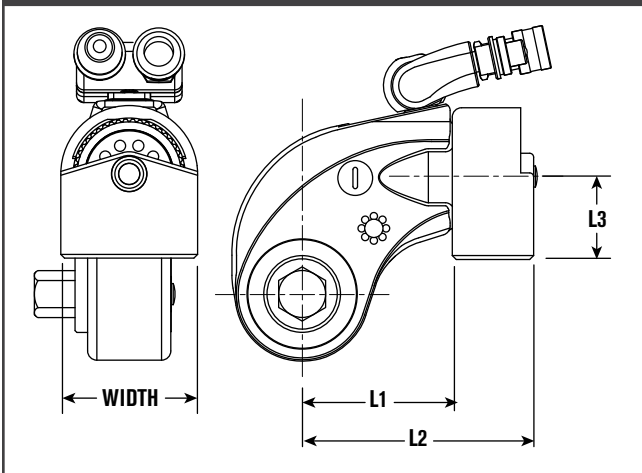

Tool Ref	Order No.	L1		L2		L3		Width		Weight	
		mm	in	mm	in	mm	in	mm	in	kg	lb
TWHC1	TWHC1-RP	72	2.835	116	4.567	49	1.93	64	2.52	1	2.2
TWHC3	TWHC3-RP	86	3.39	138	5.43	55	2.17	76	2.99	1.5	3.3
TWHC6	TWHC6-RP	99	3.90	162	6.38	62	2.44	89	3.50	2.3	5.1

TWHC REACTION PAD TWHC-RP



- Wrench In-Line Reaction Pad for TWHC wrench: used as simple pad or modified platform for specific application (Machine-able/Weld-able platform)
- Replaces standard reaction arm – quick release pin locking
- Steel alloy construction
- 360 degree rotation
- Available for full range of tool sizes

Specifications and Dimensional Data

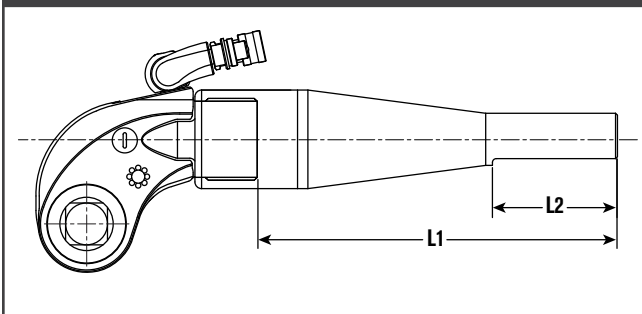

Tool Ref	Order No.	L1		L2		Weight	
		mm	in	mm	in	kg	lb
TWHC1	TWHC1-LRA	501	19.72	152	6	4.5	9.9
TWHC3	TWHC3-LRA					6	13.2
TWHC6	TWHC6-LRA					8.1	17.9

TWHC LONG REACTION ARM TWHC-LRA



- Tubular extension arm for TWHC wrench: in-line reaction outside wrench profile
- Replaces standard reaction arm – quick release pin locking
- Steel/light alloy construction (reaction flat machined on tube end)
- Can be cut down to suit specific length
- Available for full range of tool sizes

TORQUE WRENCH

SQUARE DRIVE - TWSD

Max Torque 33,198 Nm at 700 bar
(24,500 lb-ft at 10,000 psi)



360° Reaction Arm

OK FOR SUBSEA



SQUARE DRIVE TORQUE WRENCH

- Low weight, high strength design
- Superior torsional strength
- Fast operation cycle
- Fine tooth ratchet
- Floating piston design
- Swivel manifold internal relief valve prevents retract side over-pressurization
- Rigid steel body construction
- Compact frame size
- Reaction and drive accessories available

**TWSD CONVERSION CHART,
SEE PAGE 120**



Specifications and Dimensional Data

- Push button reversal of square drive
- Corrosion resistant finish
- 360° reaction arm
- Push to lock reaction arms
- Multi-axis high flow swivel manifold
- Simple design
- Consistently accurate torque output
- Fully enclosed drive mechanism

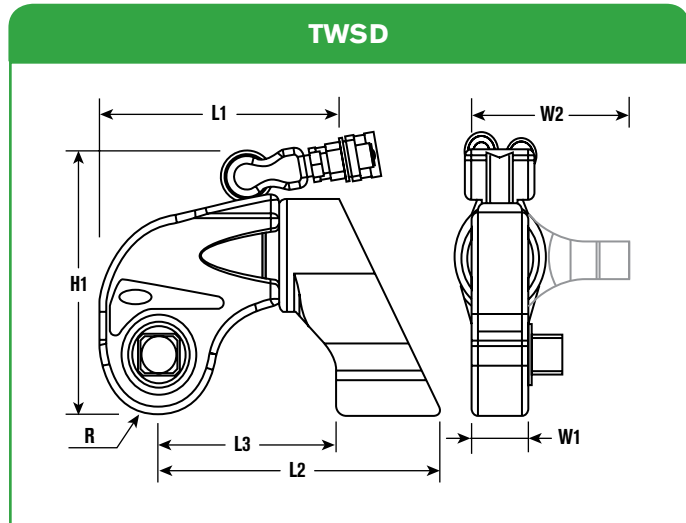

Tool Model	L1		L2		L3		H1		R		W1		W2	
	mm	in	mm	in	mm	in	mm	in	mm	in	mm	in	mm	in
TWSD11	234	9.2	292	11.5	178	7.0	241	9.5	56	2.2	61	2.4	165	6.5
TWSD25	305	12	376	14.8	231	9.1	315	12.4	71	2.8	76	3.0	200	7.9

Tool Model	Square Drive in	Min Torque		Max. Torque		Tool Weight	
		Nm	lb-ft	Nm	lb-ft	kg	lb
TWSD11	1-1/2	1,780	1,313	14,823	10,940	13.1	28.9
TWSD25	2-1/2	3,984	2,940	33,198	24,500	29.5	65.0

Ordering Information

Order No.	Description	Order No.	Description
TWSD11	WRENCH - 14,823 Nm , 10,940 lb-ft	DFTAS000002	WRENCH HANDLE Size 2
TWSD25	WRENCH - 33,198 Nm , 24,500 lb-ft		Tool Ref. TWSD11

Standard Reaction Arm included for all models

TORQUE WRENCH REACTION ARMS - TWSD

TWSD EXTENDED REACTION ARM TWSD-ERA



- Long reach version of TWSD standard reaction arm
- 3 standard sizes per model (+25mm/50mm/75mm) (+1 in / 2 in / 3 in), specials upon request
- Replaces standard reaction arm – quick release pin locking
- Steel alloy construction
- 360° rotation
- Available for full range of tool sizes

Specifications and Dimensional Data

Tool Ref	Order No.	L1		L2		L3		L4		Weight	
		mm	in	mm	in	mm	in	mm	in	kg	lb
TWSD11	TWSD11-ERA1	204	8.03	190	7.48					8	17.6
	TWSD11-ERA2	229	9.02	215	8.46	110	4.33	40	1.57	8.5	18.7
	TWSD11-ERA3	254	10	240	9.45					9.5	20.9
TWSD25	TWSD25-ERA1	256	10.08	225	8.86	145				18	39.7
	TWSD25-ERA2	281	11.06	250	9.84		5.71	50	1.97	20	44.1
	TWSD25-ERA3	306	12.05	275	10.83	147				21	46.3



Torque Wrench Handle



SEE PAGE 14

Specifications and Dimensional Data

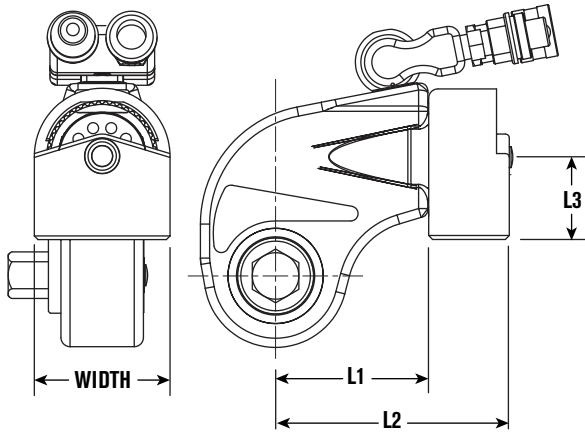

Tool Ref	Order No.	L1		L2		L3		Width		Weight	
		mm	in	mm	in	mm	in	mm	in	kg	lb
TWSD11	TWSD11-RP	109,5	4.311	184,5	7.264	65,5	2.579	105	4.133	4	8.8
TWSD25	TWSD25-RP	136,5	5.374	243,5	9.587	88,5	3.484	143	5.630	10	22

TWSD REACTION PAD TWSD-RP



- Wrench In-Line Reaction Pad for TWSD wrench: used as simple pad or modified platform for specific application (Machine-able/Weld-able platform)
- Replaces standard reaction arm – quick release pin locking
- Steel alloy construction
- 360 degree rotation
- Available for full range of tool sizes

Specifications and Dimensional Data

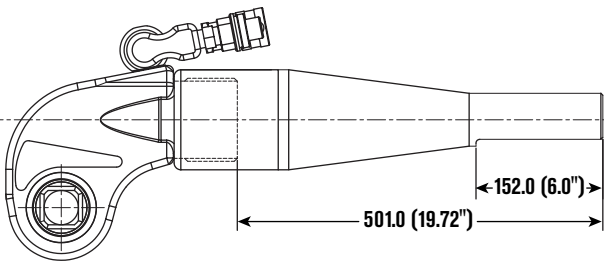

Tool Ref	Order No.	L1		L2		Weight	
		mm	in	mm	in	kg	lb
TWSD11	TWSD11-LRA	501	19.72	152	6	11	24.3
TWSD25	TWSD25-LRA					22	48.5

TWSD LONG REACTION ARM TWSD-LRA



- Tubular extension arm for TWSD wrench: in-line reaction outside wrench profile
- Replaces standard reaction arm – quick release pin locking
- Steel/light alloy construction (reaction flat machined on tube end)
- Can be cut down to suit specific length
- Available for full range of tool sizes

SQUARE DRIVE ADAPTERS & SOCKETS

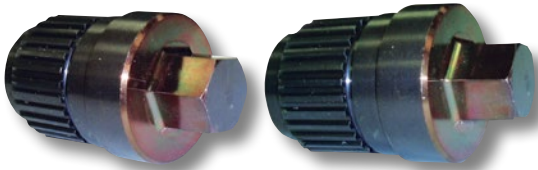

Customs sizes are available upon request

Male Hex Drive

Wrench Size	Hexagon Drive Size A/F (inch)	Order No.		Hexagon Drive Size A/F (mm)	Order No.	
		TWSD	TWHC		TWSD	TWHC
1 (TWHC1)	5/8		TWHCHD01-063	17mm		TWHCHD01-017
	3/4		TWHCHD01-075	19mm		TWHCHD01-019
	7/8		TWHCHD01-088	22mm		TWHCHD01-022
	1		TWHCHD01-100	24mm		TWHCHD01-024
				27mm		TWHCHD01-027
3 (TWHC3)	5/8		TWHCHD03-063	17mm		TWHCHD03-017
	3/4		TWHCHD03-075	19mm		TWHCHD03-019
	7/8		TWHCHD03-088	22mm		TWHCHD03-022
	1		TWHCHD03-100	24mm		TWHCHD03-024
	1-1/8		TWHCHD03-113	27mm		TWHCHD03-027
	1-1/4		TWHCHD03-125	30mm		TWHCHD03-030
	1-3/8		TWHCHD03-138	32mm		TWHCHD03-032
	1-1/2		TWHCHD03-150	36mm		TWHCHD03-036
1-5/8		TWHCHD03-163	41mm		TWHCHD03-041	
6 (TWHC6)	5/8		TWHCHD06-063	17mm		TWHCHD06-017
	3/4		TWHCHD06-075	19mm		TWHCHD06-019
	7/8		TWHCHD06-088	22mm		TWHCHD06-022
	1		TWHCHD06-100	24mm		TWHCHD06-024
	1-1/8		TWHCHD06-113	27mm		TWHCHD06-027
	1-1/4		TWHCHD06-125	30mm		TWHCHD06-030
	1-3/8		TWHCHD06-138	32mm		TWHCHD06-032
	1-1/2		TWHCHD06-150	36mm		TWHCHD06-036
1-5/8		TWHCHD06-163	41mm		TWHCHD06-041	
11 (TWSD11)	1-1/8	TWD11-113		27mm	TWD11-027	
	1-1/4	TWD11-125		30mm	TWD11-030	
	1-3/8	TWD11-138		32mm	TWD11-032	
	1-1/2	TWD11-150		36mm	TWD11-036	
	1-5/8	TWD11-163		41mm	TWD11-041	
	1-3/4	TWD11-175		46mm	TWD11-046	
25 (TWSD25)	1-1/2	TWD25-150		36mm	TWD25-036	
	1-5/8	TWD25-163		41mm	TWD25-041	
	1-3/4	TWD25-175		46mm	TWD25-046	
	1-7/8	TWD25-188		50mm	TWD25-050	
	2	TWD25-200		55mm	TWD25-055	
	2-1/4	TWD25-225		60mm	TWD25-060	
	2-1/2	TWD25-250		65mm	TWD25-065	
2-3/4	TWD25-275		70mm	TWD25-070		



Impact Sockets - Imperial (for TWHC & TWSD)

Socket Size Imperial	3/4" Drive Order No.	1" Drive Order No.	1-1/2" Drive Order No.	2-1/2" Drive Order No.
7/8"	TWSIA088	TWSIB088	-	-
1-1/16"	TWSIA106	TWSIB106	-	-
1-1/4"	TWSIA125	TWSIB125	-	-
1-3/8"	TWSIA138	TWSIB138	-	-
1-7/16"	TWSIA144	TWSIB144	-	-
1-5/8"	TWSIA163	TWSIB163	TWSC163	-
1-13/16"	TWSIA181	TWSIB181	-	-
2"	TWSIA200	TWSIB200	TWSC200	-
2-3/16"	TWSIA219	TWSIB219	TWSC219	-
2-3/8"	TWSIA238	TWSIB238	TWSC238	-
2-9/16"	-	TWSIB256	TWSC256	-
2-3/4"	-	TWSIB275	TWSC275	-
2-15/16"	-	TWSIB294	TWSC294	-
3-1/8"	-	TWSIB313	TWSC313	TWSIF313
3-3/8"	-	TWSIB338	TWSC338	TWSIF338
3-12"	-	TWSIB350	TWSC350	TWSIF350
3-3/4"	-	TWSIB375	TWSC375	TWSIF375
3-7/8"	-	TWSIB388	-	TWSIF388
4-1/8"	-	TWSIB413	TWSC413	TWSIF413
4-1/4"	-	TWSIB425	TWSC425	TWSIF425
4-5/8"	-	-	TWSC463	TWSIF463
5"	-	-	-	TWSIF500
5-3/8"	-	-	-	TWSIF538
5-3/4"	-	-	-	TWSIF575
6-1/8"	-	-	-	TWSIF613

Impact Sockets - Metric (for TWHC & TWSD)

Socket Size Metric	3/4" Drive Order No.	1" Drive Order No.	1-1/2" Drive Order No.	2-1/2" Drive Order No.
22mm	TWSMA022	TWSMB022	-	-
24mm	TWSMA024	TWSMB024	-	-
32mm	TWSMA032	TWSMB032	-	-
36mm	TWSMA036	TWSMB036	-	-
41mm	TWSMA041	TWSMB041	TWSMC041	-
46mm	TWSMA046	TWSMB046	-	-
50mm	TWSMA050	TWSMB050	-	-
55mm	-	TWSMB055	-	-
60mm	-	TWSMB060	TWSMC060	-
65mm	-	TWSMB065	TWSMC065	-
70mm	-	TWSMB070	TWSMC070	-
75mm	-	-	TWSMC075	-
80mm	-	TWSMB080	TWSMC080	TWSMF080
85mm	-	TWSMB085	TWSMC085	TWSMF085
90mm	-	TWSMB090	TWSMC090	TWSMF090
95mm	-	TWSMB095	TWSMC095	TWSMF095
100mm	-	TWSMB100	-	TWSMF100
110mm	-	TWSMB110	TWSMC110	TWSMF110
115mm	-	-	TWSMC115	TWSMF115
120mm	-	-	TWSMC120	-
135mm	-	-	-	TWSMF135
150mm	-	-	-	TWSMF150

For Long Reach (Extended Length) sockets add "LR" to the end of the part number. For 12 point (bi-hex) sockets, add "BH" to the end of the part number.

TORQUE WRENCH

LOW CLEARANCE - TWLC

Max Torque 39,024 Nm at 700 bar
(28,800 lb-ft at 10,000 psi)



TORQUE WRENCH LOW CLEARANCE

The TWLC Series Wrench was designed for the most inaccessible bolting areas found in the industry. Its long neck, short height and small radius have all added to its great success.



Several link sizes are available for each drive.

Combine a drive body with a link to make a wrench. Each are sold separately.

**TWSD CONVERSION CHART,
SEE PAGE 121**

OK FOR SUBSEA



Torque Wrench Handle



SEE PAGE 14

Specifications and Dimensional Data

- Low weight, high strength design
- Superior torsional strength
- Fast operation cycle
- Fine tooth ratchet
- Floating piston design
- Link pin does not fall out
- Auto-connect drive piston
- Compact frame size
- Rigid steel body construction
- Swivel manifold internal relief valve prevents retract side over-pressurization
- “Hardened” steel reaction pad on TWLC8, 15 & 30
- Small nose radius
- Corrosion resistant finish
- Multi-axis high flow swivel manifold
- Simple design
- Consistent torque output

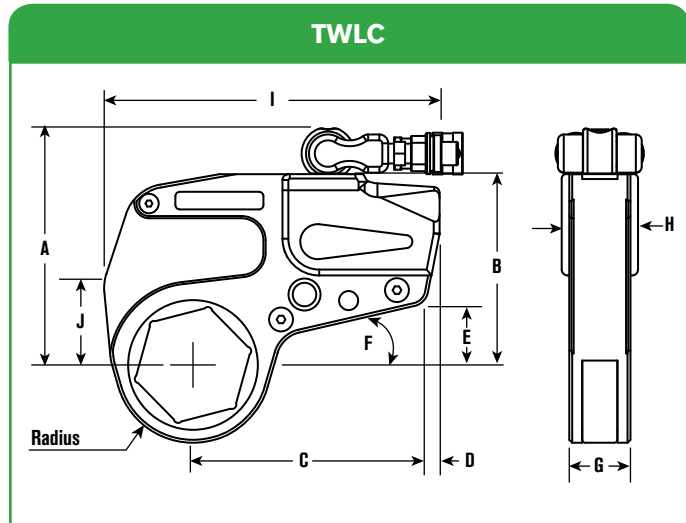

- Quick interchangeable heads, no tools necessary
- Replaceable reaction pad on larger models

Body Order No.	A		B		C		D		E		F	G		H	
	mm	in	mm	in	mm	in	mm	in	mm	in	deg	mm	in	mm	in
TWLC2	136	5.4	103	4.1	128	5	8	0.3	35	1.4	13	32	1.3	42	1.7
TWLC4	163	6.4	130	5.1	159	6.3	9	0.4	43	1.7	13	42	1.7	52	2
TWLC8	195	7.7	158	6.2	177	7	24.5	1	40	1.6	14	54	2.1	67	2.6
TWLC15	223	8.8	186	7.3	200	7.9	27	1.1	43	1.7	14	63	2.5	76	3
TWLC30	276	10.9	239	9.4	267	10.5	26	1	62	2.4	15	82	3.2	94	3.7

Body Order No.	Hex Range				Min Torque		Max Torque		Weight (Body Only)	
	mm	mm	in	in	Nm	lb-ft	Nm	lb-ft	kg	lb
TWLC2	26	60	1	2-3/8	256	189	2,134	1,575	1.0	2.2
TWLC4	33	80	1-5/16	3-1/8	646	477	5,386	3,975	2.0	4.4
TWLC8	49	100	1-7/8	3-15/16	1,293	954	10,772	7,950	3.5	7.7
TWLC15	62	116	2-7/16	4-5/8	2,415	1,782	20,122	14,850	7.0	15.4
TWLC30	80	155	3-1/8	6-1/16	4,683	3,456	39,024	28,800	14.5	31.9

CAUTION: Always read operating manual before using for proper use of tools and accessories.

NOTE: Reference dimensions shown and vary by links size. Exact dimensions can be found on our website.

Ordering Information

TO SPECIFY A TWLC SOLUTION:

1. Find a link for your application (nut size) (page 25-27)
2. Choose the appropriate Drive body (page 23)
3. Add reducers for additional nut sizes (pages 26-29)

Please order Drive Body and Link separately and pay attention to the same size, for Example TWLC2 and TWL2-041.

TORQUE WRENCH

LOW CLEARANCE LINKS - TWLC

Parts Codes, Nose Radius

NOTE:

The sizes listed on these pages encompass both heavy hex and standard hex nut sizes. Check your local SPX FLOW Bolting Office for availability as some items may be special order.

Nut A/F		Link Order No.	TWLC2				TWLC4					TWLC8								
Inch	Metric		Radius R	I	J	Weight (Link Only)	Link Order No.	Radius R	I	J	Weight (Link Only)	Link Order No.	Radius R	I	J	Weight (Link Only)				
			mm (in)	mm (in)	mm (in)	kg (lb)		mm (in)	mm (in)	mm (in)	kg (lb)		mm (in)	mm (in)	mm (in)	kg (lb)				
1	26	TWL2-026																		
1-1/16	27	TWL2-027																		
1-1/8	29	TWL2-029																		
1-3/16	30	TWL2-030	31.5 (1.2)	180 (7.1)	38 (1.5)	2 (4.4)														
1-1/4	32	TWL2-032																		
1-5/16	33	TWL2-033																		
1-3/8	35	TWL2-035																		
1-7/16	36	TWL2-036																		
1-1/2	38	TWL2-150																		
1-9/16	40	TWL2-040	34.5 (1.4)	181 (7.1)	40 (1.6)	2 (4.4)														
1-5/8	41	TWL2-041																		
1-11/16	43	TWL2-043																		
1-3/4	44	TWL2-044	37 (1.5)	183 (7.2)	40 (1.6)	2 (4.4)														
1-13/16	46	TWL2-046																		
1-7/8	48	TWL2-188																		
1-15/16	49	TWL2-049	40 (1.6)	185 (7.3)	43 (1.7)	2 (4.4)														
2	50	TWL2-050																		
2-1/16	52	TWL2-052																		
2-1/8	54	TWL2-054	42.5 (1.7)	185 (7.3)	43 (1.7)	2 (4.4)														
2-3/16	55	TWL2-055																		
2-1/4	57	TWL2-057																		
2-5/16	59	TWL2-059																		
2-3/8	60	TWL2-060	45.5 (1.8)	185 (7.3)	43 (1.7)	2 (4.4)														
2-7/16	62																			
2-1/2	63																			
2-9/16	65																			
2-5/8	67																			
2-11/16	68																			
2-3/4	70																			
2-13/16	71																			
2-7/8	73																			
2-15/16	75																			
3	77																			
3-1/16	78																			
3-1/8	80																			
3-3/16	81																			
3-1/4	83																			
3-5/16	84																			
3-3/8	85																			
3-7/16	87																			
	89																			
3-1/2	90																			
3-9/16	91																			
3-5/8	92																			
3-11/16	94																			
3-3/4	95																			
3-13/16	97																			
	99																			
3-7/8	100																			

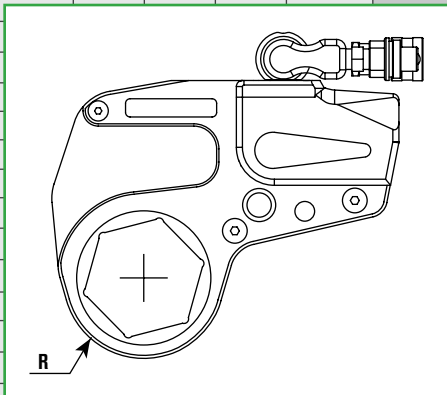

MORE SOLUTIONS ON NEXT PAGE

Ordering Information

TO SPECIFY A TWLC SOLUTION:

1. Find a link for your application (nut size) (page 26-27)
2. Choose the appropriate Drive body (page 23)
3. Add reducers for additional nut sizes (pages 28-29)

Please order Drive Body and Link separately and pay attention to the same size, for Example TWLC2 and TWL2-041.

Nut A/F		Link Order No.	TWLC15				Link Order No.	TWLC30				Link Order No.	Nut A/F		Link Order No.	TWLC30 (Continued)											
Inch	Metric		Radius R mm (in)	I mm (in)	J mm (in)	Weight (Link Only) kg (lb)		Radius R mm (in)	I mm (in)	J mm (in)	Weight (Link Only) kg (lb)		Inch	Metric		Radius R mm (in)	I mm (in)	J mm (in)	Weight (Link Only) kg (lb)								
2-7/16	62	TWL15-062										4-13/16	122	TWL30-122													
2-1/2	63	TWL15-063											123	TWL30-123													
2-9/16	65	TWL15-065	60.5 (2.4)	313 (12.3)	88 (3.5)	12.5 (27.5)						4-7/8	124	TWL30-124	99 (3.9)	400 (15.7)	109 (4.3)	28.5 (62.7)									
2-5/8	67	TWL15-067																	4-15/16	125	TWL30-125						
2-11/16	68	TWL15-068																	5	127	TWL30-500						
2-3/4	70	TWL15-070																	5-1/16	129	TWL30-129						
2-13/16	71	TWL15-071																	5-1/8	130	TWL30-130						
2-7/8	73	TWL15-073	63 (2.5)	313 (12.3)	88 (3.5)	12.5 (27.5)						5-3/16	132	TWL30-132	105 (4.1)	400 (15.7)	109 (4.3)	28.5 (62.7)									
2-15/16	75	TWL15-075																	5-1/4	133	TWL30-133						
3	77	TWL15-077																	5-3/8	135	TWL30-135						
3-1/16	78	TWL15-313					66.5 (2.6)	313 (12.3)	88 (3.5)	13 (28.6)											137	TWL30-538					
3-1/8	80	TWL15-080																						5-7/16	138	TWL30-138	
3-3/16	81	TWL15-081															5-1/2	140	TWL30-140								
3-1/4	83	TWL15-083															5-9/16	141	TWL30-141	110 (4.3)	400 (15.7)	109 (4.3)	28.5 (62.7)				
3-5/16	84	TWL15-084															5-5/8	143	TWL30-143								
3-3/8	85	TWL15-085	72 (2.8)	313 (12.3)	80 (3.1)	13.5 (29.7)								5-11/16	144	TWL30-144											
3-7/16	87	TWL15-087															5-3/4	145	TWL30-145								
	89	TWL15-089																146	TWL30-146								
3-1/2	90	TWL15-090																5-13/16	148	TWL30-148							
3-9/16	91	TWL15-091																5-7/8	149	TWL30-149							
3-5/8	92	TWL15-092													150	TWL30-150											
3-11/16	94	TWL15-094	78 (3.1)	316 (12.4)	80 (3.1)	13.5 (29.7)									5-15/16	151	TWL30-151	116 (4.6)	400 (15.7)	109 (4.3)	29.5 (64.9)						
3-3/4	95	TWL15-095															6					152	TWL30-152				
3-13/16	97	TWL15-097																				6-1/16	154	TWL30-154			
	99	TWL15-388																				6-1/8	155	TWL30-155			
3-7/8	100	TWL15-100																									
4	102	TWL15-102																									
4-1/16	103	TWL15-103	82.5 (3.2)	316 (12.4)	80 (3.1)	14 (30.8)																					
4-1/8	105	TWL15-105																									
4-3/16	106	TWL15-106																									
4-1/4	108	TWL15-425																									
4-5/16	110	TWL15-110																									
4-3/8	111	TWL15-111	87.5 (3.4)	316 (12.4)	80 (3.1)	14 (30.8)																					
4-7/16	113	TWL15-113																									
4-1/2	114	TWL15-114																									
	115	TWL15-115																									
4-9/16	116	TWL15-116																									
4-5/8	117	TWL15-463																									
4-11/16	119																										
4-3/4	120																										

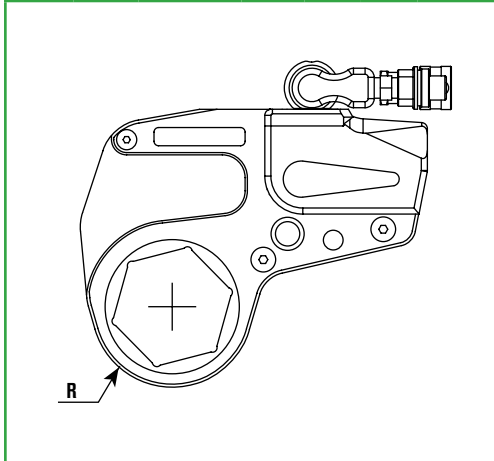

MORE SOLUTIONS ON NEXT PAGE

12 point links available upon request. Please contact factory.

TORQUE WRENCH

LOW CLEARANCE REDUCERS - TWLC

Drive Body, Links & Reducers

Special sizes available upon request.



Specifications and Dimensional Data

Body Order No.	Reference Link No.	Nut A/F		Reducer		Reducer		Reducer		Reducer		Order No.
		mm	in	mm	in	mm	in	mm	in	mm	in	
TWLC2	TWL2-032	32	1-1/4	-	-	-	-	-	-	-	-	-
	TWL2-036	36	1-7/16	-	-	-	-	-	-	-	-	-
	TWL2-041	41	1-5/8	41-36	1-5/8 - 1-7/16	TWR2-041036	41-32	1-5/8 - 1-1/4	TWR2-041032	-	-	-
	TWL2-046	46	1-13/16	46-41	1-13/16 - 1-5/8	TWR2-046041	46-36	1-13/16 - 1-7/16	TWR2-046036	46-32	1-13/16 - 1-1/4	TWR2-046032
	TWL2-050	50	2	50-46	2 - 1-13/16	TWR2-050046	50-41	2 - 1-5/8	TWR2-050041	50-36	2 - 1-7/16	TWR2-050036
	TWL2-055	55	2-3/16	55-50	2-3/16 - 2	TWR2-055050	55-46	2-3/16 - 1-13/16	TWR2-055046	55-41	2-3/16 - 1-5/8	TWR2-055041
	TWL2-060	60	2-3/8	60-55	2-3/8 - 2-3/16	TWR2-060055	60-50	2-3/8 - 2	TWR2-060050	60-46	2-3/8 - 1-13/16	TWR2-060046
TWLC4	TWL4-041	41	1-5/8	41-36	1-5/8 - 1-7/16	TWR4-041036	41-32	1-5/8 - 1-1/4	TWR4-041032	-	-	-
	TWL4-046	46	1-13/16	46-41	1-13/16 - 1-5/8	TWR4-046041	46-36	1-13/16 - 1-7/16	TWR4-046036	46-32	1-13/16 - 1-1/4	TWR4-046032
	TWL4-050	50	2	50-46	2 - 1-13/16	TWR4-050046	50-41	2 - 1-5/8	TWR4-050041	50-36	2 - 1-7/16	TWR4-050036
	TWL4-055	55	2-3/16	55-50	2-3/16 - 2	TWR4-055050	55-46	2-3/16 - 1-13/16	TWR4-055046	55-41	2-3/16 - 1-5/8	TWR4-055041
	TWL4-060	60	2-3/8	60-55	2-3/8 - 2-3/16	TWR4-060055	60-50	2-3/8 - 2	TWR4-060050	60-46	2-3/8 - 1-13/16	TWR4-060046
	TWL4-065	65	2-9/16	65-60	2-9/16 - 2-3/8	TWR4-065060	65-55	2-9/16 - 2-3/16	TWR4-065055	65-50	2-9/16 - 2	TWR4-065050
	TWL4-070	70	2-3/4	70-65	2-3/4 - 2-9/16	TWR4-070065	70-60	2-3/4 - 2-3/8	TWR4-070060	70-55	2-3/4 - 2-3/16	TWR4-070055
	TWL4-075	75	2-15/16	75-70	2-15/16 - 2-3/4	TWR4-075070	75-65	2-15/16 - 2-9/16	TWR4-075065	75-60	2-15/16 - 2-3/8	TWR4-075060
	TWL4-080	80	3-1/8	80-75	3-1/8 - 2-15/16	TWR4-080075	80-70	3-1/8 - 2-3/4	TWR4-080070	80-65	3-1/8 - 2-9/16	TWR4-080065
TWLC8	TWL8-060	60	2-3/8	60-55	2-3/8 - 2-3/16	TWR8-060055	60-50	2-3/8 - 2	TWR8-060050	60-46	2-3/8 - 1-13/16	TWR8-060046
	TWL8-065	65	2-9/16	65-60	2-9/16 - 2-3/8	TWR8-065060	65-55	2-9/16 - 2-3/16	TWR8-065055	65-50	2-9/16 - 2	TWR8-065050
	TWL8-070	70	2-3/4	70-65	2-3/4 - 2-9/16	TWR8-070065	70-60	2-3/4 - 2-3/8	TWR8-070060	70-55	2-3/4 - 2-3/16	TWR8-070055
	TWL8-075	75	2-15/16	75-70	2-15/16 - 2-3/4	TWR8-075070	75-65	2-15/16 - 2-9/16	TWR8-075065	75-60	2-15/16 - 2-3/8	TWR8-075060
	TWL8-080	80	3-1/8	80-75	3-1/8 - 2-15/16	TWR8-080075	80-70	3-1/8 - 2-3/4	TWR8-080070	80-65	3-1/8 - 2-9/16	TWR8-080065
	TWL8-085	85	3-3/8	85-80	3-3/8 - 3-1/8	TWR8-085080	85-65	3-3/8 - 2-15/16	TWR8-085065	85-70	3-3/8 - 2-3/4	TWR8-085070
	TWL8-090	90	3-1/2	90-85	3-1/2 - 3-3/8	TWR8-090085	90-80	3-1/2 - 3-1/8	TWR8-090080	90-75	3-1/2 - 2-15/16	TWR8-090075
	TWL8-095	95	3-3/4	95-90	3-3/4 - 3-1/2	TWR8-095090	95-85	3-3/4 - 3-3/8	TWR8-095085	95-80	3-3/4 - 3-1/8	TWR8-095080
	TWL8-100	100	3-7/8	100-95	3-7/8 - 3-3/4	TWR8-100095	100-90	3-7/8 - 3-1/2	TWR8-100090	100-85	3-7/8 - 3-3/8	TWR8-100085

Ordering Information

TO SPECIFY A TWLC SOLUTION:

1. Find a link for your application (nut size) (page 24-27)
2. Choose the appropriate Drive body (page 23)
3. Add reducers for additional nut sizes (pages 26-29)

Please order Drive Body and Link separately and pay attention to the same size, for Example TWLC2 and TWL2-041.



Specifications and Dimensional Data

Body Order No.	Reference Link No.	Nut A/F		Reducer			Reducer			Reducer		
		mm	in	mm	in	Order No.	mm	in	Order No.	mm	in	Order No.
TWLC15	TWL15-070	70	2-3/4	70-65	2-3/4 - 2-9/16	TWR15-070065	70-60	2-3/4 - 2-3/8	TWR15-070060	70-55	2-3/4 - 2-3/16	TWR15-070055
	TWL15-075	75	2-15/16	75-70	2-15/16 - 2-3/4	TWR15-075070	75-65	2-15/16 - 2-9/16	TWR15-075065	75-60	2-15/16 - 2-3/8	TWR15-075060
	TWL15-080	80	3-1/8	80-75	3-1/8 - 2-15/16	TWR15-080075	80-70	3-1/8 - 2-3/4	TWR15-080070	80-65	3-1/8 - 2-9/16	TWR15-080065
	TWL15-085	85	3-3/8	85-80	3-3/8 - 3-1/8	TWR15-085080	85-65	3-3/8 - 2-15/16	TWR15-085065	85-70	3-3/8 - 2-3/4	TWR15-085070
	TWL15-090	90	3-1/2	90-85	3-1/2 - 3-3/8	TWR15-090085	90-80	3-1/2 - 3-1/8	TWR15-090080	90-75	3-1/2 - 2-15/16	TWR15-090075
	TWL15-095	95	3-3/4	95-90	3-3/4 - 3-1/2	TWR15-095090	95-85	3-3/4 - 3-3/8	TWR15-095085	95-80	3-3/4 - 3-1/8	TWR15-095080
	TWL15-100	100	3-7/8	100-95	3-7/8 - 3-3/4	TWR15-100095	100-90	3-7/8 - 3-1/2	TWR15-100090	100-85	3-7/8 - 3-3/8	TWR15-100085
	TWL15-105	105	-	105-100	-	TWR15-105100	105-95	-	TWR15-105095	105-90	-	TWR15-105090
	TWL15-425	-	4-1/4	-	4-1/4 - 3-7/8	TWR15-425388	-	4-1/4 - 3-3/4	TWR15-425375	-	4-1/4 - 3-1/2	TWR15-425350
	TWL15-110	110	-	110-105	-	TWR15-110105	110-100	-	TWR15-110010	110-95	-	TWR15-110095
	TWL15-115	115	-	115-110	-	TWR15-115110	115-105	-	TWR15-115105	115-100	-	TWR15-115100
TWL15-463	-	4-5/8	-	4-5/8 - 4-1/4	TWR15-463425	-	4-5/8 - 3-7/8	TWR15-463388	-	4-5/8 - 3-3/4	TWR15-463375	
TWLC30	TWL30-080	80	3-1/8	80-75	3-1/8 - 2-15/16	TWR30-080075	80-70	3-1/8 - 2-3/4	TWR30-080070	80-65	3-1/8 - 2-9/16	TWR30-080065
	TWL30-085	85	3-3/8	85-80	3-3/8 - 3-1/8	TWR30-085080	85-65	3-3/8 - 2-15/16	TWR30-085065	85-70	3-3/8 - 2-3/4	TWR30-085070
	TWL30-090	90	3-1/2	90-85	3-1/2 - 3-3/8	TWR30-090085	90-80	3-1/2 - 3-1/8	TWR30-090080	90-75	3-1/2 - 2-15/16	TWR30-090075
	TWL30-095	95	3-3/4	95-90	3-3/4 - 3-1/2	TWR30-095090	95-85	3-3/4 - 3-3/8	TWR30-095085	95-80	3-3/4 - 3-1/8	TWR30-095080
	TWL30-100	100	3-7/8	100-95	3-7/8 - 3-3/4	TWR30-100095	100-90	3-7/8 - 3-1/2	TWR30-100090	100-85	3-7/8 - 3-3/8	TWR30-100085
	TWL30-105	105	-	105-100	-	TWR30-105100	105-95	-	TWR30-105095	105-90	-	TWR30-105090
	TWL30-425	-	4-1/4	-	4-1/4 - 3-7/8	TWR30-425388	-	4-1/4 - 3-3/4	TWR30-425375	-	4-1/4 - 3-1/2	TWR30-425350
	TWL30-110	110	-	110-105	-	TWR30-110105	110-100	-	TWR30-110010	110-95	-	TWR30-110095
	TWL30-115	115	-	115-110	-	TWR30-115110	115-105	-	TWR30-115015	115-100	-	TWR30-115100
	TWL30-463	-	4-5/8	-	4-5/8 - 4-1/4	TWR30-463425	-	4-5/8 - 3-7/8	TWR30-463388	-	4-5/8 - 3-3/4	TWR30-463375
	TWL30-120	120	-	120-115	-	TWR30-120115	120-110	-	TWR30-120110	120-105	-	TWR30-120105
	TWL30-500	-	5	-	5 - 4-5/8	TWR30-500463	-	5 - 4-1/4	TWR30-500425	-	5 - 3-7/8	TWR30-500388
	TWL30-130	130	-	130-120	-	TWR30-130120	130-115	-	TWR30-130115	130-110	-	TWR30-130110
	TWL30-135	135	5-3/8	135-125	5-3/8 - 5	TWR30-135125	135-120	5-3/8 - 4-5/8	TWR30-135120	135-115	5-3/8 - 4-1/4	TWR30-135115
	TWL30-145	145	5-3/4									
	TWL30-150	150	-									
TWL30-155	155	6-1/8										
AVAILABLE UPON REQUEST												

TORQUE WRENCH REACTION ARMS - TWLC

SPX FLOW Bolting Systems offer a varied range of alternative and optional reaction accessories, which help to find a reaction point solution no matter how unusual the bolted application is.

TWLC REACTION BAR TWLC-RB

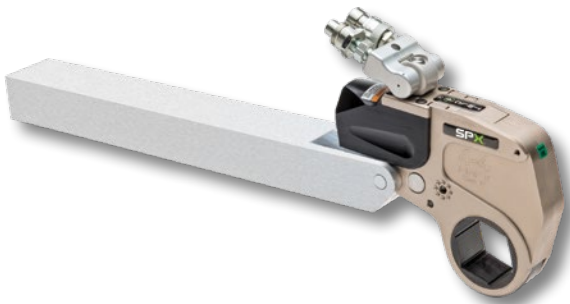

- In-Line Extension Reaction Bar for TWLC wrench: allows extended reach on the same plane
- Pin engagement, no tools required
- Available for full range of tool sizes

Specifications and Dimensional Data

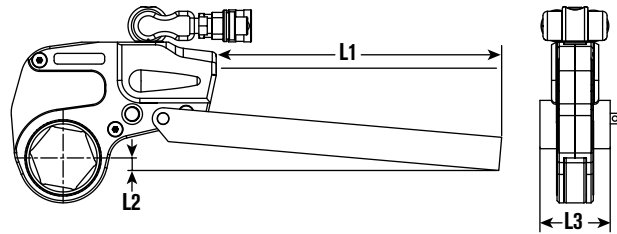

Tool Ref	Order No.	L1		L2		L3		Weight	
		mm	in	mm	in	mm	in	kg	lb
TWLC2	TWLC2-RB	381	15	28	1.10	55	2.17	2.6	5.7
TWLC4	TWLC4-RB	457	18	35	1.38	66	2.60	4.8	10.6
TWLC8	TWLC8-RB	457	18	37	1.46	85	3.35	9	19.8
TWLC15	TWLC15-RB	508	20	40	1.57	102	4.01	14.5	32
TWLC30	TWLC30-RB	508	20	35	1.38	127	5	27	59.5

TWLC REACTION PADDLE TWLC-RP



- Off-Set Reaction Arm for TWLC wrench: allows off-set reaction within wrench profile
- Pin engagement, no tools required
- Light alloy construction
- Available for full range of tool

Specifications and Dimensional Data

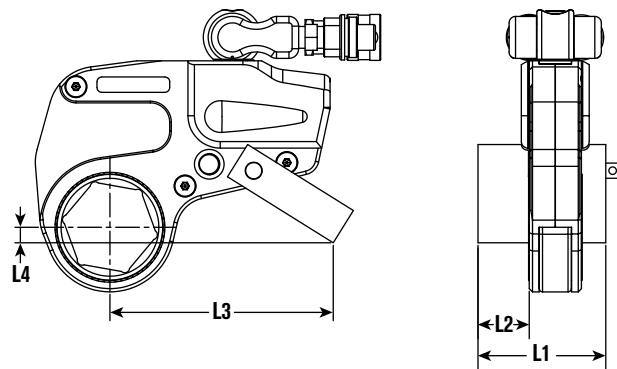

Tool Ref	Order No.	L1		L2		L3		L4		Weight	
		mm	in	mm	in	mm	in	mm	in	kg	lb
TWLC2	TWLC2-RP	84	3.31	35	1.38	142	5.59	13	0.51	0.5	1.1
TWLC4	TWLC4-RP	109	4.29	46	1.81	178	7.01	19	0.75	0.9	2
TWLC8	TWLC8-RP	136.5	5.37	57	2.25	220	8.66	26	1.02	1.8	4
TWLC15	TWLC15-RP	165	6.50	70	2.76	252	9.92	45	1.77	3.5	7.7
TWLC30	TWLC30-RP	200	7.874	86	3.39	317	12.48	44	1.73	6	13.2

**HAVE A UNIQUE APPLICATION?
DOES STANDARD PRODUCT NOT FIT?**



CUSTOM REACTION PADS AND REDUCERS ARE AVAILABLE.

Contact SPX FLOW or an authorized distributor for more details

**WHEN NOTHING ELSE WILL WORK,
SPLIT ADAPTERS ARE MADE TO
ORDER AND AVAILABLE UPON
REQUEST.**



**TWLC15 split adapter,
closed position**



**TWLC15 split adapter,
open position**

TORQUE WRENCH SLIMLINE, TWSL

THE SLIMLINE TORQUE WRENCH

The SlimLine Torque Wrench is engineered to fit inaccessible applications with minimal clearance.

Features & Benefits

- Dynamic engineering modeling (FEA) optimized tool design to extend life and durability
- The SlimLine links use the same quick change Drive Body as the existing TWLC links
- Small nose radius, fits all standard API and ANSI flanges
- Rigid steel body construction with corrosion resistant plating
- Fully enclosed drive mechanism for operator safety
- Swivel manifold has an internal relief valve to prevent retract side over-pressurization
- Multi-axis swivel technology for free positioning of tool and hoses



DRIVE BODY INTERCHANGES WITH THE TWLC & TWSL LINK SIZES

The Drive Body is designed to interchange with the TWLC (Low Clearance) and the new TWSL (SlimLine) Links, lowering your tool investment across each series to broaden your application reach.

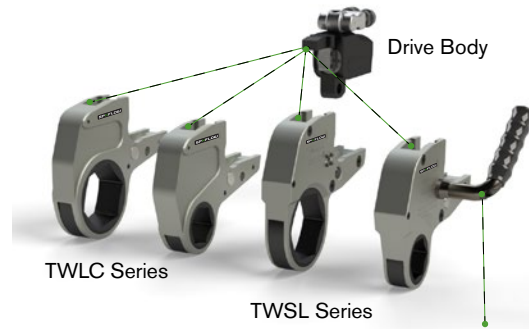

Optional Handle Order #: **DTAS000002**

*Contact your nearest SPXFLOW Bolting Systems sales representative for assistance in sizing the proper tool for your application, or go to spxboltingsystems.com website for details about other available link sizes not listed.

Specifications and Dimensional Data

Size	A	B	C	D	E	F	G
	mm (In)	mm (In)	mm (In)	mm (In)	mm (In)	mm (In)	mm (In)
TWLC2	145 (5.71)	114 (4.49)	128 (5.04)	184.5 (7.26)	8.8 (0.35)	25.0 (0.98)	42.00 (1.65)
TWLC4	168.1 (6.61)	137.0 (5.39)	168.0 (6.61)	224.3 (8.83)	10.72 (0.42)	30.5 (1.20)	52.00 (2.04)

Torque Wrench Drive Body Ordering Information for SlimLine

Drive Body Order No.	Hex Range for SlimLine				SlimLine Min Torque		SlimLine Max. Torque		Weight (Body Only)	
	mm	mm	in	in	Nm	lb-ft	Nm	lb-ft	kg	lb
TWLC2	28	60	1-1/8	2-3/8	301	222	1,681 ~ 2,508	1,240 ~ 1,850	1.0	2.2
TWLC4	46	80	1-13/16	3-1/8	685	505	3,578 ~ 5,708*	2,639 ~ 4,210*	2.0	4.4
TWLC8	57	100	2-1/4	3-15/16	Contact Factory for Details				3.5	7.7

Note: Links are sold separately from the drive body, refer to the tables below.

SlimLine Application Range

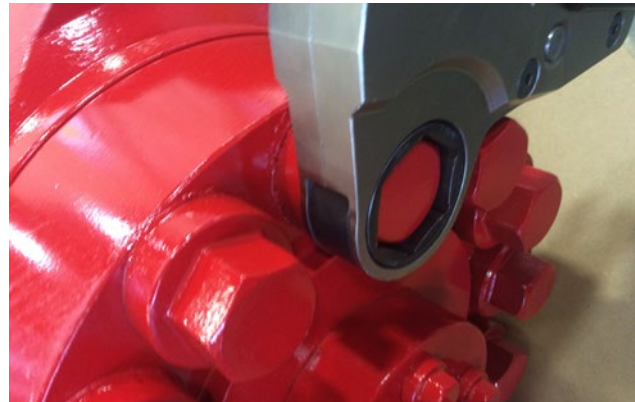
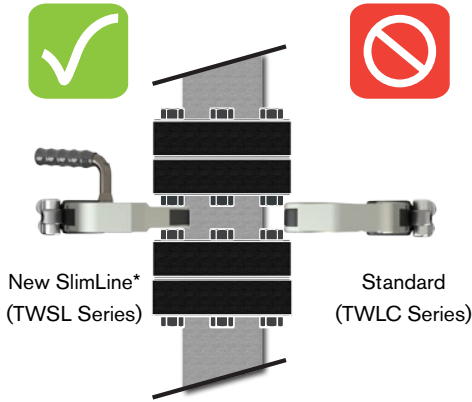

Due to the compact design, the maximum torque of the TWSL links vary depending on link size, * reference the information below for complete details.

The TWSL's narrow width and reduced radius design enables the tool to fit into tight areas where standard low clearance links cannot.

* Shown with optional handle, order # **DFTAS000001** for TWSL2, **DFTAS000002** for TWSL4 & TWSL8.

Torque Wrench Link Ordering Information for SlimLine

Link Order No.	Hex Range for SlimLine				SlimLine Min Torque		SlimLine Max. Torque		Weight (Link Only)	
	mm	mm	in	in	Nm	lb-ft	Nm	lb-ft	kg	lb
TWSL2-#	28	60	1-1/8	2-3/8	301	222	1,681 - 2,508	1,240 - 1,850	1.9 - 2.05	4.2 - 4.5
TWSL4-#	46	80	1-13/16	3-1/8	685	505	3,578 ~ 5,708*	2,639 ~ 4,210*	3.7 - 3.8	8.0 - 8.4
TWSL8-#	57	100	2-1/4	3-15/16			Contact Factory for Details			

Note: The “#” suffix will be replaced with the actual link size in a numeric value.

TWSL2 SlimLine Link Reference Table*

Nut A/F		Link Order No.	Max. Torque		Weight (Link Only)	
mm	in		Nm	lb-ft	kg	lb
32	1-1/4	TWSL2-032	1,681	1,240	1.87	4.1
36	1-7/16	TWSL2-036	1,939	1,430	1.90	4.2
41	1-5/8	TWSL2-041	2,169	1,600	1.93	4.3
46	1-13/16	TWSL2-046	2,508	1,850	1.95	4.3
50	2	TWSL2-050	2,508	1,850	1.96	4.3
55	2-3/16	TWSL2-055	2,508	1,850	1.98	4.4
60	2-3/8	TWSL2-060	2,508	1,850	1.99	4.4

TWSL4 SlimLine Link Reference Table*

Nut A/F		Link Order No.	Max. Torque		Weight (Link Only)	
mm	in		Nm	lb-ft	kg	lb
46	1-13/16	TWSL4-046	3,578	2,639	3.65	8
50	2	TWSL4-050	4,435	3,271	3.72	8.2
55	2-3/16	TWSL4-055	4,838	3,568	3.74	8.2
60	2-3/8	TWSL4-060	5,243	3,867	3.78	8.3
65	2-9/16	TWSL4-065	5,708	4,210	3.79	8.4
70	2-3/4	TWSL4-070	5,708	4,210	3.81	8.4
75	2-15/16	TWSL4-075	5,708	4,210	3.83	8.4
80	3-1/8	TWSL4-080	5,708	4,210	3.82	8.4

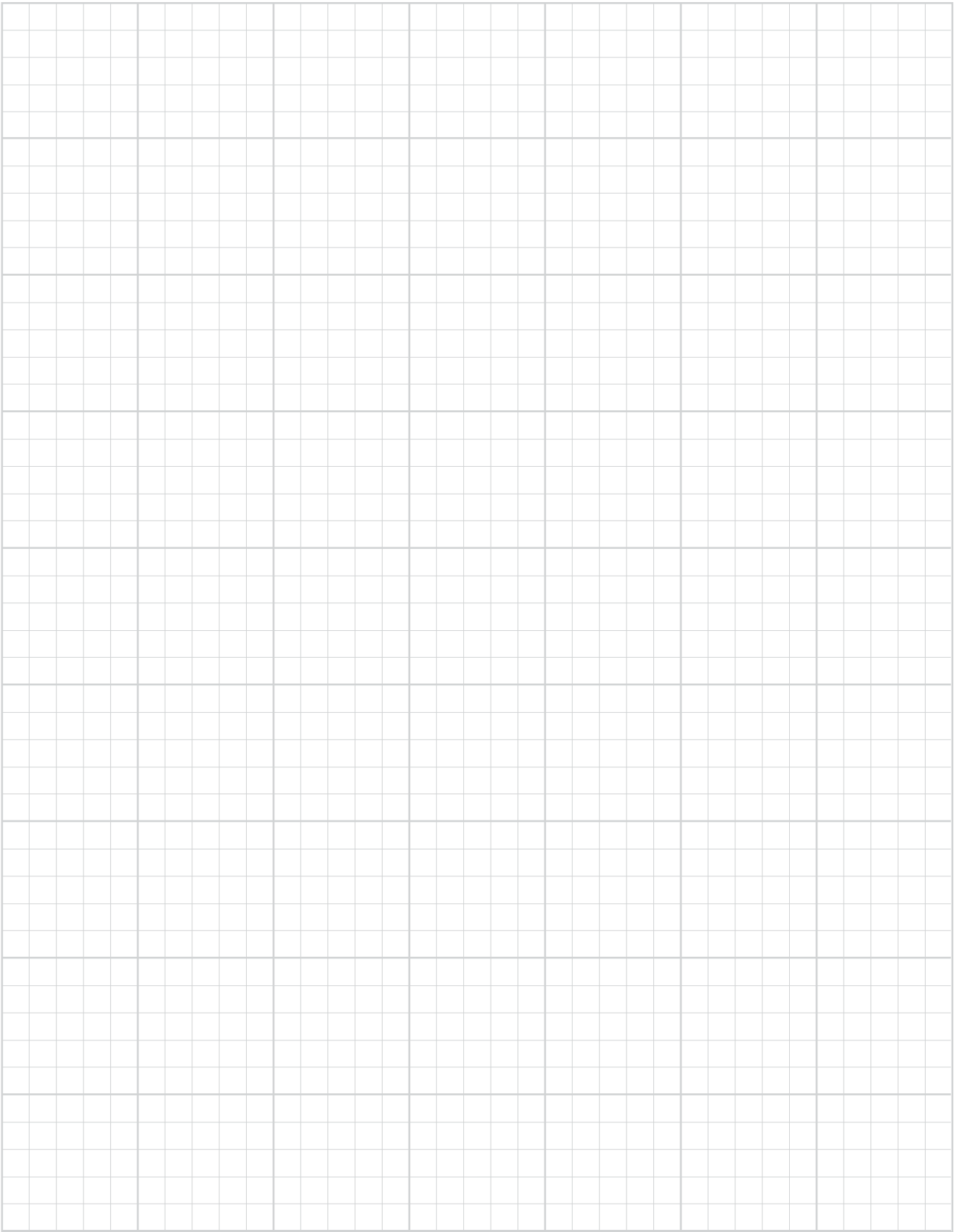

TENSIONERS

HIGH PERFORMANCE TENSIONERS

Page
SRT
ADVANTAGES...36

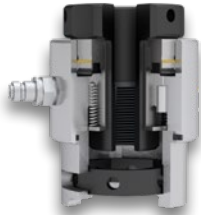

Page
SRT...36-39
Spring Return Tensioner



Page
MRT...40-41
Manual Return Tensioner



Page
WD/WS...42
Wind Tensioners



Page
WDD...43
Up Tower Wind Tensioners



Page
WSD...44
Compact Tower Wind Tensioners



Page
WSS/WSL...45
Foundation Wind Tensioners



Page
SST...60-61
Subsea Tensioners



Note: Certain tensioners may require minimum order quantity - consult factory for details.

SRT ADVANTAGES

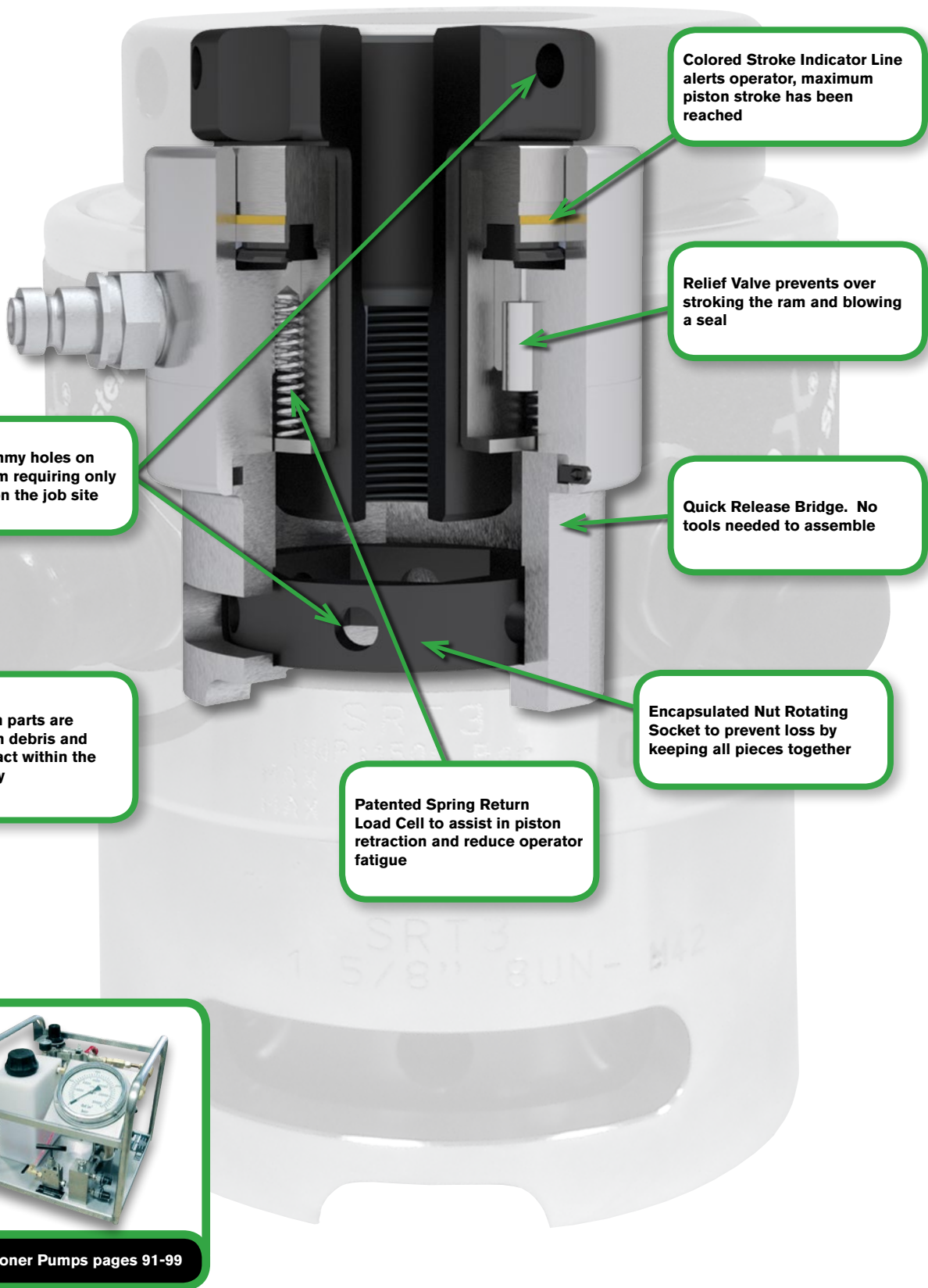

Colored Stroke Indicator Line alerts operator, maximum piston stroke has been reached

Relief Valve prevents over stroking the ram and blowing a seal

Quick Release Bridge. No tools needed to assemble

Encapsulated Nut Rotating Socket to prevent loss by keeping all pieces together

Patented Spring Return Load Cell to assist in piston retraction and reduce operator fatigue

Same size tommy holes on top and bottom requiring only 1 tommy bar on the job site

All mechanism parts are protected from debris and operator contact within the tensioner body



Tensioner Pumps pages 91-99

SRT SPRING RETURN BOLT TENSIONER

The Spring Return design dramatically increases productivity and safety on the job site when compared to older technology manual return tensioners.

- Piston overstroke prevention
- Piston stroke indication
- Compatible with MRT Tensioner range
- Unique quick release bridge adaptation
- Piston/cylinder misalignment compensation
- Bolt coverage from 20 to 115 mm (3/4" to 4") with just 8 tools
- Designed to fit BS1560/ANSI B16.5/API flanges
- Fully enclosed load cell design eliminates entry of debris into piston retraction mechanism
- Piston over-stroke eliminator to prevent over stroking and blowing a seal
- Twin hydraulic couplings for multiple tool connections
- Requires stud to protrude above nut by 1 x bolt diameter
- Application specific tooling available. Contact factory for details.
- 10 mm piston stroke

Max tool pressure: 1,500 bar (21,750 psi)

Bolt protrusion above nut: 1 x bolt diameter (minimum)

BOLT TENSIONER

SPRING RETURN - SRT

Bolt coverage from 20 to 115 mm (3/4" to 4") with just 8 tools



BOLT TENSIONER

SPRING RETURN - SRT

Bolt coverage from 20 to 115 mm
(3/4" to 4") with just 8 tools



Piston stroke: 10mm

Max tool pressure: 1,500 bar (21,750 psi)

Bolt protrusion above nut: minimum 1 x bolt diameter

Specifications and Dimensional Data

(Tool Reference)	Stud Diameter				Tool Load		Hydraulic Area		Approx Wt.		Minimum Bolt Protrusion Above Nut				
	Load Cell Order No.	Metric	Adaptor Kit Order No.	Imperial	Adaptor Kit Order No.	kN	Lbf	mm ²	in ²	kg	lb	Imp bolts		met bolts	
		mm		in								mm	in	mm	in
(SRT0) SRTAS000001	M20	SRTAS000006	3/4"	SRTAS000002	160	35,971	1,067	1.654	1.4	3.1	19	0.75	20	0.79	
	M22	SRTAS000008	7/8"	SRTAS000004							22	0.87	22	0.87	
(SRT1) SRTAS010001	M24	SRTAS010007	1"	SRTAS010003	280	62,950	1,867	2.894	2.7	6	25	0.98	24	0.94	
	M27	SRTAS010009	-	-							-	-	27	1.06	
(SRT2) SRTAS020001	M24	SRTAS020011	1"	SRTAS020003	450	101,169	3,001	4.652	4.1	9	25	0.98	24	0.94	
	M27	SRTAS020013	-	-							-	-	27	1.06	
	M30	SRTAS020014	1-1/8"	SRTAS020005							29	1.14	30	1.18	
	M33	SRTAS020015	1-1/4"	SRTAS020007							32	1.26	33	1.30	
	M36	SRTAS020016	1-3/8"	SRTAS020009							35	1.38	36	1.42	
(SRT3) SRTAS030001	M33	SRTAS030011	1-1/4"	SRTAS030003	660	148,381	4,401	6.822	5.4	11.9	32	1.26	33	1.30	
	M36	SRTAS030012	1-3/8"	SRTAS030005							35	1.38	36	1.42	
	M39	SRTAS030013	1-1/2"	SRTAS030007							38	1.5	39	1.54	
	M42	SRTAS030014	1-5/8"	SRTAS030009							41	1.61	42	1.65	
(SRT4) SRTAS040001	M39	SRTAS040014	1-1/2"	SRTAS040004	1000	224,820	6,668	10.335	8.4	18.5	38	1.5	39	1.54	
	M42	SRTAS040015	1-5/8"	SRTAS040006							41	1.61	42	1.65	
	M45	SRTAS040016	1-3/4"	SRTAS040008							44	1.73	45	1.77	
	M48	SRTAS040017	1-7/8"	SRTAS040010							48	1.89	48	1.89	
(SRT5) SRTAS050001	-	-	2"	SRTAS040012	-	-	-	-	-	-	51	2.01	-	-	
	M52	SRTAS050012	2"	SRTAS050004	1500	337,230	10,003	15.504	13.8	30.4	51	2.01	52	2.05	
	M56	SRTAS050013	2-1/4"	SRTAS050006							57	2.24	56	2.20	
	M60	SRTAS050015	-	-							-	-	60	2.36	
	M64	SRTAS050016	2-1/2"	SRTAS050008							64	2.52	64	2.52	
	M68	SRTAS050018	-	-							-	-	68	2.68	
M70	SRTAS050020	-	-	-							-	70	2.76		
(SRT6) SRTAS060001	-	-	2-3/4"	SRTAS050010	-	-	-	-	-	-	70	2.76	-	-	
	M72	SRTAS060014	2-3/4"	SRTAS060004	2500	562,050	16,671	25.84	23	50.7	70	2.76	72	2.83	
	M76	SRTAS060016	3"	SRTAS060006							76	2.99	76	2.99	
	M80	SRTAS060018	-	-							-	-	80	3.15	
	M85	SRTAS060020	3-1/4"	SRTAS060008							83	3.27	85	3.35	
M90	SRTAS060022	3-1/2"	SRTAS060010	89							3.50	90	3.54		
(SRT7) SRTAS070001	M90	SRTAS070010	3-1/2"	SRTAS070004	3200	719,424	21,339	33.076	32	70.5	89	3.50	90	3.54	
	M95	SRTAS070012	-	-							-	-	95	3.74	
	M100	SRTAS070014	3-3/4"	SRTAS070006							95	3.74	100	3.94	
	-	-	4"	SRTAS070008							102	4.02	-	-	
(SRT8) * SRTAS080001	M105	SRTAS080010	4"	SRTAS080004	4100	921,762	27,340	42.377	45	99.2	102	4.02	105	4.13	
	M110	SRTAS080012	-	-							-	-	110	4.33	
	M115	SRTAS080014	4-1/4"	SRTAS080006							108	4.25	115	4.53	
	-	-	4-1/2"	SRTAS080008							114	4.49	-	-	

Weight excludes puller sleeve
Need to order load cell and adapter kit to have complete tensioner
To convert to long tons, divide lbf by 2240. To convert to short tons, divide lbf by 2000.

All bolt diameters ≤ 1" are UNC and all diameters > 1" are 8UN. All metric threads are Metric Coarse.

* Contact factory for ordering quantity requirement.

Specifications and Dimensional Data

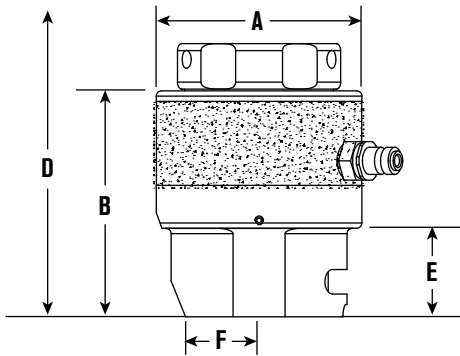

* Toggle Bar data, see page 37

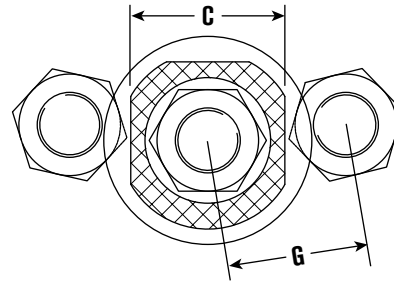

'D' includes an allowance for tool removal after bolt tightening with 10 mm tool stroke

A		B		C		D				E		F		G				Stud Diameter		(Tool Reference)
mm	in	mm	in	mm	in	Imp bolts		met bolts		mm	in	mm	in	Imp bolts		met bolts		Metric	Imperial	Load Cell Order No.
66	2.6	93	3.7	63	2.5	136	5.4	142	5.6	36	1.4	25	1	50.8	2	49.8	2	M20	3/4"	(SRT0)
		93	3.7	63	2.5	142	5.6	144	5.7	36	1.4	25	1	53.6	2.1	51	2	M22	7/8"	SRTAS000001
87	3.4	117	4.6	68	2.7	175	6.9	175	6.9	38	1.5	28	1.1	58.8	2.3	56.5	2.2	M24	1"	(SRT1)
		117	4.6	68	2.7	-	-	178	7	38	1.5	28	1.1	-	-	58.7	2.3	M27	-	SRTAS010001
		120	4.7	72	2.8	181	7.1	-	-	41	1.6	31	1.2	68.3	2.7	44.5	-	-	1-1/8"	-
103	4.1	117	4.6	75	3	175	6.9	175	6.9	38	1.5	30	1.2	65.2	2.6	64.5	2.5	M24	1"	(SRT2)
		117	4.6	75	3	-	-	178	7	38	1.5	30	1.2	-	-	66	2.6	M27	-	SRTAS020001
		120	4.7	80	3.1	181	7.1	184	7.2	41	1.6	30	1.2	67.6	2.7	67.6	2.7	M30	1-1/8"	-
		123	4.8	84	3.3	188	7.4	190	7.5	44	1.7	35	1.4	72.3	2.8	71.9	2.8	M33	1-1/4"	-
		126	5	89	3.5	195	7.7	196	7.7	47	1.9	38	1.5	78	3.1	77	3	M36	1-3/8"	-
118	4.7	123	4.8	88	3.5	190	7.5	192	7.6	44	1.7	35	1.4	75.9	3	76.5	3	M33	1-1/4"	(SRT3)
		126	5	96	3.8	197	7.8	198	7.8	47	1.9	38	1.5	81.1	3.2	80.8	3.2	M36	1-3/8"	SRTAS030001
		130	5.1	96	3.8	203	8	204	8	51	2	42	1.7	83.8	3.3	83.6	3.3	M39	1-1/2"	-
		133	5.2	105	4.1	209	8.2	211	8.3	54	2.1	41	1.6	91	3.6	91	3.6	M42	1-5/8"	-
140.5	5.5	132	5.2	112	4.4	211	8.3	212	8.3	51	2	42	1.7	91.8	3.6	91.6	3.6	M39	1-1/2"	(SRT4)
		135	5.3	114	4.5	217	8.5	218	8.6	54	2.1	45	1.8	95.6	3.8	95.5	3.8	M42	1-5/8"	SRTAS040001
		139	5.5	118	4.6	223	8.8	225	8.9	57	2.2	52	2	100	3.9	100	3.9	M45	1-3/4"	-
		142	5.6	114	4.5	230	9.1	231	9.1	60	2.4	51	2	101.1	4	101.3	4	M48	1-7/8"	-
		145	5.7	120	4.7	236	9.3	-	-	63	2.5	52	2	106.8	4.2	-	-	-	2"	-
175.5	6.9	148	5.8	120	4.7	246	9.7	248	9.8	63	2.5	52	2	114	4.5	115	4.5	M52	2"	(SRT5)
		154	6.1	138	5.4	259	10.2	258	10.2	70	2.8	58	2.3	121.3	4.8	119.1	4.7	M56	2-1/4"	SRTAS050001
		161	6.3	138	5.4	-	-	262	10.3	70	2.8	58	2.3	-	-	122	4.8	M60	-	-
		161	6.3	153	6	272	10.7	273	10.7	76	3	63	2.5	134.3	5.3	132.3	5.2	M64	2-1/2"	-
		161	6.3	153	6	-	-	283	11.1	76	3	63	2.5	-	-	135	5.3	M68	-	-
		161	6.3	153	6	-	-	287	11.3	76	3	63	2.5	-	-	135.2	5.3	M70	-	-
		167	6.6	156	6.1	284	11.2	283	11.1	81	3.2	70	2.8	141.3	5.6	-	-	-	2-3/4"	-
219	8.6	167	6.6	157	6.2	294	11.6	297	11.7	82	3.2	72	2.8	145.4	5.7	146.5	5.8	M72	2-3/4"	(SRT6)
		174	6.9	182	7.2	307	12.1	308	12.1	89	3.5	80	3.1	159.8	6.3	155.5	6.1	M76	3"	SRTAS060001
		174	6.9	182	7.2	-	-	312	12.3	89	3.5	80	3.1	-	-	158.4	6.2	M80	-	-
		180	7.1	190	7.5	320	12.6	323	12.7	95	3.7	84	3.3	169	6.7	165	6.5	M85	3-1/4"	-
		186	7.3	205	8.1	332	13.1	334	13.1	101	4	88	3.5	182	7.2	178.6	7	M90	3-1/2"	-
252	9.9	186	7.3	200	7.9	339	13.3	341	13.4	101	4	88	3.5	179.8	7.1	176.1	6.9	M90	3-1/2"	(SRT7)
		186	7.3	200	7.9	-	-	346	13.6	101	4	88	3.5	-	-	178.9	7	M95	-	SRTAS070001
		192	7.6	200	7.9	352	13.9	356	14	107	4.2	94	3.7	185.3	7.3	184.7	7.3	M100	3-3/4"	-
		199	7.8	210	8.3	364	14.3	-	-	114	4.5	114	4.5	186	7.3	-	-	-	4"	-
282	11.1	199	7.8	210	8.3	374	14.7	378	14.9	114	4.5	114	4.5	196	7.7	195	7.7	M105	4"	(SRT8) *
		199	7.8	210	8.3	-	-	383	15.1	114	4.5	114	4.5	-	-	197	7.8	M110	-	SRTAS080001
		205	8.1	224	8.8	387	15.2	394	15.5	120	4.7	114	4.5	208	8.2	208	8.2	M115	4-1/4"	-
		212	8.3	232	9.1	400	15.7	-	-	127	5	117	4.6	218	8.6	-	-	-	4-1/2"	-

* Contact factory for ordering quantity requirement.

Toggle Bar	10mm x 200mm	SRT/MRT (up to 1-7/8" - M48)	INTTB000010
	14mm x 200mm	SRT/MRT (2" - M52 and above)	INTTB000014

BOLT TENSIONER

MANUAL RETURN - MRT

Bolt coverage from 24 to 100mm (1" to 3-1/2") with just 6 tools



MRT MANUAL RETURN BOLT TENSIONER

Our economy range of bolt tensioners offer low-cost tensioning solutions.

Incorporating our unique quick-release bridge adaptation, a range of adapter kits provide maximum flexibility.

- Piston stroke limit indication
- Piston/cylinder misalignment compensation
- Bolt coverage from 25mm to 89 mm (1" to 3-1/2") with just 6 tools
- Designed to fit BS1560/ANSI B16.5/API flanges
- Unique quick-release bridge adaption
- Application specific tooling available. Contact factory for details.

Made to Order, Consult Factory

Note: Certain tensioners may require minimum order quantity - consult factory for details.

Specifications and Dimensional Data

(Tool Reference)	Stud Diameter				Tool Load		Hydraulic Area		Approx. Wt.		Minimum Bolt Protrusion Above Nut			
	Load Cell Order No.	Adaptor Kit Order No.	Adaptor Kit Order No.	Adaptor Kit Order No.	kN	Lbf	mm ²	in ²	kg	lb	Imp bolts		met bolts	
		Metric	Imperial	Metric							Imperial	mm	in	mm
(MRT1) * MRTAS010001	M24	MRTAS010004	1"	MRTAS010002	280	62,900	1,867	2,894	3	6.6	25	0.98	24	0.94
	M27	MRTAS010005	-	-							-	-	27	1.06
	-	-	1-1/8"	MRTAS010003							29	1.14	-	-
(MRT2) * MRTAS020001	M24	MRTAS020006	1"	MRTAS020002	450	101,100	3,001	4,652	4.5	9.9	25	0.98	24	0.94
	M27	MRTAS020007	-	-							-	-	27	1.06
	M30	MRTAS020008	1-1/8"	MRTAS020003							29	1.14	30	1.18
	M33	MRTAS020009	1-1/4"	MRTAS020004							32	1.26	33	1.30
	M36	MRTAS020010	1-3/8"	MRTAS020005							35	1.38	36	1.42
(MRT3) * MRTAS030001	M33	MRTAS030006	1-1/4"	MRTAS030002	660	148,300	4,401	6,822	5.9	12.98	32	1.26	33	1.30
	M36	MRTAS030007	1-3/8"	MRTAS030003							35	1.38	36	1.42
	M39	MRTAS030008	1-1/2"	MRTAS030004							38	1.50	39	1.54
	M42	MRTAS030009	1-5/8"	MRTAS030005							41	1.61	42	1.65
(MRT4) * MRTAS040001	M39	MRTAS040008	1-1/4"	MRTAS040003	1,000	224,700	6,668	10,335	8.5	18.7	32	1.26	39	1.54
	M42	MRTAS040009	1-5/8"	MRTAS040004							41	1.61	42	1.65
	M45	MRTAS040010	1-3/4"	MRTAS040005							44	1.73	45	1.77
	M48	MRTAS040011	1-7/8"	MRTAS040006							48	1.89	48	1.89
	-	-	2"	MRTAS040007							51	2.01	-	-
(MRT5) * MRTAS050001	M52	MRTAS050007	2"	MRTAS050003	1,500	337,200	10,003	15,505	14	30.8	51	2.01	52	2.05
	M56	MRTAS050008	2-1/4"	MRTAS050004							57	2.24	56	2.20
	M60	MRTAS050009	-	-							-	-	60	2.36
	M64	MRTAS050010	2-1/2"	MRTAS050005							64	2.52	64	2.52
	M68	MRTAS050011	-	-							-	-	68	2.68
	M70	MRTAS050012	-	-							-	-	70	2.76
	-	-	2-3/4"	MRTAS050006							70	2.76	-	-
(MRT6) * MRTAS060001	M72	MRTAS060007	2-3/4"	MRTAS060003	2,500	562,000	16,671	25.84	23	50.6	51	2.01	72	2.83
	M76	MRTAS060008	3"	MRTAS060004							76	2.99	76	2.99
	M80	MRTAS060009	-	-							-	-	80	3.15
	M85	MRTAS060010	3-1/4"	MRTAS060005							83	3.27	85	3.35
	M90	MRTAS060011	3-1/2"	MRTAS060006							89	3.50	90	3.54
(MRT7) * MRTAS070001	M90	MRTAS070006	3-1/2"	MRTAS070003	3,200	719,300	21,339	33	32	70.4	89	3.50	90	3.54
	M95	MRTAS070007	-	-							-	-	95	3.74
	M100	MRTAS070008	3-3/4"	MRTAS070004							95	3.74	100	3.94
	-	-	4"	MRTAS070005							102	4.02	-	-

* Contact factory for ordering quantity requirement.

To convert to long tons, divide lbf by 2240. To convert to short tons, divide lbf by 2000.

Specifications and Dimensional Data

Piston stroke: 15mm (excluding MRT1 - 10mm)

Max tool pressure: 1,500 bar (21,750 psi)

Bolt protrusion above nut: 1 x bolt diameter

'D' includes an allowance for tool removal after bolt tightening with 15mm tool stroke

Weight excludes puller sleeve

To make a complete MRT Tensioner, choose an Adapter Kit and a Load Cell.

Semi-compatible with SRT tensioners. Only compatible with SRT Bridges; NOT puller sleeves. SRT Puller Sleeves cannot be used with MRT Load Cell.

Made to Order, Consult Factory

Note: Customization size available, consult factory for details.

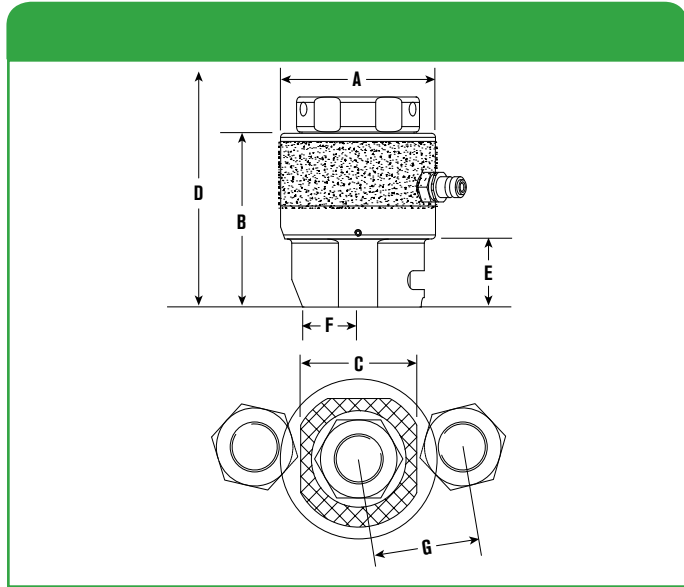

Toggle Bar		10mm x 200mm		SRT/MRT (up to 1-7/8" - M48)										INTTB000010						
		14mm x 200mm		SRT/MRT (2" - M52 and above)										INTTB000014						
A	B	C		D				E		F		G				Stud Diameter		(Tool Reference) Load Cell Order No.		
		mm	in	mm	in	Imp bolts	met bolts	mm	in	mm	in	Imp bolts	met bolts	Metric	Imperial					
85	3.35	97	3.8	68	2.7	166.8	6.6	155.4	6.1	38	1.5	28	1.1	59	2.3	56	2.2	M24	1"	(MRT1) * MRTAS010001
		97	3.8	68	2.7	-	-	158.4	6.2	38	1.5	28	1.1	-	-	59	2.3	M27	-	
		100	3.9	76	3	173.2	6.8	-	-	41	1.6	31	1.2	66	2.6	44	-	-	1-1/8"	
108	4.25	102.5	4	75	3	181.8	7.2	180.4	7.1	38	1.5	30	1.2	68	2.7	67	2.6	M24	1"	(MRT2) * MRTAS020001
		102.5	4	75	3	-	-	183.4	7.2	38	1.5	30	1.2	-	-	69	2.7	M27	-	
		105.5	4.2	80	3.1	188.2	7.4	189.6	7.5	41	1.6	30	1.2	69	2.7	70	2.8	M30	1-1/8"	
		108.5	4.3	84	3.3	194.5	7.7	195.8	7.7	44	1.7	35	1.4	72	2.8	72	2.8	M33	1-1/4"	
147.5	4.9	111.5	4.4	89	3.5	200.9	7.9	201.9	7.9	47	1.9	38	1.5	78	3.1	77	3	M36	1-3/8"	(MRT3) * MRTAS030001
		108.5	4.3	88	3.5	196.5	7.7	197.8	7.8	44	1.7	35	1.4	79	3.1	80	3.1	M33	1-1/4"	
		111.5	4.4	96	3.8	203	8	204	8	47	1.9	38	1.5	81	3.2	81	3.2	M36	1-3/8"	
		115	4.5	96	3.8	209.2	8.2	210.1	8.3	50.5	2	42	1.7	84	3.3	84	3.3	M39	1-1/2"	
147.5	5.8	118	4.6	105	4.1	215.6	8.5	216.3	8.5	53.5	2.1	41	1.6	91	3.6	91	3.6	M42	1-5/8"	(MRT4) * MRTAS040001
		116	4.6	112	4.4	215.2	8.5	216.1	8.5	50.5	2	42	1.7	94	3.7	94	3.7	M39	1-1/4"	
		119	4.7	114	4.5	222	8.7	222	8.7	53.5	2.1	45	1.8	96	3.8	96	3.8	M42	1-5/8"	
		122.5	4.8	118	4.6	227.9	9	228.5	9	57	2.2	52	2	100	3.9	100	3.9	M45	1-3/4"	
		125.5	4.9	114	4.5	234.3	9.2	234.6	9.2	60	2.4	51	2	101	4	101	4	M48	1-7/8"	
180.5	7.1	128.5	5.1	120	4.7	241	9.5	-	-	63	2.5	52	2	107	4.2	-	-	-	2"	(MRT5) * MRTAS050001
		132	5.2	120	4.7	250.6	9.9	251.8	9.9	63	2.5	52	2	117	4.6	117	4.6	M52	2"	
		138.5	5.5	138	5.4	263.3	10.4	262.2	10.3	69.5	2.7	58	2.3	121	4.8	119	4.7	M56	2-1/4"	
		138.5	5.5	138	5.4	-	-	266	10.5	69.5	2.7	58	2.3	-	-	122	4.8	M60	-	
		145	5.7	153	6	276	10.9	276.5	10.9	76	3	63	2.5	134	5.3	132	5.2	M64	2-1/2"	
		145	5.7	153	6	-	-	280.5	11	76	3	63	2.5	-	-	135	5.3	M68	-	
227	8.9	145	5.7	153	6	-	-	282.5	11.1	76	3	63	2.5	-	-	135	5.3	M70	-	(MRT6) * MRTAS060001
		150	5.9	156	6.1	289	11.4	-	-	81	3.2	70	2.8	141	5.6	-	-	-	2-3/4"	
		151	5.9	157	6.2	298.7	11.8	300.9	11.8	82	3.2	72	2.8	149	5.9	151	5.9	M72	2-3/4"	
		158	6.2	182	7.2	311.4	12.3	311.2	12.3	89	3.5	80	3.1	160	6.3	156	6.1	M76	3"	
		158	6.2	182	7.2	-	-	315.2	12.4	89	3.5	80	3.1	-	-	158	6.2	M80	-	
252	10	164	6.5	190	7.5	324.1	12.8	326.6	12.9	95	3.7	84	3.3	169	6.7	165	6.5	M85	3-1/4"	(MRT7) * MRTAS070001
		170	6.7	205	8.1	336.8	13.3	337.9	13.3	101	4	88	3.5	182	7.2	179	7	M90	3-1/2"	
		173	6.8	200	7.9	346	13.6	347	13.7	101	4	88	3.5	180	7.1	176	6.9	M90	3-1/2"	
		6.8	0	7.9	173	-	200	13.9	-	101	351.9	88	3.5	-	-	179	7	M95	-	
7	0	7.9	179	14.1	200	14.3	358.5	107	363.3	94	3.7	185	7.3	185	7.3	M100	3-3/4"			
7.3	0	8.3	186	14.6	210	-	371.2	114	-	114	-	4.5	190	7.5	-	-	-	4"		

* Contact factory for ordering quantity requirement.

For smaller or larger sizes, see SRT product pages.

WIND TENSIONERS

WD/WS

1500 bar
G 1/4"
FF



WDD

WSS & WSL



WSD



Tensioner Pumps pages 91-99

WIND TENSIONERS

Our tensioners have quality designed in with standard features that enhance durability and efficiency to get the job done faster and safer:

Quality Means Lower Life-Cycle Costs:

- Achieves 90% proof load requirement for ISO 898 Grade 10.9 bolts
- Fully enclosed load cell eliminates debris in piston retraction mechanism
- Auto-Engaging Geared Nut Rotator
- Self-energizing, long life seals

Enhanced Usability:

- Piston stroke limit indication
- High pressure swivel coupling (swivel is optional on WSS & WSL)
- 1,350 bar (19,580 psi) maximum operating pressure
- Automatic piston retraction mechanism

Designed with Safety in Mind:

- Overstroke prevention for safe operation
- Anti-slip grip surface
- Tool lifting-strap as standard

Made to Order, Consult Factory

Note: Certain tensioners may require minimum order quantity - consult factory for details.



WIND TENSIONERS UP TOWER - WDD



Specifications and Dimensional Data

WDD UP TOWER WIND TENSIONERS

- Robust Gearbox Drive
- Auto-Engaging Geared Nut Rotator
- Small diameter, high load 2-Stage hydraulic load cell
- Fast application using 1/2" drive
- Cycle counter optional (Add "A" to end of part number)
- Max Pressure: 1,350 bar (19,580 psi)
- Twin coupling optional (Add "TC" to end of part number)

Made to Order, Consult Factory

Note: Customization size available, consult factory for details.

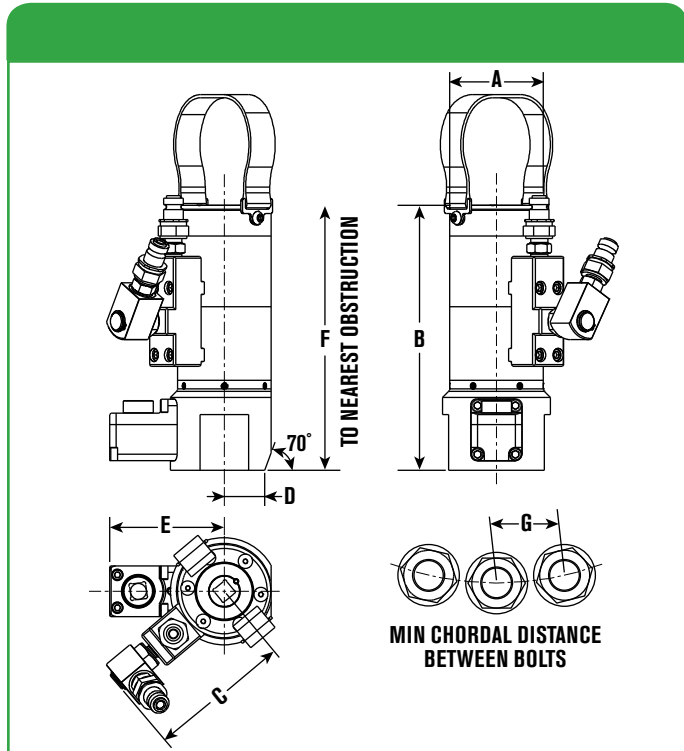

Tool Ref	A		B		C		D		E		F		G	
	mm	In	mm	In	mm	In	mm	In	mm	In	mm	In	mm	In
WDD1-M30	74	2.9	210	8.3	112	4.4	37	1.5	91	3.6	290	11.4	64	2.5
WDD2-M33	79	3.1	214	8.4	115	4.5	39.5	1.6	93	3.7	298	11.7	70	2.8
WDD3-M36	85	3.3	239	9.4	117	4.6	42.5	1.7	96	3.8	332	13.1	76	3.0
WDD4-M39	92	3.6	249	9.8	121	4.8	46	1.8	99	3.9	348	13.7	79	3.1
WDD5-M42	98	3.9	255	10.0	124	4.9	49	1.9	102	4.0	360	14.2	90	3.5

Ordering Information

Order No.	Metric	Required Thread Protrusion		Stroke		Max Load		Hyd Area		Wt	
		mm	In	mm	In	kN	Lbf	sq. mm	sq.in	kg	lb
WDD1-M30	M30	63 - 70	2.5 - 2.8	7	0.3	467	104,900	3458	5.4	6.70	14.8
WDD2-M33	M33	67 - 74	2.6 - 2.9	7	0.3	569	127,900	4215	6.5	7.60	16.8
WDD3-M36	M36	71 - 80	2.8 - 3.1	10	0.4	671	150,800	4970	7.7	9.25	17.0
WDD4-M39	M39	72 - 86	2.8 - 3.4	10	0.4	801	180,000	5931	9.2	11.10	24.5
WDD5-M42	M42	80 - 92	3.1 - 3.6	10	0.4	926	208,100	6856	10.6	12.60	27.8

For twin hydraulic couplings (for multiple tool connection) add "TC" after part number. For cycle counter option, add "A" after code (eg. WDD1-M30A, WDD1-M30TCA)

WIND TENSIONERS

COMPACT TOWER - WSD



Specifications and Dimensional Data

WSD COMPACT TOWER WIND TENSIONERS

- Robust Gearbox Drive
- Auto-Engaging Geared Nut Rotator
- Low height hydraulic load cell
- Fast application using 1/2" drive
- Cycle counter optional (Add "A" to end of part number)
- Maximum operating pressure 1350 bar (19,580 psi)
- Twin coupling optional (Add "TC" to end of part number)

Made to Order, Consult Factory

Note: Customization size available, consult factory for details.

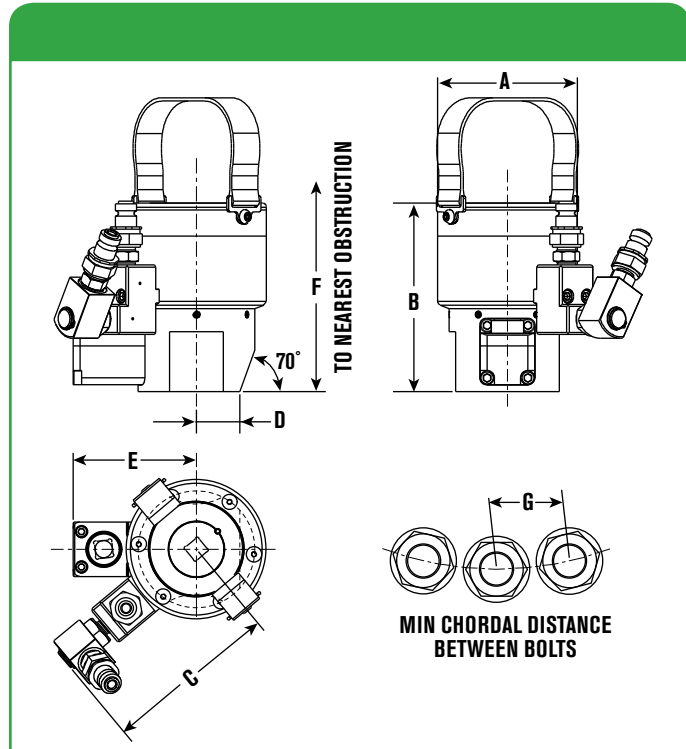

Tool Ref	A		B		C		D		E		F		G	
	mm	In	mm	In	mm	In	mm	In	mm	In	mm	In	mm	In
WSD1-M30	103	4.1	138	5.4	127	5.0	32	1.3	91	3.6	211	8.3	68	2.7
WSD2-M33	112	4.4	140	5.5	132	5.2	35	1.4	93	3.7	218	8.6	74	2.9
WSD3-M36	122	4.8	149	5.9	136	5.4	37	1.5	96	3.8	233	9.2	82	3.2
WSD4-M39	133	5.2	153	6.0	142	5.6	42	1.7	99	3.9	238	9.4	88	3.5
WSD5-M42	140	5.5	157	6.2	146	5.7	45	1.8	102	4.0	250	9.8	93	3.7

Ordering Information

Order No.	Metric	Required Thread Protrusion		Stroke		Max Load		Hyd Area		Wt	
		mm	In	mm	In	kN	Lbf	sq. mm	sq.in	kg	Lbs
WSD1-M30	M30	63 - 81	2.5 - 3.2	7	0.3	467	104,900	3458	5.4	6.60	14.6
WSD2-M33	M33	67 - 86	2.6 - 3.4	7	0.3	569	127,900	4215	6.5	7.60	16.8
WSD3-M36	M36	71 - 93	2.8 - 3.7	10	0.4	671	150,800	4970	7.7	8.80	19.4
WSD4-M39	M39	72 - 95	2.8 - 3.7	10	0.4	801	180,000	5931	9.2	11.20	24.7
WSD5-M42	M42	80 - 96	3.1 - 3.8	10	0.4	926	208,100	6856	10.6	12.20	26.9

For twin hydraulic couplings (for multiple tool connection) add "TC" after part number. For cycle counter option, add "A" after code (eg. WSD1-M30A, WSD1-M30TCA)

WSS & WSL FOUNDATION WIND TENSIONERS

- Suitable for ISO Metric threaded and all-thread bars
- Geared or Manual Nut Rotator
- Long & short stroke models
- Maximum operating pressure 1350 bar (19,580 psi)
- Uses standard system 'nut' for reaction
- Contact factor for optional swivel coupling



WIND TENSIONERS FOUNDATION - WSS & WSL

Made to Order, Consult Factory

Specifications and Dimensional Data

Manual Nut Rotation Version

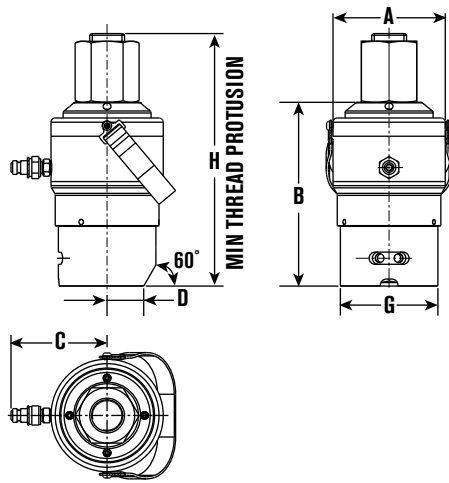

Gearbox Nut Rotation Version

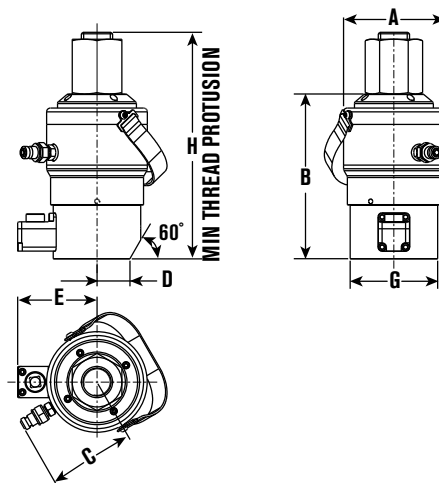

Tool Ref	A		B		C		D		E		G		H	
	mm	In	mm	In	mm	In	mm	In	mm	In	mm	In	mm	In
WSS1/WSS1-10	103	4.1	158	6.2	98	3.9	42	1.7	99	3.9	103	4.1	206	8.1
WSS1/WSS1-11	103	4.1	158	6.2	98	3.9	42	1.7	99	3.9	103	4.1	219	8.6
WSL1/WSL1-10	114	4.5	205	8.1	103	4.1	42	1.7	99	3.9	103	4.1	255	10.0
WSL1/WSL1-11	114	4.5	205	8.1	103	4.1	42	1.7	99	3.9	103	4.1	266	10.5
WSS2/WSS2-125	119	4.7	168	6.6	105	4.1	42	1.7	102	4.0	112	4.4	226	8.9
WSS2/WSS2-138	119	4.7	168	6.6	105	4.1	42	1.7	102	4.0	112	4.4	238	9.4
WSL2/WSL2-125	129	5.1	211	8.3	110	4.3	42	1.7	102	4.0	112	4.4	269	10.6
WSL2/WSL2-138	129	5.1	211	8.3	110	4.3	42	1.7	102	4.0	112	4.4	280	11.0

Ordering Information

Load Cell Order No.	Adaptor Kit** Order No.	Bar Size	Stroke		Max Load		Hyd Area		Wt	
			mm	In	kN	Lbf	sq.mm	sq.in	kg	Lb
FOR GRADE 75 ksi ALL THREAD FOUNDATION BOLTS										
WSS1	WSS1-10	#10	10	0.4	470	105,600	3481	5.4	5.74	12.7
	WSS1-11	#11							5.85	12.9
WSL1	WSL1-10	#10	25	1.0	470	105,600	3481	5.4	9.00	19.8
	WSL1-11	#11							9.20	20.3
FOR GRADE 150 ksi ALL THREAD FOUNDATION BOLTS										
WSS2	WSS2-125	1-1/4"	10	0.4	760	170,800	5630	8.7	8.20	18.1
	WSS2-138	1-3/8"							8.30	18.3
WSL2	WSL2-125	1-1/4"	25	1.0	760	170,800	5630	8.7	12.30	27.1
	WSL2-138	1-3/8"							12.40	27.3

**For manual nut rotation Adaptor Kit add "M" after part number, for gearbox style nut rotation add "GB".

Note: For a complete tensioner, order load cell and adaptor kit.

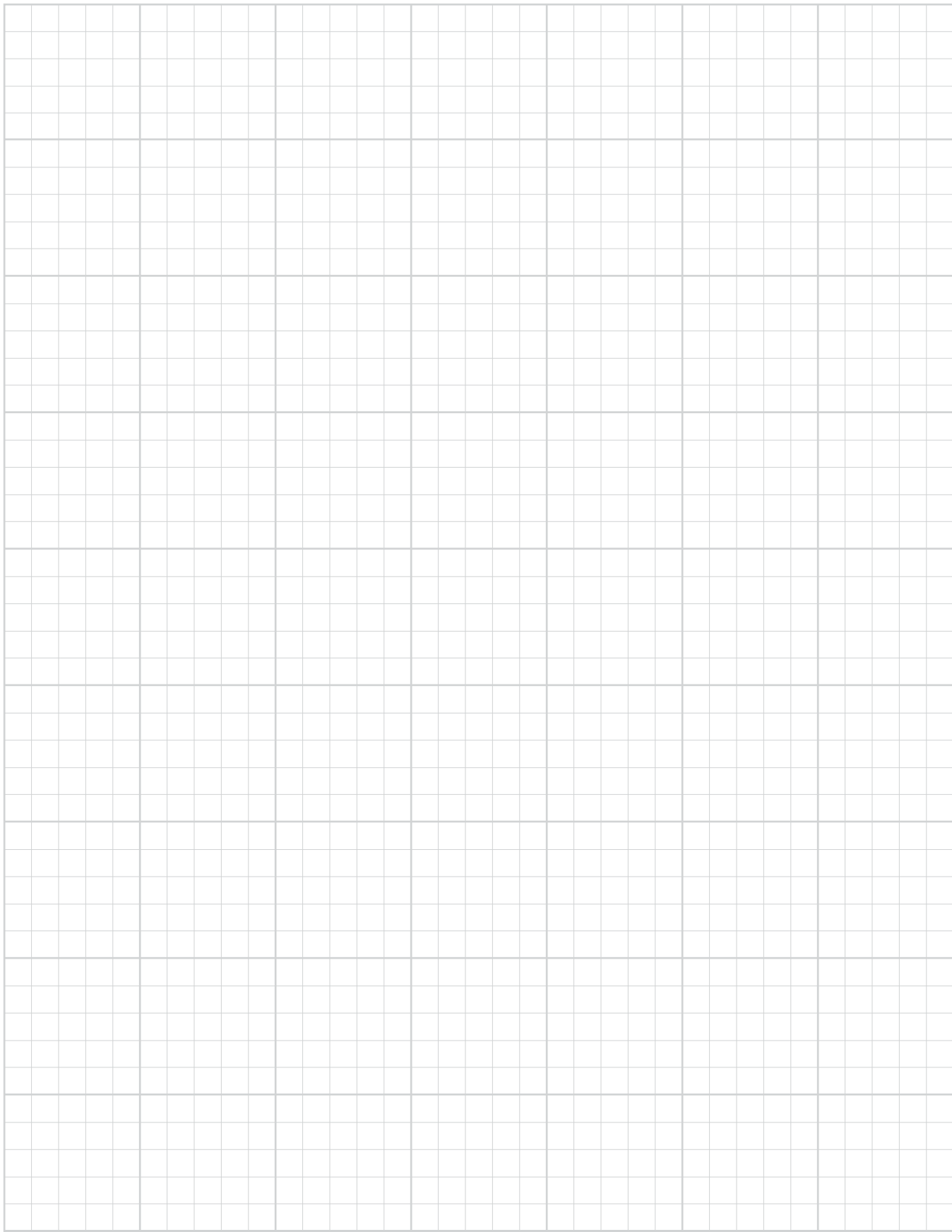

OTHER TOOLS

HIGH PERFORMANCE HIGH FORCE HYDRAULICS

Page
ENS...48-49
Hydraulic Nut Splitters



Page
HNS...54
Hydraulic Nut Splitters



Page
HS...55
Hydraulic Spreaders



Page
FLS15...50-53
Hydraulic Flange Spreader



Page
HFS...56
Pipe Flange Spreader



Page
EHN...57
Hydraulic Nut



NUT SPLITTERS

HYDRAULIC - ENS

M20 to M90 (3/4" to 3-1/2")
bolt diameter



SINGLE ACTING



DOUBLE ACTING
Ideal for Subsea use

ENS HYDRAULIC NUT SPLITTER

Our hydraulic nut splitter offers a reliable and effective solution to the removal of seized and corroded nuts.

- Triple edge replaceable cutting blade
- Blade positioning scale to eliminate bolt damage
- Cutting depth fixed - Nut size adjustable via rotating cylinder!
- Size range from M20 to M90 (3/4" to 3-1/2") bolt diameters
- Designed to fit ANSI, ASME B.16.5 flanges
 - Will work with some API flanges – contact factory for details
- Twin line hydraulic version available for subsea use
- Versatile, reliable and trouble-free operations
- Operates off a standard 700 bar (10,000 psi) pump unit
- Built-in safety relief valve to protect tool & operator

OK FOR SUBSEA



Double acting (subsea) version comes standard with 700 bar, 1/4" NPT, Push to Connect (PTC) couplers. To use with top side pumps, change out couplers to 700 bar, 1/4" NPT, Screw-to-connect style. See page 102 for coupler details.

Ordering Information

TO SPECIFY AN ENS SOLUTION:

1. Use the table located on the next page to identify the nut you need to split and select the appropriate head.
2. Select a single or double acting cylinder. For subsea applications only select double acting cylinders.
3. Order extra cutting blades (optional).

Accessory Ordering Information

Order No.	Description
ENSBL010001	Cutting blade for ENS1
ENSBL020001	Cutting blade for ENS2
ENSBL030001	Cutting blade for ENS3
ENSBL040001	Cutting blade for ENS4

Specifications and Dimensional Data

Pick One Cylinder +
One Head

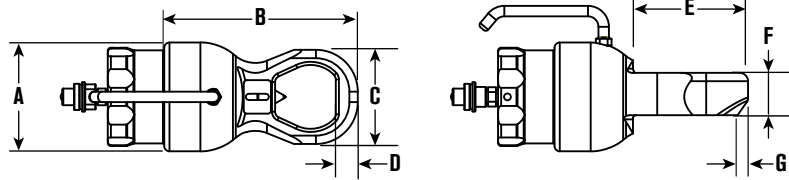

(Tool Reference) Order Numbers

STANDARD Standard Cylinder Single Acting	OPTIONAL Subsea * Cylinder Double Acting	Head	Bolt Dia.	Nut A/F	Bolt Dia.	Nut A/F	A		B		C		D		E		F		G		Wt	
			Metric	mm	Imperial	in	mm	in	mm	in	mm	in	mm	in	mm	in	mm	in	mm	in	kg	lb
ENSAS010001	ENSAS010004	ENSAS010002	M20	30	3/4"	1-1/4	104	4.1	228	9.0	76	3.0	18	0.7	104	4.1	40.5	1.6	9	0.4	6.7	14.8
			M22	32	7/8"	1-7/16																
			M24	36	1"	1-3/8																
			M27	41																		
		ENSAS010003	M20	30	3/4"	1-1/4	104	4.1	239	9.4	90	3.5	21	0.8	110	4.3	40.5	1.6	10	0.4	6.9	15.2
			M22	32	7/8"	1-7/16																
			M24	36	1"	1-3/8																
			M27	41	1-1/8"	1-13/16																
			M30	46	1-1/4"	2																
			M33	50																		
ENSAS020001	ENSAS020004	ENSAS020002	M30	46	1-1/8"	1-13/16	138	5.4	305	12.0	102	4.0	22	0.9	132	5.2	57.5	2.3	6	0.2	15.8	34.8
			M33	50	1-1/4"	2																
			M36	55	1-3/8"	2-3/16																
			M39	60	1-1/2"	2-3/8																
		ENSAS020003	M30	46	1-1/8"	1-13/16	138	5.4	314	12.4	114	4.5	23	0.9	141	5.6	57.5	2.3	6	0.2	16	35.3
			M33	50	1-1/4"	2																
			M36	55	1-3/8"	2-3/16																
			M39	60	1-1/2"	2-3/8																
			M42	65	1-5/8"	2-9/16																
			M45	70	1-3/4"	2-3/4																
ENSAS030001	ENSAS030006	ENSAS030002	M45	70	1-3/4"	2-3/4	190	7.5	406	16.0	132	5.2	28	1.1	189	7.4	80.5	3.2	8	0.3	42	92.6
			M48	75	1-7/8"	2-15/16																
			M52	80	2"	3-1/8																
		ENSAS030003	M45	70	1-3/4"	2-3/4	190	7.5	416	16.4	145	5.7	30	1.2	199	7.8	80.5	3.2	8	0.3	42.5	93.7
			M48	75	1-7/8"	2-15/16																
			M52	80	2"	3-1/8																
		ENSAS030004	M45	70	1-3/4"	2-3/4	190	7.5	426	16.8	160	6.3	31.5	1.2	200	7.9	80.5	3.2	7	0.3	43	94.8
			M48	75	1-7/8"	2-15/16																
			M52	80	2"	3-1/8																
			M56	85	2-1/4"	3-1/2																
			M60	90	2-1/2"	3-7/8																
			M64	95																		
		ENSAS030005	M45	70	1-3/4"	2-3/4	190	7.5	437	17.2	174	6.9	35	1.4	204	8.0	80.5	3.2	9	0.4	44	97.0
			M48	75	1-7/8"	2-15/16																
			M52	80	2"	3-1/8																
			M56	85	2-1/4"	3-1/2																
			M60	90	2-1/2"	3-7/8																
			M64	95	2-3/4"	4-1/4																
			M68	100																		
		M72	105																			
ENSAS040001	ENSAS040004	ENSAS040002	M76	110	2-3/4"	4-1/4	235	9.3	474	18.7	189	7.4	36.5	1.4	235	9.3	110.5	4.4	4	0.2	73	160.9
			M80	115	3"	4-5/8																
		ENSAS040003	M76	110	2-3/4"	4-1/4	235	9.3	495	19.5	219	8.6	41	1.6	240	9.4	110.5	4.4	3	0.1	75	165.3
			M80	115	3"	4-5/8																
			M85	120	3-1/4"	5																
			M90	130	3-1/2"	5-3/8																

Order a cylinder and a head to make complete nutsplitter. Cylinders are interchangeable with heads within specific size ranges. Each are sold separately.
* Subsea can be use topside.

HYDRAULIC SPREADER

FLS15

15 Metric Ton Capacity
700 bar/10,000 psi



FLS15
WITH SERRATED SHOES—WEDGE FULLY OPENED



FLS15-ST
WITH STEPPED SHOES—WEDGE CLOSED



FLS15 HYDRAULIC SPREADER

SPX FLOW Bolting Systems is pleased to introduce the FLS15 hydraulic spreader. This unit is ideal for pipe and flange repair. It can also be used for removing elbows, gasket and metal seal replacement on couplers, heavy equipment maintenance, and many other tasks. The spreader is capable of developing up to 15 metric tons of force, is lightweight, and easy to use due to its ergonomic design.

- 15 metric ton (33,000 pound) wedge-driven spreader
- Jaws fully supported by wedge for excellent durability
- Low friction provided by heavy-duty extended-life lubricant
- Ideal for flanges with narrow gaps - only 5 mm (0.2 inches) required for entry
- Very high strength due to special alloy used
- Compact and lightweight design - only 287 mm (11.28 inches) long at a weight of 3.2 kg (7 pounds)
- Easy to use - ergonomically balanced handle (optional)
- Suitable for the offshore environment due to superior corrosion resistance
- Quick adjustments for various tasks due to interchangeable shoes (both stepped and serrated)
- Easy and quick maintenance - Only T40 Torx tool required
- Includes female half coupler - mates to standard 3/8" male half coupler (No. 9798)
- Both serrated- and stepped-shoe versions available

FLS15 HYDRAULIC SPREADER

This hydraulic spreader operates using the integrated wedge concept. It is ideal for creating space for flange surface cleaning and repair, and for gasket replacement. The spreader is single-acting, and should be used with a hydraulic pump capable of holding pressure. Maximum operating pressure is 700 bar (10,000 psi).

Spreading Force:

Maximum 15 metric tons (33,000 lb) per tool at 700 bar (10,000 psi). It is recommended that the tools be used in pairs, providing a maximum combined force of 30 metric tons (66,000 lb).

Typical Applications:

- Pipe and flange repair
- Removing elbows
- Couplers - gasket and metal seal replacement
- Heavy equipment maintenance

Specifications and Dimensional Data

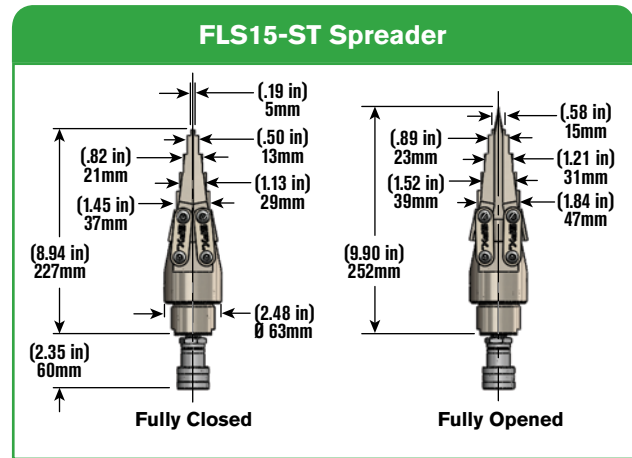
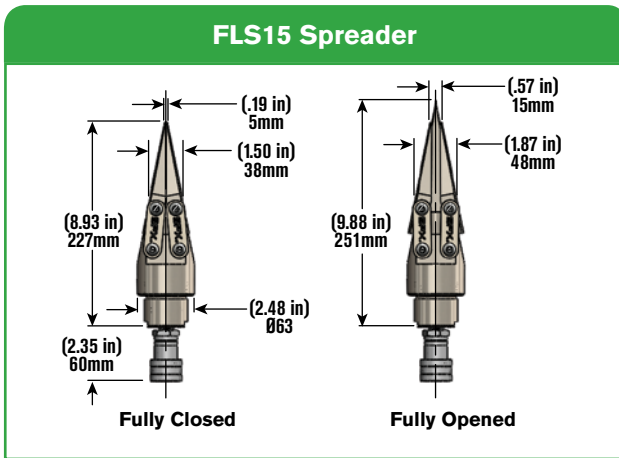

Order No.	Maximum Spreading Force	Minimum Tip Clearance	Maximum Tip Spread	Spreader Type	Oil Capacity	Weight	Maximum Operating Pressure
FLS15 or FLS15-ST	15 Metric Tons (33,000 Pounds)	5 mm (0.197 Inches)	15 mm (0.59 Inches)	Hydraulic	16 cc (1 Cubic Inch)	3.2 kg (7 Pounds)	700 bar (10,000 psi)

Available FLS15 Accessories



*Two shoes required per spreader.

Recommended Components

Description	Part Number (Europe)	Part Number (Americas & Asia)
Two Speed, Single-Acting Hand Pump	P19L	P19L
Hydraulic Hose Assembly	9764E	9764
Pressure Gauge	9040E (Primary Units = bar)	9040 (Primary Units = psi)
Gauge Adapter	9670	9670
Coupler (male half coupler)	9798	9798
2 Station Manifold with Needle Valves	9642	9642
Female Half Coupler	9796	9796
Male Connector, 3/8	9682	9682

HYDRAULIC SPREADER KIT

FLS15 KIT (TOPSIDE CASE)

15 Metric Ton Capacity
700 bar/10,000 psi



*The spreader kit is available in various combinations, with a standard-duty case that is easy to transport.

FLS FLANGE SPREADER KIT

- Standard duty blow molded case organizes and protects the complete spreading kit
- Extra storage space for additional step shoes and up to 3 step blocks
- 15 metric ton wedge-driven spreader
- Jaws fully supported by wedge for excellent durability

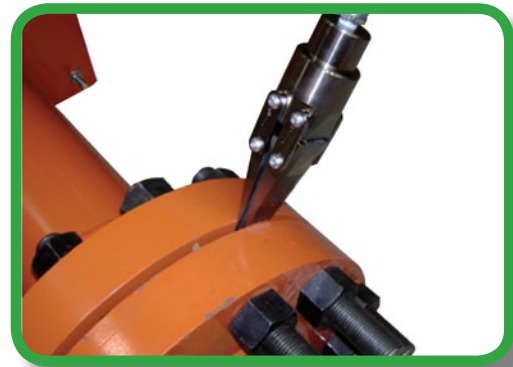

FLS15 KIT (TOPSIDE CASE)

Kit Components	Description	Order No							
		FLS15-FBK	FLS15-MBK	FLS15-FBK-ST	FLS15-MBK-ST	FLS15-FBP	FLS15-MBP	FLS15-FBP-ST	FLS15-MBP-ST
Component	Description	CE	CE	CE	CE				
FLS15	Spreader, Hydraulic	2	1	-	-	2	1	-	-
FLS15-ST	Spreader, Hydraulic Stepped	-	-	2	1	-	-	2	1
SB15	Aluminum Holding Block	2	3	2	3	2	3	2	3
P19L	Lightweight Hand Pump	1	1	1	1	1	1	1	1
Manifold Assy	Manifold, 2 Needle Valve Assembly (Incl. 2 Gauges)	1	-	1	-	1	-	1	-
2008410	Handle for FLS15	2	1	2	1	2	1	2	1
2008650	Standard Case	1	1	1	1	1	1	1	1

FLS FLANGE SPREADER KIT

- Heavy duty case is more rugged and compact, ideal for offshore applications
- Weather proof gasket seal and pressure equalization valve
- Tighter product spacing for easier helicopter transport
- 15 metric ton wedge-driven spreader
- Jaws fully supported by wedge for excellent durability
- All kits are CE rated.



HYDRAULIC SPREADER KIT FLS15 KIT (OFFSHORE CASE)

15 Metric Ton Capacity
700 bar/10,000 psi



*Spreader kit in various combinations available, all in a heavy duty cases; easy to transport and stock.

FLS15 KIT (OFFSHORE CASE)

Kit Components		Order No			
		FLS15-FSK	FLS15-FSK-ST	FLS15-MSK	FLS15-MSK-ST
Component	Description	Spreader kit Tandem, Serrated	Spreader kit Tandem, Stepped	Spreader only kit, Serrated	Spreader only kit, Stepped
FLS15	Spreader, Hydraulic	2	-	1	-
FLS15-ST	Spreader, Hydraulic Stepped	-	2	-	1
SB15	Aluminum Holding Block	2	2	1	1
P19L	Lightweight Hand Pump with Gauge	1	1	-	-
3000827	Manifold, 2 Needle Valve Assembly (Incl. 2 Gauges)	2	2	-	-
2008577	Heavy Duty Case, Large	1	1	-	-
3000832	Heavy Duty Case, Small	-	-	1	1

NUT SPLITTERS

HYDRAULIC - HNS

15 & 25 Ton Capacity
700 bar/10,000 psi



HNS150



HNS150A



HNS225

HNS HYDRAULIC NUT SPLITTER

- “Dial-in” feature on HNS150 makes adjustment of splitter simple, without the worry of damaging the bolt
- Specially designed “tool steel” cutter blade penetrates the nut to the precise point where it cracks, stopping short of the bolt threads
- Nut splitter features a dramatically improved cutter blade with an 800% greater resistance to chipping and breaking over previous models
- All models feature a rugged one-piece cutting frame coupled to a heavy-duty hydraulic cylinder
- Compact size allows you to use it in confined areas where it will deliver enough force to split the toughest “fused” or rusted-on grade 2H nuts
- Simply split nut on one side, spin nut splitter 1/2 turn and make second cut on opposite side; nut separates into halves for easy removal
- Uses a standard 3/8" high flow coupler



Align mark on cutter blade with scale.

Specifications and Dimensional Data

HNS150A

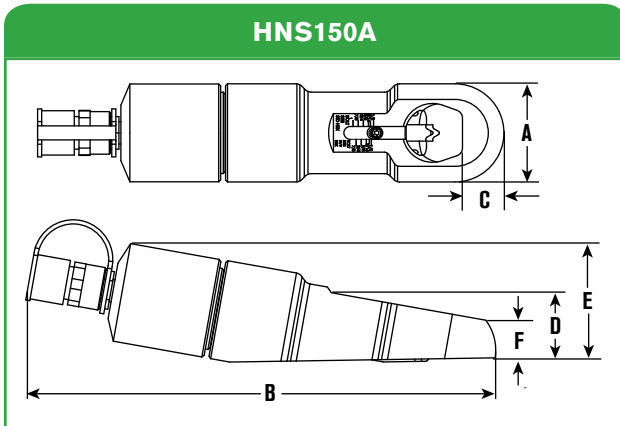

HNS150 & HNS225

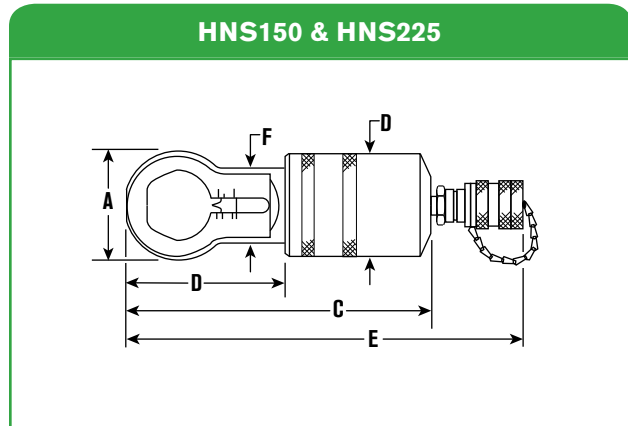

Tool Model	A		B		C		D		E		F		HEAD THICKNESS		REPLACEMENT BLADE	TOOL Wt	
	mm	in	mm	in	mm	in	mm	in	mm	in	mm	in	mm	in		kg	lb
HNS150	73	2.875	86	3.375	200	7.875	70	2.75	264	10.375	52	2.0625	25	1	308840	3.7	8.1
HNS150A	77	3.02	361	14.2	26	1.03	54	2.11	94	3.7	29	1.16	25	1	351985	7.2	15.8
HNS225	108	4.25	152	6	365	14.375	98	3.875	N/A	N/A	83	3.25	38	1.5	308022	13.2	29

CAPACITIES (by Nut Grade)

Order No.	2 or A		5 or B		8 or C		2H	
	in. hex		in. hex		in. hex		in. hex	
HNS150	1/2 - 1-1/2		1/2 - 1-1/2		1/2 - 1-5/16		1/2 - 1-1/8	
HNS150A	1/2 - 1-1/2		1/2 - 1-1/2		1/2 - 1-5/16		1/2 - 1-1/8	
HNS225	1-1/8 - 2-1/4		1-1/8 - 2-1/4		1-1/8 - 2-1/4		1-1/8 - 1-11/16	

HS HYDRAULIC SPREADERS

- Often used to position and align heavy pipes and flanges for easier bolting.
- Conforms to ASME B30.1 standard.
- High strength alloy steel forged upper and lower jaws on HS2000.
- Jaws are spring-return; retract automatically when pressure is released.
- Uses a standard 3/8" high flow coupler

HYDRAULIC SPREADERS

HS

1-1/2 Short Tons
700 bar/10,000 psi



HS2000
(Forged Steel)



HS3000
(High Grade Ductile Iron)

Specifications and Dimensional Data

HS2000 SPECIFICATIONS

Maximum Rated Capacity: 0.91 metric tons @ 690 bar (1 short ton @ 10,000 psi)

Maximum Spread: 101 mm (4")

Minimum Clearance Required: 14.3 mm (9/16")

Oil Required: 10.3 mL (0.63 in³)

HS3000 SPECIFICATIONS

Maximum Rated Capacity: 1.36 metric tons @ 690 bar (1-1/2 short ton @ 10,000 psi)

Maximum Spread: 292 mm (11-1/2")

Minimum Clearance Required: 31.8 mm (1-1/4")

Oil Required: 57.4 mL (3.50 in³)

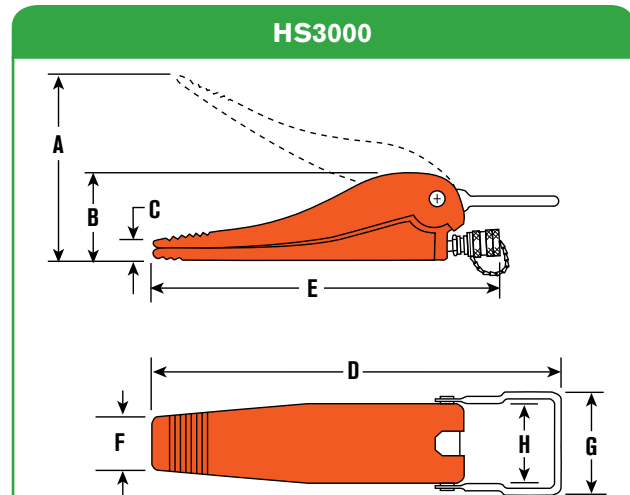
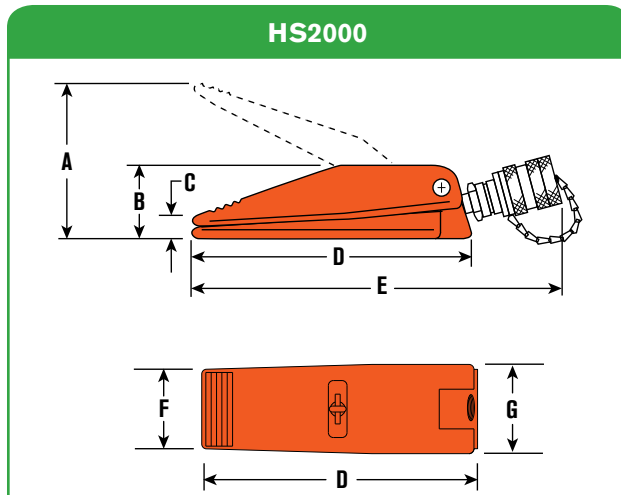

Order Number	Capacity	A	B	C	D	E	F	G	H	Oil Capacity	Min. Clearance Required	Wt
	metric ton (short ton)	mm (in)	mm (in)	mm (in)	mm (in)	mm (in)	mm (in)	mm (in)	mm (in)	mL (cu in)	mm (in)	kg (lb)
HS2000	0.91 (1)	101 (4)	50.8 (2)	14.3 (9/16)	176 (6-15/16)	236.5 (9-5/16)	50.8 (2)	57.1 (2-1/4)	-	10.3 (0.63)	14.3 (9/16)	2.2 (4.8)
HS3000	1.36 (1-1/2)	292 (11-1/2)	108 (4-1/4)	30.2 (1-3/16)	511 (20-1/8)	450.9 (17-3/4)	57.1 (2-1/4)	142.9 (5-5/8)	92 (3-5/8)	57.4 (3.5)	31.8 (1-1/4)	10 (22)

Value(s) shown in short tons (2,000 lb). To convert to long tons, multiply by 0.893. To convert to metric tons, multiply by 0.907

PIPE FLANGE HYDRAULIC SPREADER - HFS

5 & 10 Ton Capacity
700 bar/10,000 psi



HFS3A

HFS PIPE FLANGE SPREADER

- You'll never again have to resort to "hammer and chisel" methods that waste time and effort. Flange spreaders should be used in pairs to provide even spreading force.
- Standard 60° wedge is suitable for most flanges; 30° "thin" and 60° "blunt" wedges are optional.
- The HFS3A is designed for applications where total thickness of flanges and max. spread gap is 3" or less and flange bolts are a min. of 11/16" dia.
- Use HFS6A if total thickness of flanges and max. spread gap is 6" or less, and flange bolts are a min. of 13/16" dia.
- Max working pressure 700 bar (10,000 psi)
- Uses a standard 3/8" high flow coupler

Specifications and Dimensional Data

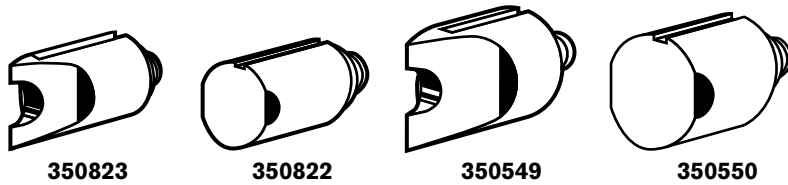

Order No.	Capacity Metric tons Short tons	Standard Wedge Type	Optional Wedges		Min. Flange Opening			Max. Flange Opening			Combined Flange Opening mm in	Min. Pin Dia.	Wt lb kg
			30°	60°	60°	60°	30°	60°	60°	30°			
			Thin	Blunt	mm in	mm in	mm in	mm in	mm in	mm in			
HFS3A	4.5	60° Sharp	350823	350822	1,6	25,4	1,6	38,1	38,1	18,3	76,2	17,4	4,1
	5				1/16"	1"	1/16"	1-1/4"	1-1/4"	23/32"			
HFS6A	9	60° Sharp	350549	350550	1,6	38,1	1,6	50,8	50,8	24,6	152,4	20,6	8,2
	10				1/16"	1-1/2"	1/16"	2"	2"	31/32"			

Value(s) shown in short tons (2,000 lb). To convert to long tons, multiply by 0.893. To convert to metric tons, multiply by 0.907.

EHN TOP COLLAR HYDRAULIC NUT

Our precision machined top collar hydraulic nuts offer a quick, accurate and cost effective solution to simultaneous tightening of multiple bolted joints.

In addition to standard features normally associated with hydraulic nuts, our system also provides the following benefits:

- Compact enough to fit the most confined spaces
- Maximum load generated at 1,500 bar (21,750 psi)
- Energized from either a hand operated or air driven pump
- Custom Hydraulic Nut designs available
- Alternative Bottom Collar and Shim type versions available
- Made to Order, Consult Factory

Note: Hydraulic Nuts will require minimum order quantity - consult factory for details.

HYDRAULIC NUT TOP COLLAR - EHN

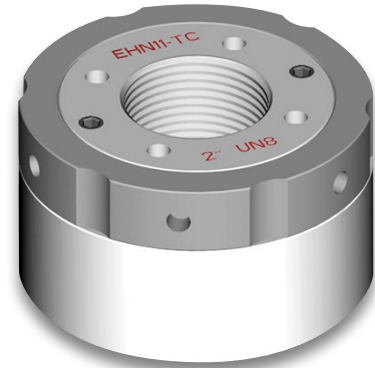

Specifications and Dimensional Data

Tool Ref.	THREAD		INITIAL LOAD		HYDRAULIC AREA		NUT DIAM.		HEIGHT		STROKE	
	Metric	in	kN	Ton F	mm ²	in ²	mm	in	mm	in	mm	in
EHN1-TC	M20	3/4	180	18.07	1200	1.86	68	2.7	55	2.2	5	0.2
EHN2-TC	M22	7/8	180	18.07	1200	1.86	68	2.7	55	2.2	5	0.2
EHN3-TC	M24	1	195	19.57	1300	2.02	72	2.8	55	2.2	5	0.2
EHN4-TC	M27	1-1/8	210	21.08	1400	2.17	75	3.0	55	2.2	5	0.2
EHN5-TC	M33	1-1/4	250	25.09	1667	2.58	82	3.2	57	2.2	5	0.2
EHN6-TC	M36	1-3/8	300	30.11	2001	3.10	88	3.5	57	2.2	5	0.2
EHN7-TC	M39	1-1/2	340	34.12	2267	3.51	93	3.7	58	2.3	5	0.2
EHN8-TC	M42	1-5/8	400	40.15	2667	4.13	100	3.9	62	2.4	6	0.2
EHN9-TC	M45	1-3/4	460	46.17	3067	4.75	106	4.2	64	2.5	6	0.2
EHN10-TC	M48	1-7/8	500	50.18	3334	5.17	110	4.3	64	2.5	6	0.2
EHN11-TC	M52	2	560	56.20	3734	5.79	117	4.6	67	2.6	6	0.2
EHN12-TC	M56	2-1/4	720	72.26	4801	7.44	128	5.0	74	2.9	8	0.3
EHN13-TC	M64	2-1/2	900	90.33	6002	9.30	141	5.6	77	3.0	8	0.3
EHN14-TC	M68	2-3/4	1000	100.37	6668	10.34	150	5.9	78	3.1	8	0.3
EHN15-TC	M76	3	1200	120.44	8002	12.40	162	6.4	81	3.2	8	0.3
EHN16-TC	M80	3-1/4	1400	140.51	9336	14.47	174	6.9	87	3.4	10	0.4
EHN17-TC	M90	3-1/2	1600	160.59	10669	16.54	187	7.4	95	3.7	10	0.4
EHN18-TC	M95	3-3/4	1700	170.62	11336	17.57	194	7.6	102	4.0	10	0.4
EHN19-TC	M100	4	1900	190.70	12670	19.64	205	8.1	110	4.3	10	0.4
EHN20-TC	M110	4-1/2	2200	220.81	14671	22.74	223	8.8	120	4.7	10	0.4
EHN21-TC	M125	5	2400	240.88	16004	24.81	239	9.4	135	5.3	15	0.6
EHN22-TC	M140	5-1/2	2900	291.06	19338	29.97	261	10.3	145	5.7	15	0.6
EHN23-TC	M150	6	3400	341.24	22673	35.14	282	11.1	160	6.3	15	0.6

NOTE: EHN#-TC" is not a part number that can be ordered please contact factory for ordering information.

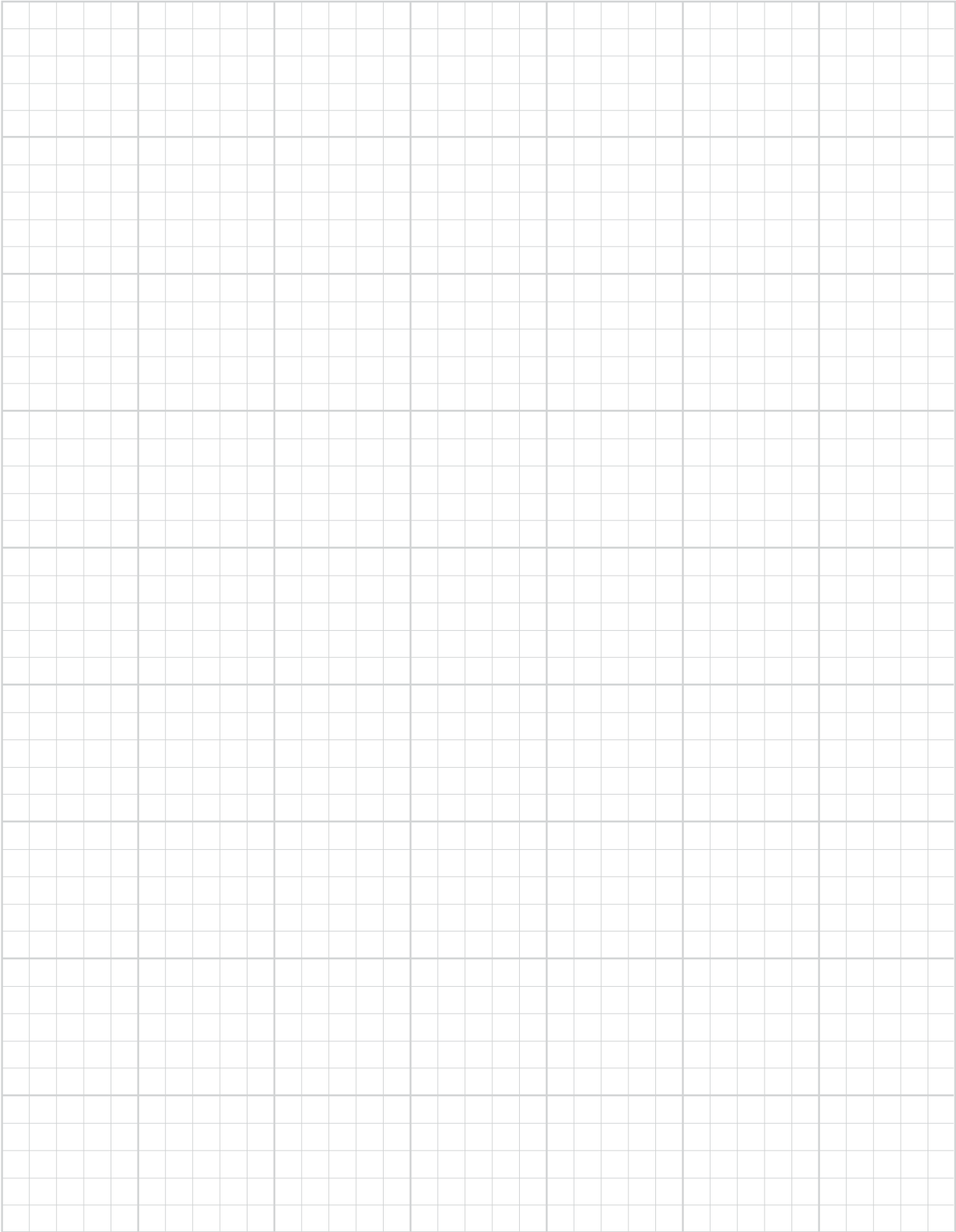

SUBSEA TOOLS

HIGH PERFORMANCE HIGH FORCE HYDRAULICS

Page
SST...60-61
Subsea Stud Tensioner



Page
SFP...62-65
Subsea Flange Pullers

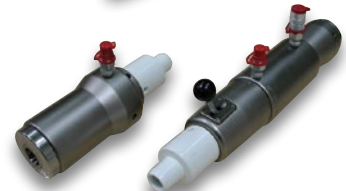

Page
**SUBSEA
ACCESSORIES...66-67**



OTHER TOOLS FOR SUBSEA

Page
ENS...48-49
Hydraulic Nut Splitters



Page
TWHC...14-15
High Cycle Torque Wrench



OK FOR SUBSEA



Page
TWLC...24-29
Low Clearance Torque Wrench



SUBSEA TENSIONER

STUD TENSIONER - SST

Bolt coverage from 3/4" to 4"
only 8 tools, SST1 to SST8

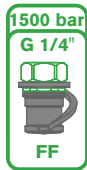

Patented Quick Reaction Nut

SST STUD TENSIONER

Quick Reaction Subsea Tensioner

Our Subsea stud tensioner incorporating the quick reaction nut feature reduces diver fatigue, improving diver safety and productivity.

- Visible piston stroke indication
- Positive 'over-stroke' stop to prevent piston expulsion/ seal damage.
- Piston/cylinder misalignment compensation
- Anti-slip cylinder surface for improved handling
- Low friction seals
- Anti-corrosion coating
- Bolt coverage from M20 to M100 (3/4" to 4")
- Designed to fit BS1560/ANSI B16.5/API flanges, as well as most compact flange designs

Made to Order, Consult Factory

Specifications and Dimensional Data

(Tool Reference)	Stud Diameter				Tool Load			Hydraulic Area		Approx. Wt.		Minimum Bolt Protrusion Above Nut				
	Load Cell Order No.	Metric	Quick Reaction Nut	3/4" to 4"	Ton	kN	Lbf	mm ²	in ²	kg	lb	Imp bolts		met bolts		
			Order No.	Imperial								Quick Reaction Nut Order No.	mm	in	mm	in
(SST1)	SSTAS010001	M20	QRNAS010004	3/4"	15.7	140	31,500	934	1.45	1.50	3.30	104	4.09	107	4.21	
		M22	QRNAS010005	7/8"								QRNAS010003	101	3.98	105	4.13
(SST2)	SSTAS020001	M24	QRNAS020004	1"	27	240	53,900	1,600	2.48	2.80	6.16	133	5.24	139	5.47	
		M27	QRNAS020005	1-1/8"								QRNAS020003	130	5.12	136	5.35
		M30	QRNAS020006	-								-	-	-	134	5.28
(SST3)	SSTAS030001	M33	QRNAS030005	1-1/4"	43	380	85,400	2,534	3.928	4	8.80	136	5.35	142	5.59	
		M36	QRNAS030006	1-3/8"								QRNAS030004	133	5.24	139	5.47
(SST4)	SSTAS040001	M39	QRNAS040005	1-1/2"	62	550	123,700	3,668	5.685	6	13.20	140	5.51	147	5.79	
		M42	QRNAS040006	1-5/8"								QRNAS040004	136	5.35	144	5.67
(SST5)	SSTAS050001	M45	QRNAS050005	1-3/4"	99	880	197,800	5,868	9.095	9	19.80	151	5.94	160	6.3	
		M48	QRNAS050006	1-7/8"								QRNAS050003	148	5.83	158	6.22
		M52	QRNAS050007	2"								QRNAS050004	145	5.71	154	6.06
(SST6)	SSTAS060001	M56	QRNAS060005	2-1/4"	175	1,560	351,000	10,411	16.137	14.7	32.34	166	6.54	178	7.01	
		M60	QRNAS060006	2-1/2"								QRNAS060003	160	6.30	175	6.89
		M64	QRNAS060007	2-3/4"								QRNAS060004	154	6.06	172	6.77
		M68	QRNAS060008	-								-	-	-	169	6.65
		M70	QRNAS060009	-								-	-	-	165	6.5
(SST7)	SSTAS070001	M76	QRNAS070005	3"	289	2,575	579,000	17,176	26.623	25	55	181	7.13	195	7.68	
		M80	QRNAS070006	3-1/4"								QRNAS070003	175	6.89	192	7.56
		M85	QRNAS070007	3-1/2"								QRNAS070004	169	6.65	188	7.40
		M90	QRNAS070008	-								-	-	-	184	7.24
(SST8)	SSTAS080001	M95	QRNAS080004	3-3/4"	388	3,447	775,300	22,997	35.645	39.1	86.02	205	8.07	224	8.82	
		M100	QRNAS080005	4"								QRNAS080003	199	7.83	220	8.66

In order to form a complete tensioner, order a load cell (SSTAS0#0001) and a Quick Reaction Nut (QRNAS0#00##).

Specifications and Dimensional Data

Piston stroke: 30mm (1.2") except for SST1 - 20mm (0.8")

Max tool pressure: 1,500 bar (21,750 psi)

Bolt protrusion above nut: refer to chart below for stud protrusion requirements

'D' includes an allowance for tool removal after bolt tightening with 30mm (1.2") tool stroke

Product development is constantly taking place and dimensions may change without notice

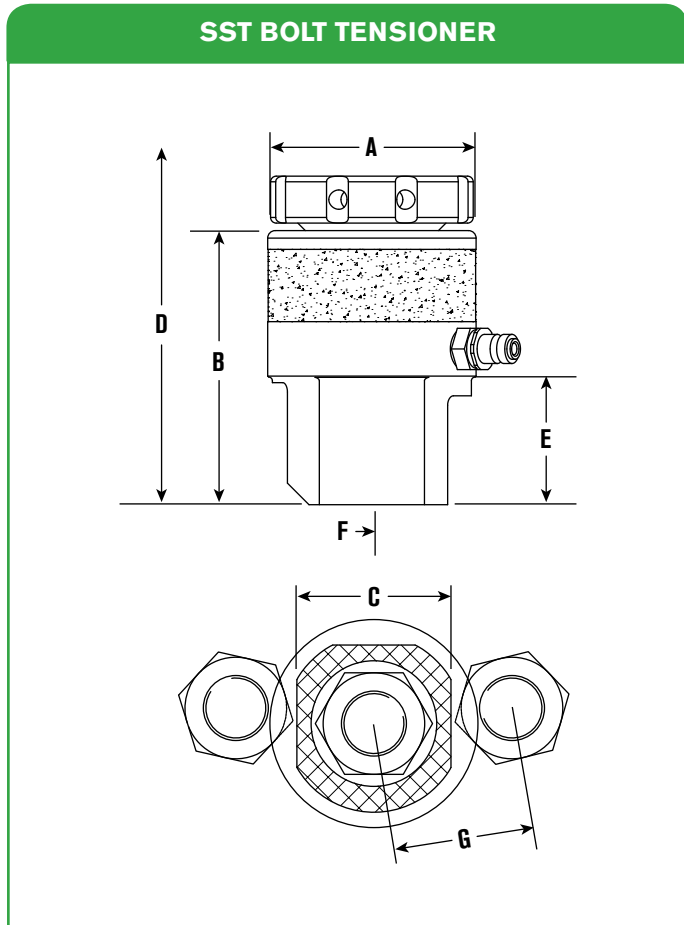

A		B		C		D				E		F		G				Stud Diameter		(Tool Reference)
mm	in	mm	in	mm	in	Imp bolts		met bolts		mm	in	mm	in	mm	in	mm	in	Metric	Imperial	Load Cell Order No.
66	2.6	97	3.8	48	1.9	228	9	228	9	40	1.6	19	0.7	44	1.7	44	1.7	M20	3/4"	(SST1)
														46	1.8	45	1.8	M22	7/8"	SSTAS010001
82	3.2	127.5	5	60	2.4	296	11.7	296	11.7	56.5	2.2	24.5	1	55	2.2	54	2.1	M24	1"	(SST2)
														58	2.3	56	2.2	M27	1-1/8"	SSTAS020001
														-	-	58	2.3	M30	-	
														69	2.7	68	2.7	M33	1-1/4"	(SST3)
97	3.8	137	5.4	77	3	309	12.2	309	12.2	63	2.5	28	1.1	72	2.8	71	2.8	M36	1-3/8"	SSTAS030001
														81	3.2	81	3.2	M39	1-1/2"	(SST4)
111	4.4	146	5.7	90	3.5	322	12.7	322	12.7	68	2.7	33.5	1.3	84	3.3	84	3.3	M42	1-5/8"	SSTAS040001
														98	3.9	98	3.9	M45	1-3/4"	(SST5)
136	5.4	158	6.2	114	4.5	342	13.5	342	13.5	77.5	3.1	40	1.6	101	4	101	4	M48	1-7/8"	SSTAS050001
														104	4.1	104	4.1	M52	2"	
														122	4.8	120	4.7	M56	2-1/4"	
														128	5	123	4.8	M60	2-1/2"	(SST6)
177	7	180.5	7.1	140	5.5	374	14.7	374	14.7	97	3.8	53	2.1	133	5.2	126	5	M64	2-3/4"	SSTAS060001
														-	-	129	5.1	M68	-	
														-	-	132	5.2	M70	-	
														159	6.3	155	6.1	M76	3"	
217	8.5	202	8	180	7.1	409	16.1	409	16.1	117.5	4.6	88	3.5	164	6.5	157	6.2	M80	3-1/4"	(SST7)
														170	6.7	160	6.3	M85	3-1/2"	SSTAS070001
														-	-	166	6.5	M90	-	
														190	7.5	184	7.2	M95	3-3/4"	(SST8)
248	9.8	230	9.1	210	8.3	480	18.9	480	18.9	128	5	85	3.3	196	7.7	190	7.5	M100	4"	SSTAS080001

FLANGE PULLERS

SUBSEA - SFP

700 bar/10,000 psi

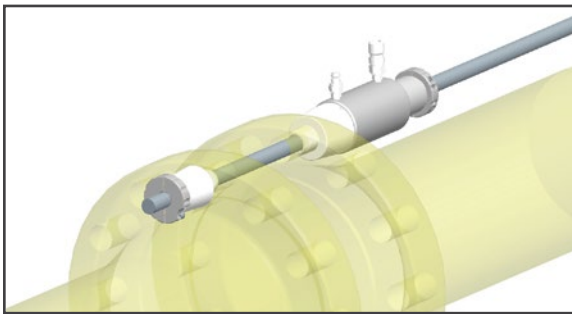
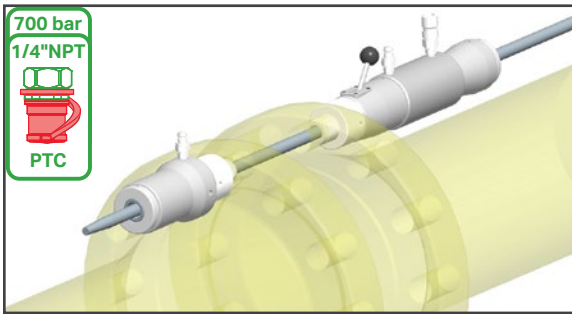

WIRE ROPE FLANGE PULLING SYSTEM

- Compact design
- Long Piston Stroke - 102mm (4")
- Self activating collet design
- Auto grab Anchor Collet with hydraulic release
- Manually releaseable Retract Collet prevents lock on
- High strength, low rotation wire rope
- Anti-Slip surfaces
- Operated via separate diver control valve providing precise control for up to 4 pullers

THREADED BAR FLANGE PULLING SYSTEM

- Compact design
- Long Piston Stroke - 102mm (4")
- 700 bar (10,000 psi) systems
- Rapid assembly using Quick Release Reaction Nuts
- High strength threaded bar
- Anti-Slip surfaces
- Operated via separate diver control valve providing precise control for up to 4 pullers

FEATURES

Compact Design

Designed to fit ANSI B16.5, MSS SP44, API 6A and most other flange applications dedicated flange hole adaptors.

Hydraulic Anchor Collet Release

Anchor collet automatically grips wire rope (without hydraulic pressure). Collets can be fully released by applying hydraulic pressure.

Auto Advance Collet Release

Advance collet fully disengages when the pulling cylinder is fully retracted

Manual Retract Collet Release

Retract collet can be manually disengaged, allowing the pulling cylinder (including Advance and Retrace collets) to be removed from the wire rope while the rope is installed in the flanges. Also allows the pulling system to be removed when pipe spring is evident (pipe spring makes the Anchor collet difficult to release).

Low Rotation Wire Rope

Special high load, 19mm and 22mm low rotation, steel wire rope ensure effective collet grip and reduces bird caging effects and strand unwinding.

Remote Diver Control Valve

Pulling Cylinders are controlled via a separate Valve Control Console allowing the diver to control the pullers remote from the work site. This eliminates bulky cylinder mounted control valves and negates constant diver intervention between pullers when advancing and retracting the cylinders.

Drawbar System Conversion with Quick Release Nuts

Pulling Cylinders can be simply converted to use a 1-1/8" threaded drawbar instead of wire ropes. The system utilizes Quick Release Reaction nuts for speed and versatility.

Flexible Design

Two or more cylinders can be linked together to cater for larger flange sizes/loads.

Specifications and Dimensional Data

Max capacity of cylinder: 199.3 kN (20.0 tonf)

Max operating pressure of cylinder: 700 bar (10,000 psi)

Max stroke of cylinder: 102 mm (4.0")

Diameter of wire ropes/drawbar available: 19.0mm, 22.0mm, 1-1/8" 8UN Drawbar

Specified minimum breaking load of rope: 19.0mm - 307 kN (30.8 tonf), 22mm - 415 kN (41.6 tonf)

System operating pressure with 19.0/22.0 mm rope: 345 bar (5,000 psi)

System operating pressure with 1-1/8" drawbar (Gr B7): 690 bar (10,000 psi)

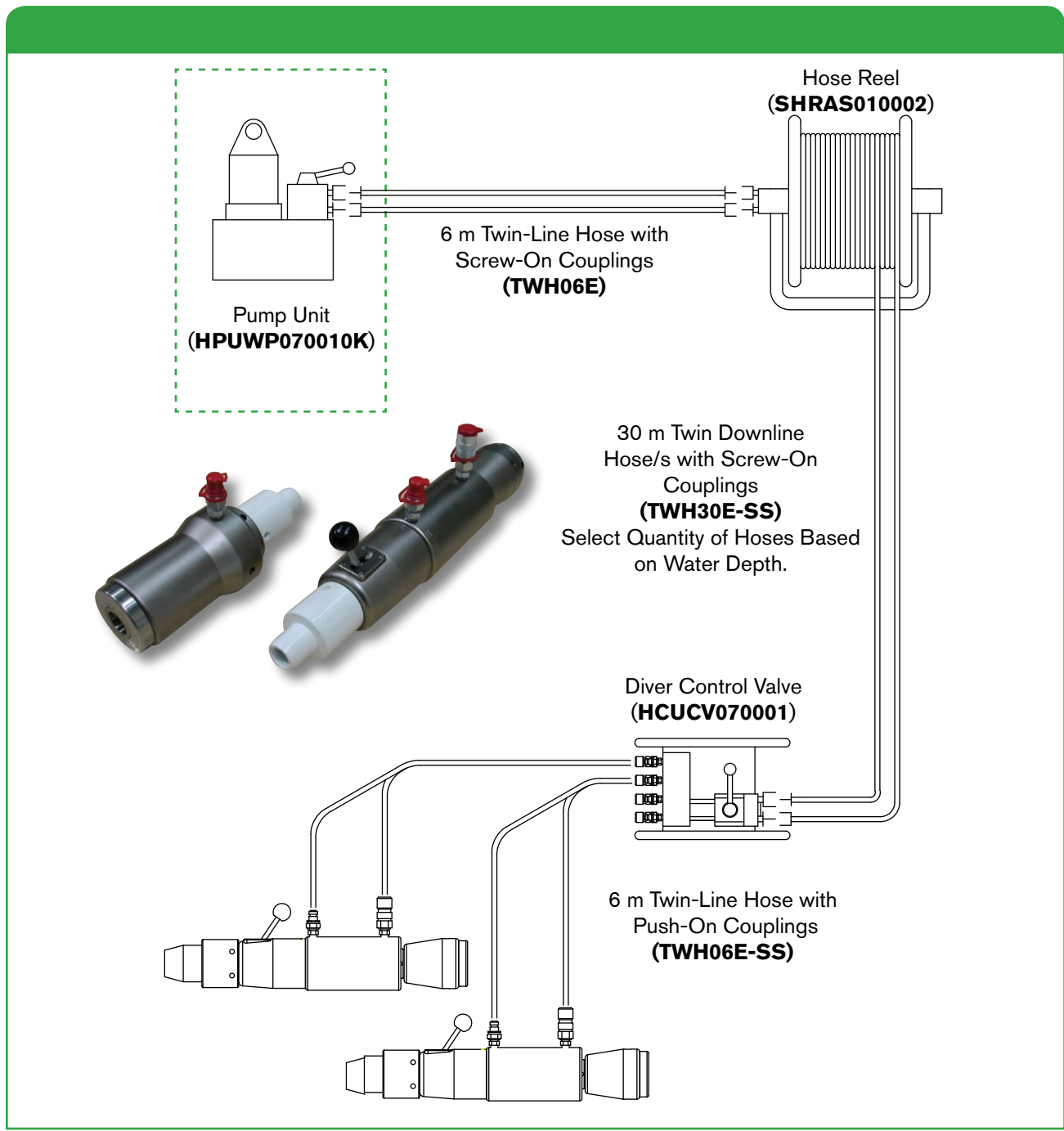

Specifications and Dimensional Data

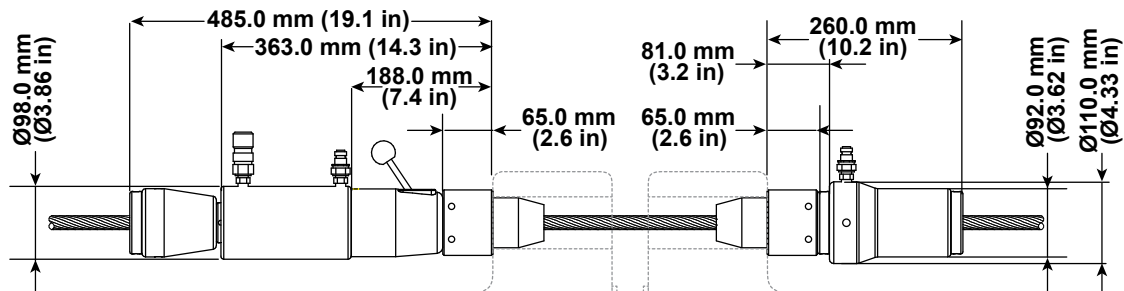
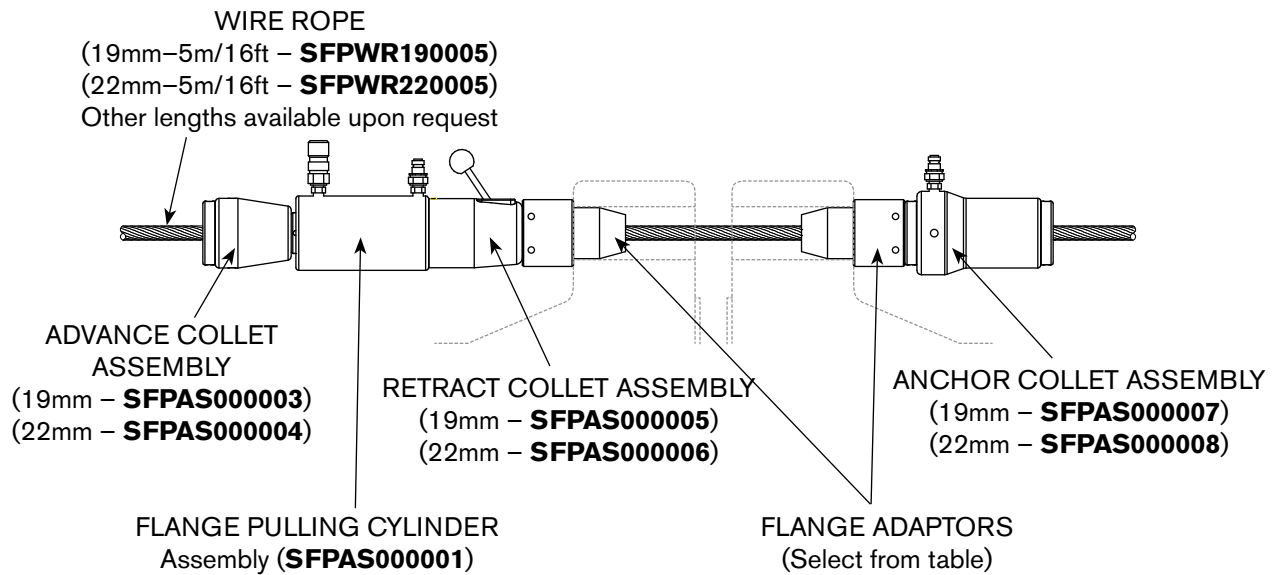

For Bolt Diameter		For Flange Hole Diameter		Wire Rope Flange Adapter Order No.
mm	in	mm	in	
M20	3/4	22.2	7/8	SFPWA000C00
M24	7/8	25.4	1	SFPWA000D00
M27	1	28.6	1-1/8	SFPWA000E00
M30	1-1/8	31.8	1-1/4	SFPWA000F00
M33	1-1/4	34.9	1-3/8	SFPWA000G00
M36	1-3/8	38.1	1-1/2	SFPWA000H00
M39	1-1/2	41.3	1-5/8	SFPWA000I00
M42	1-5/8	44.5	1-3/4	SFPWA000J00
M45	1-3/4	47.6	1-7/8	SFPWA000K00
M48	1-7/8	50.8	2	SFPWA000L00
M52	2	54	2-1/8	SFPWA000M00
M56	2-1/4	60.3	2-3/8	SFPWA000N00
M64	2-1/2	66.7	2-5/8	SFPWA000P00
M68/M70	2-3/4	73	2-7/8	SFPWA000Q00
M76	3	79.4	3-1/8	SFPWA000R00
M82	3-1/4	85.7	3-3/8	SFPWA000S00
M90	3-1/2	92.1	3-5/8	SFPWA000T00
M95	3-3/4	98.4	3-7/8	SFPWA000U00
M100	4	104.8	4-1/8	SFPWA000V00

THREADED BAR FLANGE PULLING SYSTEM

Specifications and Dimensional Data

1-1.8" 8UN THREADED DRAWBAR

(2m/6.5ft – **STDFA000167**)

Other lengths available upon request

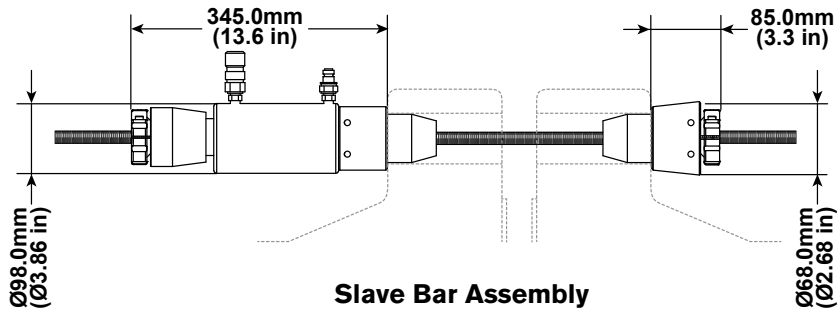
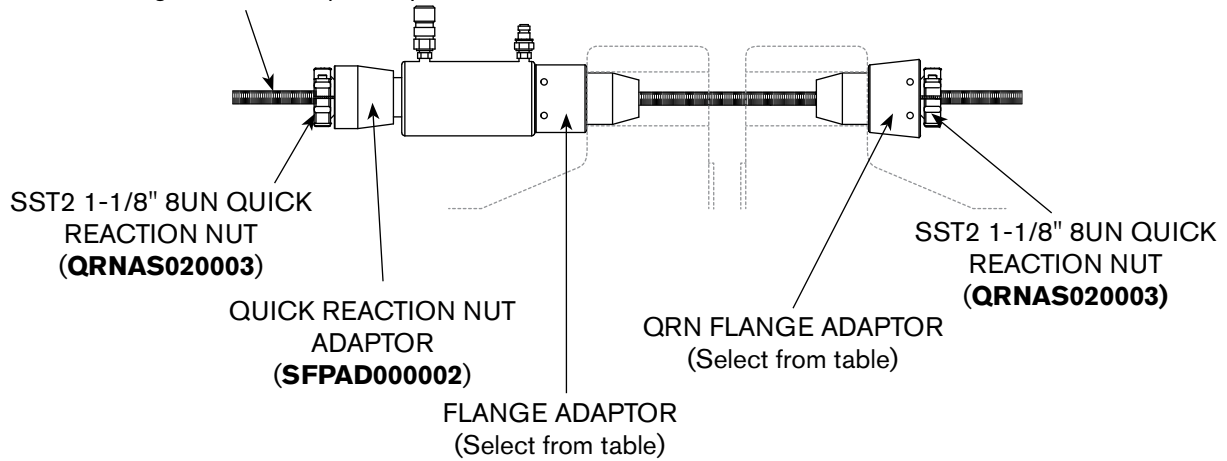

Slave Bar Assembly

1-1.8" 8UN THREADED DRAWBAR

(2m/6.5ft – **STDFA000167**)

Other lengths available upon request

SST2 1-1/8" 8UN QUICK REACTION NUT (**QRNAS020003**)

SLAVE BAR FLANGE ADAPTORS (Select from table)

SST2 1-1/8" 8UN QUICK REACTION NUT (**QRNAS020003**)

mm	For Bolt Diameter		For Flange Hole Diameter		Threaded Drawbar Flange Adaptor		Slave Bar Flange Adapter
	in	mm	in	Flange Adapter	QRN Flange Adapter		
M33	1-1/4	34.9	1-3/8	SFPTA000H00	SFPQA000H00	SFPSA000H00	
M36	1-3/8	38.1	1-1/2	SFPTA000I00	SFPQA000I00		
M39	1-1/2	41.3	1-5/8	SFPTA000J00	SFPQA000J00	SFPSA000K00	
M42	1-5/8	44.5	1-3/4	SFPTA000K00	SFPQA000K00		
M45	1-3/4	47.6	1-7/8	SFPTA000L00	SFPQA000L00	SFPSA000M00	
M48	1-7/8	50.8	2	SFPTA000M00	SFPQA000M00		
M52	2	54	2-1/8	SFPTA000N00	SFPQA000N00	SFPSA000Q00	
M56	2-1/4	60.3	2-3/8	SFPTA000P00	SFPQA000P00		
M64	2-1/2	66.7	2-5/8	SFPTA000Q00	SFPQA000Q00	SFPSA000T00	
M68/M70	2-3/4	73	2-7/8	SFPTA000R00	SFPQA000R00		
M76	3	79.4	3-1/8	SFPTA000S00	SFPQA000S00	SFPSA000U00	
M82	3-1/4	85.7	3-3/8	SFPTA000T00	SFPQA000T00		
M90	3-1/2	92.1	3-5/8	SFPTA000U00	SFPQA000U00	SFPSA000V00	
M95	3-3/4	98.4	3-7/8	SFPTA000V00	SFPQA000V00		
M100	4	104.8	4-1/8				

SUBSEA ACCESSORIES

HIGH FLOW PUMP

Typical use: Flange Pullers, Torque Wrenches, Nutsplitters

- Self priming, 2-speed operation
- 2.24 kw (3 hp) Air motor (50 CFM)
- 700 bar (10,000 psi) maximum pressure
- Calibratable 100mm (4") pressure gauge
- Adjustable pressure relief valve
- Flow rate up to 11.8 litres/min (720 cu. in/min)
- Internal oil cooler
- Low noise operation
- Pneumatic Filter/Regulator/Lubricator
- 9.5 Litre (2 gal.) Reservoir (optional oil level gauge)
- Carrying frame (WxLxH): 430 x 460 x 460 (mm)
- Weight: 40 Kg (88 lb) (inc. oil)
- Alternate Pump: PA60A can be used as an alternate to the **HPUWP070010K** shown. See page 74 for details.

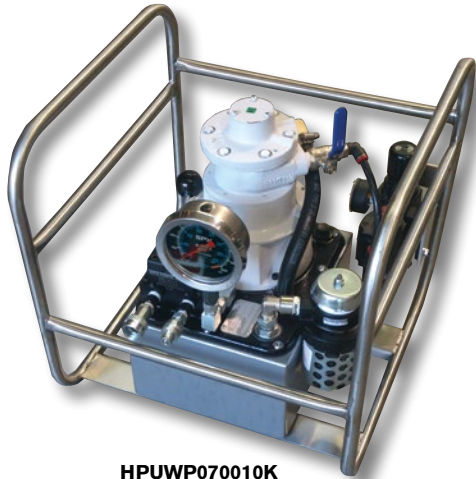

HPUWP070010K

SINGLE & TWIN-LINE HOSE REELS

- Hose reels available for tension and torque applications
- -30°C to 80°C working temperature range
- Female quick connect couplings as standard
- Hose Reel Dimensions (WxLxH): 750 x 1,000 x 1,050 (mm), 29" x 39" x 41"
- Hose Reel Weight: 65 Kg (145 lb) (without hose)



See page 102



REMOTE DIVER CONTROL VALVE

Gives diver precise control of Flange Pullers, Torque Wrenches, Nutsplitters, Jack, Cylinders, etc.

- 700 bar (10,000 psi) maximum working pressure
- Allows connection of up to 4 tools
- Stainless steel construction (rust free)
- Internal relief valve controls retract pressure
- Couplers on reel side are flat face for easy connection under water. Couplers on valve side match the required tool.
- Dimensions (WxLxH): 420 x 270 x 200 (mm)
- Weight: 9 kg (19.8 lb)



HCUCV070001



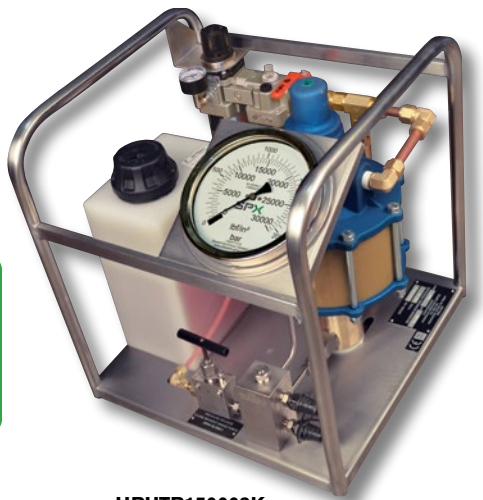

HPOTP150002K
See pages 94-97

HIGH FLOW BOLT-TENSIONING PUMP

Typical use: Subsea Bolt Tensioners, Segmented Tensioners

- 1,500 bar (21,750 psi) maximum working pressure (restricted)
- Calibrated 150mm (6") pressure gauge
- Flow rate up to 1.14 litres/min (70 cu. in/min)
- Dual oil outlets with quick-connect no spill couplings
- Pneumatic Filter/Regulator/Lubricator
- 9.5 Litre (2 gal.) polyethylene reservoir
- Dimensions (WxLxH): 465 x 530 x 515 (mm), 18" x 20" x 20"
- Approx. Weight: 23 Kg (51 lb)

OFFSHORE PUMP & HOSE ARRANGEMENT FOR SST SUBSEA TENSIONERS

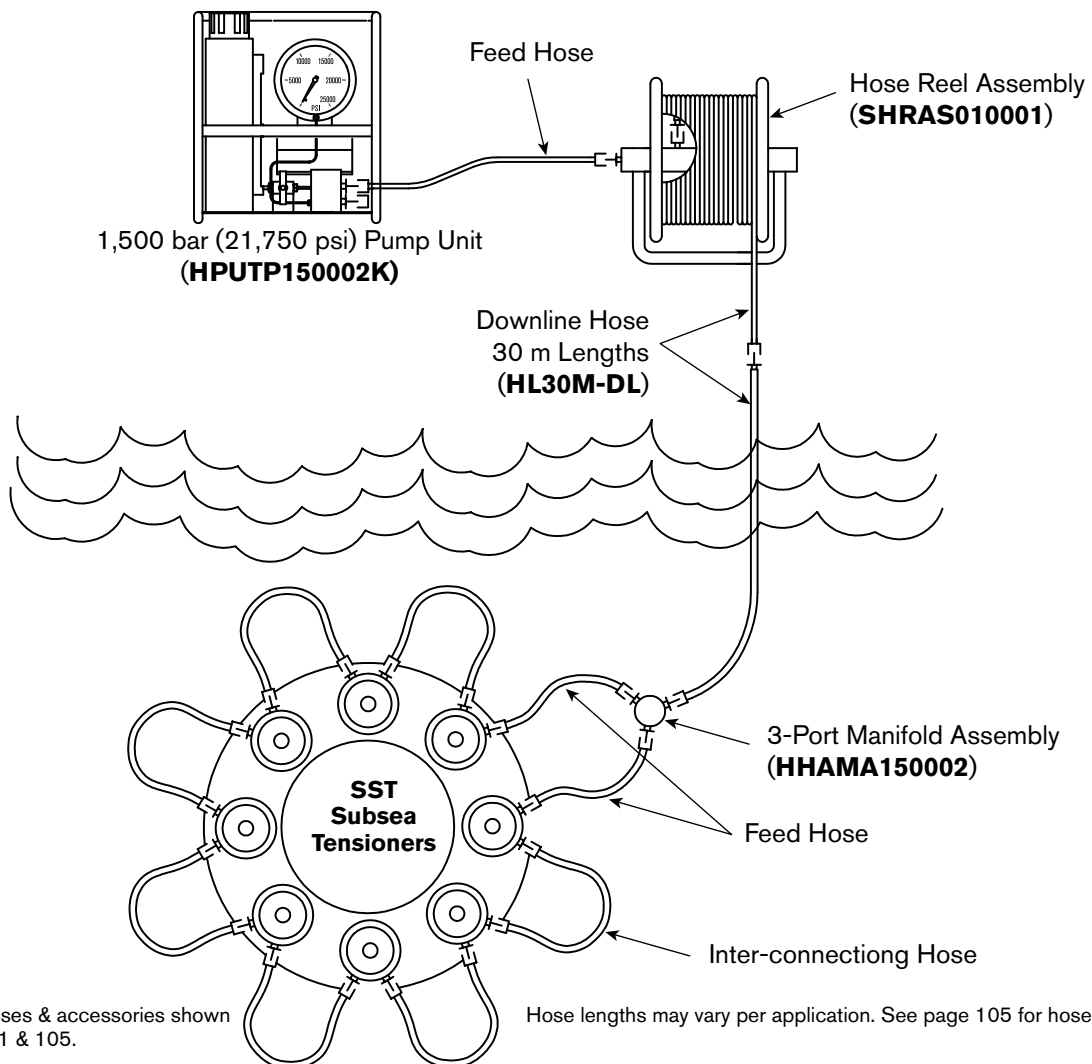

1,500 bar hoses & accessories shown on pages 101 & 105.

Hose lengths may vary per application. See page 105 for hose options.

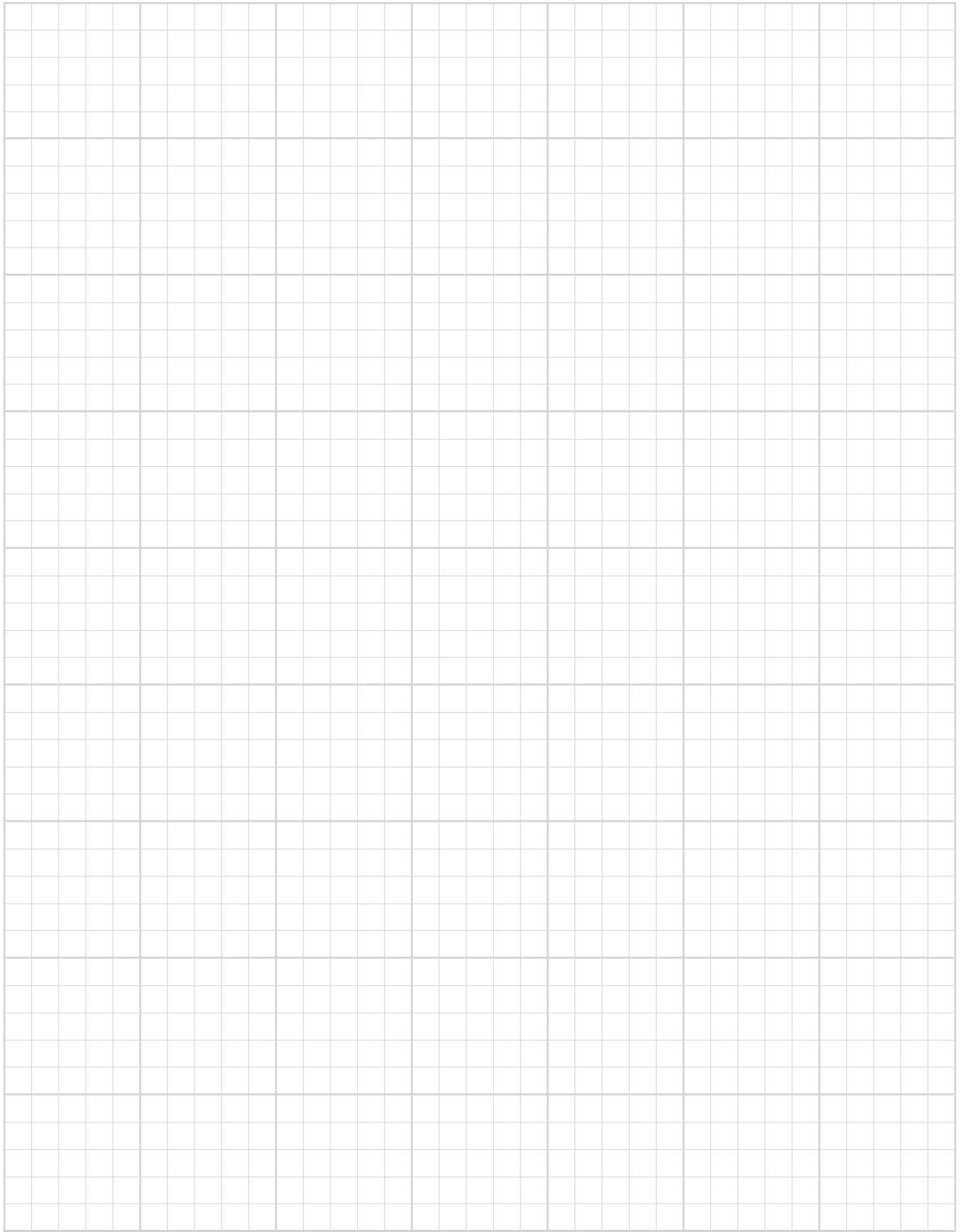

PUMPS

FOR TORQUE WRENCHES, NUT SPLITTERS & SPREADERS

700 BAR (10,000 PSI) - HIGH PERFORMANCE HYDRAULIC PUMPS

Page
**BOLTING PUMP
SUMMARY
CHART...70**

	Torque or Split										Tension	
	PE39	PE45	PE55	PE60	PE60A	PE60B	PE60C	PE60D	PE60E	PE60F		
US 1/2"	X	X	X	X	X	X	X	X	X	X	X	X
US 3/4"	X	X	X	X	X	X	X	X	X	X	X	X
1"	X	X	X	X	X	X	X	X	X	X	X	X
1 1/4"	X	X	X	X	X	X	X	X	X	X	X	X
1 1/2"	X	X	X	X	X	X	X	X	X	X	X	X
1 3/4"	X	X	X	X	X	X	X	X	X	X	X	X
2"	X	X	X	X	X	X	X	X	X	X	X	X
2 1/4"	X	X	X	X	X	X	X	X	X	X	X	X
2 1/2"	X	X	X	X	X	X	X	X	X	X	X	X
2 3/4"	X	X	X	X	X	X	X	X	X	X	X	X
3"	X	X	X	X	X	X	X	X	X	X	X	X
3 1/4"	X	X	X	X	X	X	X	X	X	X	X	X
3 1/2"	X	X	X	X	X	X	X	X	X	X	X	X
3 3/4"	X	X	X	X	X	X	X	X	X	X	X	X
4"	X	X	X	X	X	X	X	X	X	X	X	X
4 1/4"	X	X	X	X	X	X	X	X	X	X	X	X
4 1/2"	X	X	X	X	X	X	X	X	X	X	X	X
4 3/4"	X	X	X	X	X	X	X	X	X	X	X	X
5"	X	X	X	X	X	X	X	X	X	X	X	X
5 1/4"	X	X	X	X	X	X	X	X	X	X	X	X
5 1/2"	X	X	X	X	X	X	X	X	X	X	X	X
5 3/4"	X	X	X	X	X	X	X	X	X	X	X	X
6"	X	X	X	X	X	X	X	X	X	X	X	X
6 1/4"	X	X	X	X	X	X	X	X	X	X	X	X
6 1/2"	X	X	X	X	X	X	X	X	X	X	X	X
6 3/4"	X	X	X	X	X	X	X	X	X	X	X	X
7"	X	X	X	X	X	X	X	X	X	X	X	X
7 1/4"	X	X	X	X	X	X	X	X	X	X	X	X
7 1/2"	X	X	X	X	X	X	X	X	X	X	X	X
7 3/4"	X	X	X	X	X	X	X	X	X	X	X	X
8"	X	X	X	X	X	X	X	X	X	X	X	X
8 1/4"	X	X	X	X	X	X	X	X	X	X	X	X
8 1/2"	X	X	X	X	X	X	X	X	X	X	X	X
8 3/4"	X	X	X	X	X	X	X	X	X	X	X	X
9"	X	X	X	X	X	X	X	X	X	X	X	X
9 1/4"	X	X	X	X	X	X	X	X	X	X	X	X
9 1/2"	X	X	X	X	X	X	X	X	X	X	X	X
9 3/4"	X	X	X	X	X	X	X	X	X	X	X	X
10"	X	X	X	X	X	X	X	X	X	X	X	X
10 1/4"	X	X	X	X	X	X	X	X	X	X	X	X
10 1/2"	X	X	X	X	X	X	X	X	X	X	X	X
10 3/4"	X	X	X	X	X	X	X	X	X	X	X	X
11"	X	X	X	X	X	X	X	X	X	X	X	X
11 1/4"	X	X	X	X	X	X	X	X	X	X	X	X
11 1/2"	X	X	X	X	X	X	X	X	X	X	X	X
11 3/4"	X	X	X	X	X	X	X	X	X	X	X	X
12"	X	X	X	X	X	X	X	X	X	X	X	X
12 1/4"	X	X	X	X	X	X	X	X	X	X	X	X
12 1/2"	X	X	X	X	X	X	X	X	X	X	X	X
12 3/4"	X	X	X	X	X	X	X	X	X	X	X	X
13"	X	X	X	X	X	X	X	X	X	X	X	X
13 1/4"	X	X	X	X	X	X	X	X	X	X	X	X
13 1/2"	X	X	X	X	X	X	X	X	X	X	X	X
13 3/4"	X	X	X	X	X	X	X	X	X	X	X	X
14"	X	X	X	X	X	X	X	X	X	X	X	X
14 1/4"	X	X	X	X	X	X	X	X	X	X	X	X
14 1/2"	X	X	X	X	X	X	X	X	X	X	X	X
14 3/4"	X	X	X	X	X	X	X	X	X	X	X	X
15"	X	X	X	X	X	X	X	X	X	X	X	X
15 1/4"	X	X	X	X	X	X	X	X	X	X	X	X
15 1/2"	X	X	X	X	X	X	X	X	X	X	X	X
15 3/4"	X	X	X	X	X	X	X	X	X	X	X	X
16"	X	X	X	X	X	X	X	X	X	X	X	X
16 1/4"	X	X	X	X	X	X	X	X	X	X	X	X
16 1/2"	X	X	X	X	X	X	X	X	X	X	X	X
16 3/4"	X	X	X	X	X	X	X	X	X	X	X	X
17"	X	X	X	X	X	X	X	X	X	X	X	X
17 1/4"	X	X	X	X	X	X	X	X	X	X	X	X
17 1/2"	X	X	X	X	X	X	X	X	X	X	X	X
17 3/4"	X	X	X	X	X	X	X	X	X	X	X	X
18"	X	X	X	X	X	X	X	X	X	X	X	X
18 1/4"	X	X	X	X	X	X	X	X	X	X	X	X
18 1/2"	X	X	X	X	X	X	X	X	X	X	X	X
18 3/4"	X	X	X	X	X	X	X	X	X	X	X	X
19"	X	X	X	X	X	X	X	X	X	X	X	X
19 1/4"	X	X	X	X	X	X	X	X	X	X	X	X
19 1/2"	X	X	X	X	X	X	X	X	X	X	X	X
19 3/4"	X	X	X	X	X	X	X	X	X	X	X	X
20"	X	X	X	X	X	X	X	X	X	X	X	X
20 1/4"	X	X	X	X	X	X	X	X	X	X	X	X
20 1/2"	X	X	X	X	X	X	X	X	X	X	X	X
20 3/4"	X	X	X	X	X	X	X	X	X	X	X	X
21"	X	X	X	X	X	X	X	X	X	X	X	X
21 1/4"	X	X	X	X	X	X	X	X	X	X	X	X
21 1/2"	X	X	X	X	X	X	X	X	X	X	X	X
21 3/4"	X	X	X	X	X	X	X	X	X	X	X	X
22"	X	X	X	X	X	X	X	X	X	X	X	X
22 1/4"	X	X	X	X	X	X	X	X	X	X	X	X
22 1/2"	X	X	X	X	X	X	X	X	X	X	X	X
22 3/4"	X	X	X	X	X	X	X	X	X	X	X	X
23"	X	X	X	X	X	X	X	X	X	X	X	X
23 1/4"	X	X	X	X	X	X	X	X	X	X	X	X
23 1/2"	X	X	X	X	X	X	X	X	X	X	X	X
23 3/4"	X	X	X	X	X	X	X	X	X	X	X	X
24"	X	X	X	X	X	X	X	X	X	X	X	X
24 1/4"	X	X	X	X	X	X	X	X	X	X	X	X
24 1/2"	X	X	X	X	X	X	X	X	X	X	X	X
24 3/4"	X	X	X	X	X	X	X	X	X	X	X	X
25"	X	X	X	X	X	X	X	X	X	X	X	X
25 1/4"	X	X	X	X	X	X	X	X	X	X	X	X
25 1/2"	X	X	X	X	X	X	X	X	X	X	X	X
25 3/4"	X	X	X	X	X	X	X	X	X	X	X	X
26"	X	X	X	X	X	X	X	X	X	X	X	X
26 1/4"	X	X	X	X	X	X	X	X	X	X	X	X
26 1/2"	X	X	X	X	X	X	X	X	X	X	X	X
26 3/4"	X	X	X	X	X	X	X	X	X	X	X	X
27"	X	X	X	X	X	X	X	X	X	X	X	X
27 1/4"	X	X	X	X	X	X	X	X	X	X	X	X
27 1/2"	X	X	X	X	X	X	X	X	X	X	X	X
27 3/4"	X	X	X	X	X	X	X	X	X	X	X	X
28"	X	X	X	X	X	X	X	X	X	X	X	X
28 1/4"	X	X	X	X	X	X	X	X	X	X	X	X
28 1/2"	X	X	X	X	X	X	X	X	X	X	X	X
28 3/4"	X	X	X	X	X	X	X	X	X	X	X	X
29"	X	X	X	X	X	X	X	X	X	X	X	X
29 1/4"	X	X	X	X	X	X	X	X	X	X	X	X
29 1/2"	X	X	X	X	X	X	X	X	X	X	X	X
29 3/4"	X	X	X	X	X	X	X	X	X	X	X	X
30"	X	X	X	X	X	X	X	X	X	X	X	X
30 1/4"	X	X	X	X	X	X	X	X	X	X	X	X
30 1/2"	X	X	X	X	X	X	X	X	X	X	X	X
30 3/4"	X	X	X	X	X	X	X	X	X	X	X	X
31"	X	X	X	X	X	X	X	X	X	X	X	X
31 1/4"	X	X	X	X	X	X	X	X	X	X	X	X
31 1/2"	X	X	X	X	X	X	X	X	X	X	X	X
31 3/4"	X	X	X	X	X	X	X	X	X	X	X	X
32"	X	X	X	X	X	X	X	X	X	X	X	X
32 1/4"	X	X	X	X	X	X	X	X	X	X	X	X
32 1/2"	X	X	X	X	X	X	X	X	X	X	X	X
32 3/4"	X	X	X	X	X	X	X	X	X	X	X	X
33"	X	X	X	X	X	X	X	X	X	X	X	X
33 1/4"	X	X	X	X	X	X	X	X	X	X	X	X
33 1/2"	X	X	X	X	X	X	X	X	X	X	X	X
33 3/4"	X	X	X	X								

BOLTING PUMP SUMMARY CHART

Most customers choose to use hand pumps for spreading and nutsplitting applications because of their ability to spread and hold. When using spreaders with torque wrench pumps, use only the top port advance and know that the spreader will retract when the pump is turned off.

Bold Products have higher stocking levels. X

		Torque or Split							Tension				
		PE39	PE45	PE55TWP-BS	X1E#-PT	PG120TWP	PA60A	RWP55-BS	RWP55-Dual	X1A1-PT	PE8	HPUTP-1	HPUTP-2
POWER SOURCE	ELECTRIC (110/115V)	X	X	X	X						X		
	ELECTRIC (220/230V)	X	X	X	X						X		
	AIR						X	X	X	X		X	X
	GAS					X							
ELECTRIC MOTOR TYPE	UNIVERSAL	X	X	X	X	n/a					X		
	INDUCTION					n/a							
MAX PRESSURE	10,000 PSI (700 BAR)	X	X	X	X	X	X	X	X	X			
	21,750 PSI (1,500 BAR)										X	X	X
PUMP TYPE	TWO-STAGE	X		X	X		X	X	X	X	X		
	INFINITE STAGE (ISP)		X				X						
FLOW RATE @MAX PRESSURE	LOW (<20 IN ³ /MIN, <0.33 L/min)										X		
	MED. (<40 IN ³ /MIN, <0.66 L/min)	X											
	HIGH (<60 IN ³ /MIN, <0.98 L/min)		X	X	X		X	X		X		X	
	VERY HIGH (>60 IN ³ /MIN, >0.98 L/min)					X			X				X
SPEED @MAX PRESSURE	SLOW	X									X		
	MED			X	X			X		X		X	
	FAST		X			X	X		X				X
APPLICATION TYPE	ORIGINAL INSTALL		X	X	X	X	X	X	X	X	X	X	X
	OPERATIONS/MRO/SERVICE	X		X	X			X		X	X	X	X
DUTY CYCLE	CONTINUOUS		X	X	X	X	X	X	X	X	X	X	X
	INTERMITTENT	X		X	X			X		X	X	X	X
# OF PORTS (TOOL QUANTITY)	1	X	X	X	X	X	X	X	X	X			
	2										X	X	X
	4		X	X			X	X	X				
OIL TANK CAPACITY	0.5 GAL (1.9 L)	X											
	1.0 GAL (3.8 L)										X		
	1.25 GAL (4.7 L)												
	1.5 GAL (5.7 L)		X										
	2.0 GAL (7.6 L)						X						
	2.5 GAL (9.4 L)			X	X			X		X		X	X
	3.0 Gal (11.3 L)					X							
5.0 GAL (18.9 L)								X					
SPECIAL CONSIDERATIONS/ LOCATIONS/ APPLICATIONS *	SUBSEA (UNDERWATER)												X
	WIND/UP-TOWER, TIGHT SPACE	X									X		
	WIND/FOUNDATION TENSION										X	X	X
	ATEX (Ex) II 2 GDc T4						X						
	CE	X	X			X	X				X	X	X
	AUTO CYCLE		X										
	PENDANT INCLUDED	X	X	X	X	X	X	X	X	X	X		
	OPTIONAL COOLER AVAILABLE	X	X					X					

Virtually any pump may be used for Original Installation or Service. This chart factors pump cost and usage together to determine a total cost of ownership and recommends a pump based upon value delivered.

* Please contact factory of authorized reseller with questions about special applications.

Pumps designed for torque wrench applications do not hold pressure, they should NOT be used for lifting applications and should be used with caution for spreading applications.

The Infinity Stage Pump (ISP) from SPX FLOW helps get work done faster. The innovative, patent pending design takes advantage of a continuously variable output that provides maximum flow within the rated pressure range of the pump - from 0 - 700 bar (0 to 10,000 psi). Most torquing and spreading work is done between 70 – 400 bar (1,000 – 6,000 psi), which is where the Infinity Stage Pumps (ISP) provide the most significant advantage over traditional pumps. For example, at 70 bar (1,000 psi) there is 5X as much flow as a traditional two-stage pump. At 275 bar (4,000 psi) there is 2X as much flow as a traditional pump.

THE ISP ADVANTAGE: INCREASED PRODUCTIVITY

The additional flow moves tools faster which allows work to be done quicker and more efficiently. The increased efficiency saves you time – allowing you to get onto your next job sooner and more profitably.

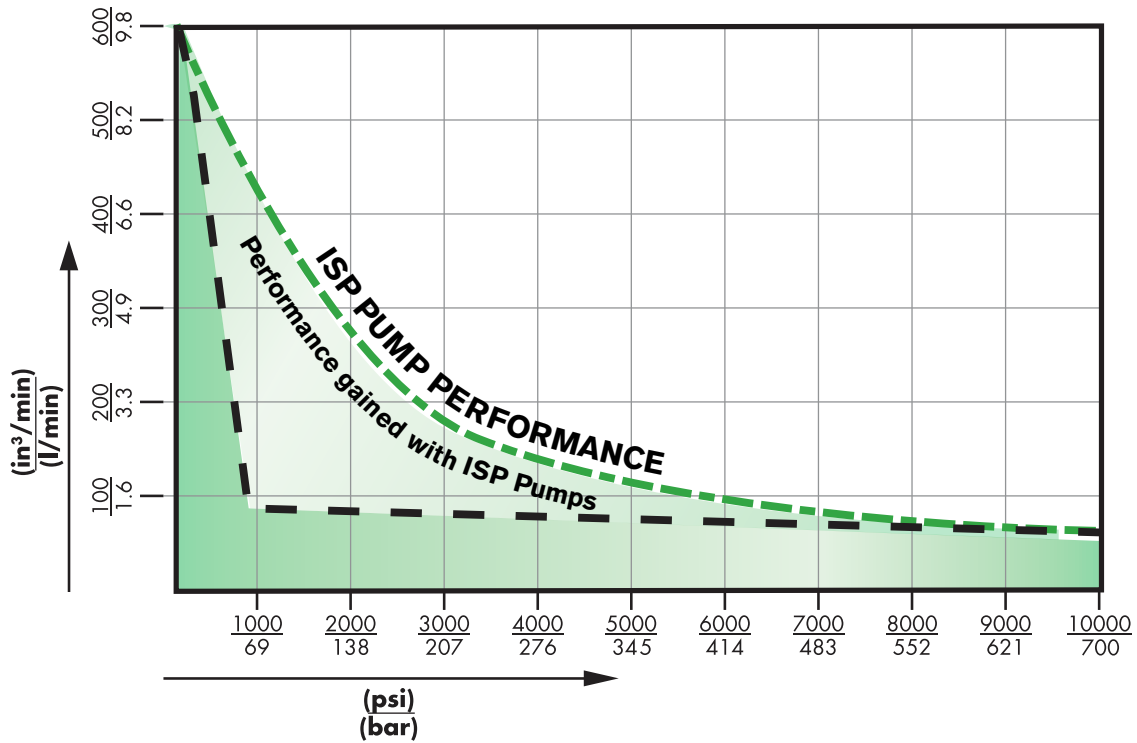

FEATURED ON

PE45



PA60A



INFINITY SERIES ELECTRIC PUMP

PE45
700 bar/10,000 psi



700 BAR (10,000 PSI) INFINITY SERIES (ISP) ELECTRIC PUMP

The PE45 is an Infinite Stage Electric Pump which increases productivity on the job by providing continuous pressure for up to 2x the speed of typical 2-stage pumps. Jobs get done faster and easier.

Quality means Lower Life-Cycle Costs:

- Over 100,000 cycles
- Continuous duty up to 50°C (122°F) ambient
- Proven design = Proven reliability

Enhanced Usability:

- Light Weight: 32.2 kg (71 lb) [without oil]
- Removable control pendant (5 m/15 ft)
- Removable 100mm (4"), calibration-capable gauge
- Universal Motor for reduced voltage applications (up to -20% nominal voltage)
- 4 tool manifold available powers up to 4 tools from a single pump (not for lifting applications)
- High flow to get work done faster

Designed with Safety in Mind:

- Easily adjusted pressure regulator (relief) valve
- Fixed 103 bar (1,500 psi) retract relief valve pressure

DESIGNED FOR

Electric



Air



Gas



Hand



MAINTENANCE
& REPAIR

ORIGINAL
INSTALL

Split



Tension



Torque



Max
Flow



Specifications and Dimensional Data

Size (L x W x H): 45 cm x 35.6 cm x 67.5 cm
17.7" x 14.0" x 26.6"

Weight: 32.2 kg (71 lb) [without oil]

Maximum Oil Capacity: (vented reservoir)
6.75 L (1.5 Gallons) [to fill line]
5.1 L (1.12 Gallons) [usable]

Operating Environment:
-25°C to +50°C (-13°F to +122°F)

(When operating near temperature extremes, it is recommended to use hydraulic oils that are rated for those temperatures. Refer to service manual and cooling option)

Sound Level: 87-92 dBA (max)

Pressure: 0 - 700 bar (0 - 10,000 psi)

Typical Flow: 9.4 L/min - 0.8 L/min
(575 in³/min - 48 in³/min)

Power: 1.8 hp Universal Motor
110/115V - 50/60 Hz (17 amps)
220/230V - 50/60 Hz (8.5 amps)

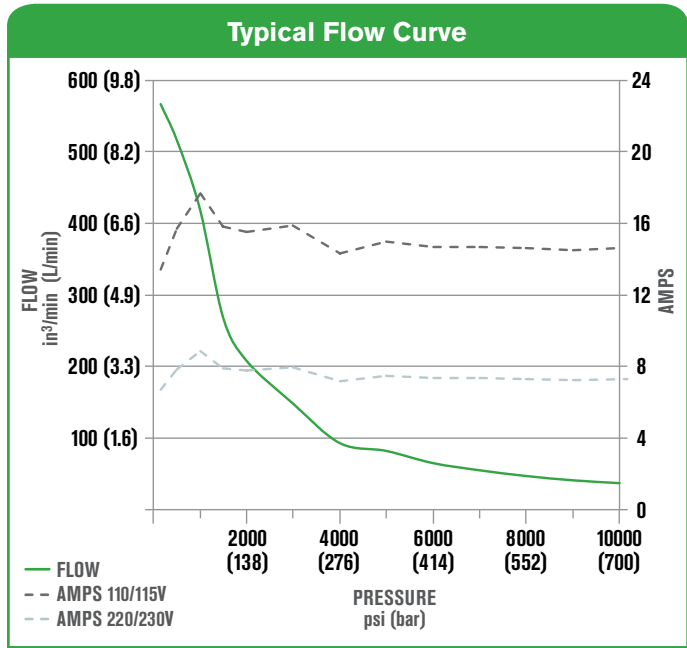

OPTIONS:

- Roll Cage
- 4-Port manifold
- 115V grounded plug pre-installed

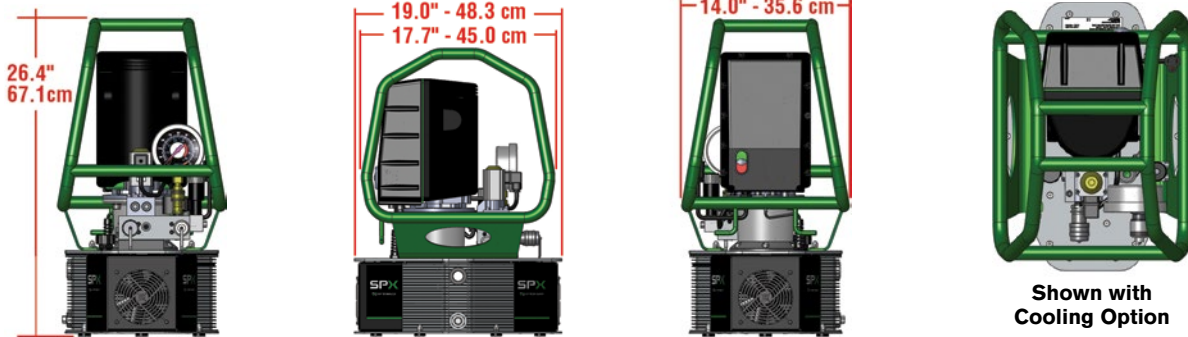

Ordering Information

PE 45 **EE 4** **PRS**

Power Source

- Y** = 110/115 VAC w/plug
- L** = 110/115 VAC w/flying leads (not stocked)
- P** = 220/230 VAC w/flying leads

Auto Cycle

- Blank** = No Auto Cycle
- A** = w/Auto Cycle

- Ports

- Blank** = 1 port (1 tool)
- M** = 4 ports (4 tools)

Example: PE45YEE4AMPRS

PE45 Electric Pump with 110/115 VAC Motor with cord with typical grounded 3 prong plug, with Auto Cycle Feature, and with 4 ports.

INFINITY SERIES AIR PUMP

PA60A

700 bar/10,000 psi



700 BAR (10,000 PSI) INFINITY SERIES (ISP) AIR PUMP

The PA60A is an Infinity Stage Air Pump which increases productivity on the job by providing continuous pressure for up to 2x the speed of typical 2-stage pumps. Jobs get done faster and easier.

Quality means Lower Life-Cycle Costs:

- Over 100,000 cycles
- Continuous duty up to 50°C (122°F) ambient
- Proven design = Proven reliability

Enhanced Usability:

- Light weight and portable: 34.9 kg (77 lb) [without oil] PA60APF5FP
- Light weight and portable: 40.1 kg (88 lb) [without oil] PA60APF5FMPR
- Removable control pendant (7.6 m/ 25 ft)
- Removable 100 mm (4"), calibration-capable gauge
- CE
- ATEX Ex II 2 GDc T4
- 4 port manifold available to power up to 4 tools from a single pump (not for lifting applications)
- Fewer parts for lower service cost

Designed with Safety in Mind:

- Easily adjusted pressure regulator (relief) valve
- Fixed 103 bar (1,500 psi) retract relief valve pressure

DESIGNED FOR

Electric



Air



Gas



Hand



MAINTENANCE
& REPAIR

ORIGINAL
INSTALL

Split



Tension



Torque



Max
Flow



Specifications and Dimensional Data

Size (L x W x H): 50 cm x 36 cm x 51 cm
19.6" x 14.0" x 20.2" (PA60APF5FMP)

Size (L x W x H): 47 cm x 30 cm x 53 cm
18.6" x 11.8" x 21.0" (PA60APF5FMPR)

Weight:

34.9 kg (76.9 lb) [without oil] PA60APF5FP
36.9 kg (81.5 lb) [without oil] PA60APF5FMP
37.9 kg (83.7 lb) [without oil] PA60APF5FPR
40.0 kg (88.3 lb) [without oil] PA60APF5FMPR

Maximum Oil Capacity: (vented reservoir)

8.5 L (2.2 Gallons) [to fill line]
7.0 L (1.8 Gallons) [usable]

Operating Environment:

-25°C to +50°C (-13°F to +122°F)

(When operating near temperature extremes, it is recommended to use hydraulic oils that are rated for those temperatures. Refer to service manuals and cooling options)

Sound Level: 76 dBA (max)

Pressure: 0 - 700 bar (0 - 10,000 psi)

Typical Flow: 9.4 L/min - 0.8 L/min
(575 in³/min - 48 in³/min)

Air: 2.3 m³/min @ 5.5 bar (80 cfm @ 80 psi)
2.5 m³/min @ 6.2 bar (90 cfm @ 90 psi)
2.8 m³/min @ 6.9 bar (100 cfm @ 100 psi)

* Values shown are with filter/regulator/lubricator.
Values will increase without filter/regulator/
lubricator.

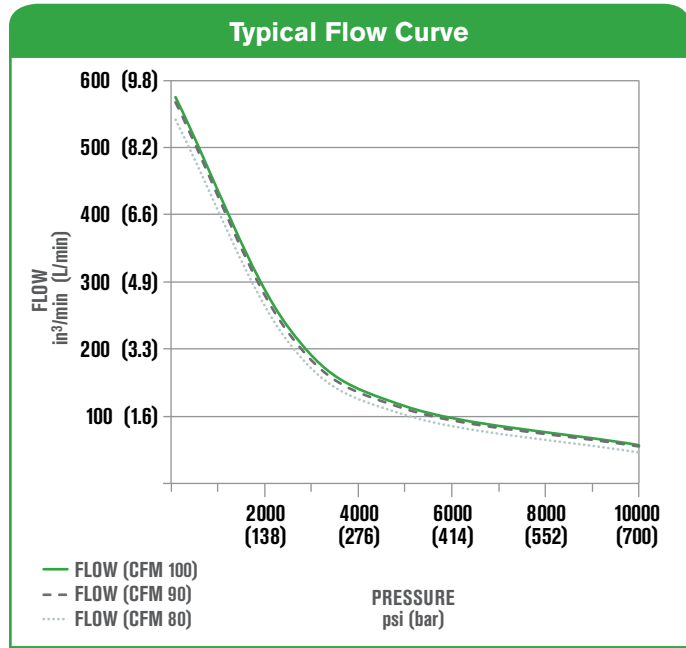

Hydraulic Oil Delivery

	@ 100 cfm	@ 90 cfm	@ 80 cfm
750 psi 51 bar	9.4 L/min (575 in ³ /min)	9.3 L/min (567 in ³ /min)	8.9 L/min (541 in ³ /min)
2,500 psi 175 bar	3.8 L/min (233 in ³ /min)	3.7 L/min (225 in ³ /min)	3.4 L/min (211 in ³ /min)
5,000 psi 350 bar	1.9 L/min (115 in ³ /min)	1.8 L/min (111 in ³ /min)	1.7 L/min (102 in ³ /min)
10,000 psi 700 bar	0.9 L/min (57 in ³ /min)	0.9 L/min (55 in ³ /min)	0.8 L/min (46 in ³ /min)

Ordering Information

Order No.	Description
PA60APF5FMP	PUMP, ISP 60 CU-IN/MIN, AIR/HYD, 4-PORT
PA60APF5FMPR	PUMP, ISP 60 CU-IN/MIN, AIR/HYD 4-PORT, Roll Cage
PA60APF5FP	PUMP, ISP 60 CU-IN/MIN, AIR/HYD
PA60APF5FPR	PUMP, ISP 60 CU-IN/MIN, AIR/HYD, Roll Cage

COMPACT ELECTRIC TORQUE WRENCH PUMP

PE39

700 bar/10,000 psi



700 BAR (10,000 PSI) COMPACT ELECTRIC TORQUE WRENCH PUMP

The PE39 is compact and capable of being used in a vertical or horizontal orientation. Based on proven pump design for reliability in rugged torque wrench applications to support operation and maintenance requirements.

Quality means Lower Life-Cycle Costs:

- Over 100,000 cycles
- Continuous duty up to 50°C (122°F) ambient
- Proven design = proven reliability

Enhanced Usability:

- Light weight and portable: 17.7 kg (39 lb)
- Removable control pendant (5 m/15 ft cord length)
- Removable 100 mm (4") calibration-capable gauge
- Universal Motor for reduced voltage applications (up to -20% nominal voltage)
- Vertical or horizontal operation
- Easy install cooling fan as option

Designed with Safety in Mind:

- Easily adjusted pressure regulator (relief) valve
- Fixed 103 bar (1,500 psi) retract relief valve pressure

DESIGNED FOR

Electric



Air



Gas



Hand



MAINTENANCE & REPAIR

ORIGINAL INSTALL

Split



Tension



Torque



Max Flow



To be used with torque wrenches, pages 10-31

Specifications and Dimensional Data

Size (L x W x H): 35 cm x 27.4 cm x 60 cm
13.8" x 10.8" x 23.7"

Weight: 17.7 kg (39 lb) [without Oil]

Maximum Oil Capacity: (non-vented reservoir)
1.9 L (0.5 Gallons) [to fill line]
1.5 L (0.4 Gallons) [usable]

Operating Environment: -25°C to +50°C
(-13°F to +122°F)

(When operating near temperature extremes, it is recommended to use hydraulic oils that are rated for those temperatures. Refer to service manuals and cooling options)

Sound Level: 87 – 92 dBA (max)

Pressure: 0 - 700 bar (0 - 10,000 psi)

Typical Flow: 3.7 L/min - 0.64 L/min
(225 in³/min - 39 in³/min)

Power: 1.3 hp Universal Motor
110/115V - 50/60 Hz (14.5 amps)
220/230V - 50/60 Hz (7.2 amps)



Typical Flow Curve

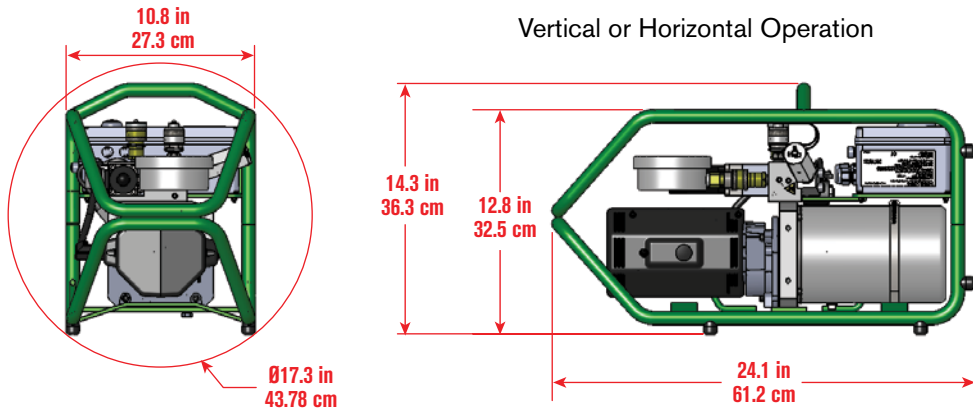
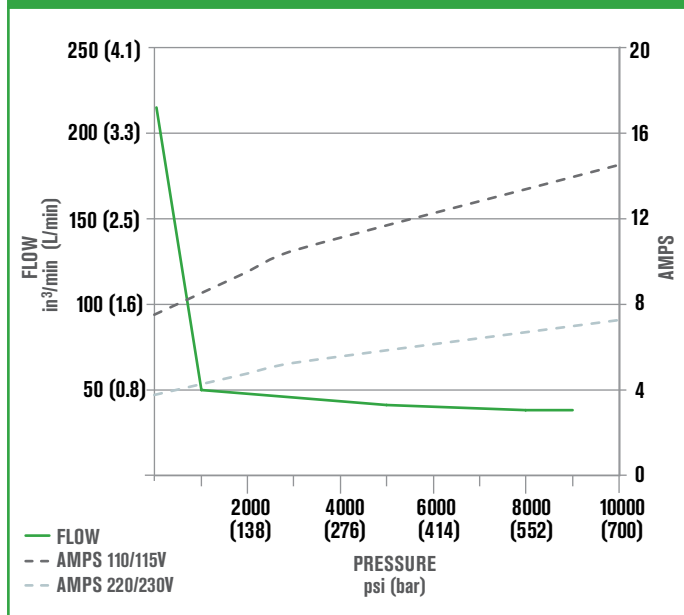

Ordering Information

Order No.	Description
PE39YED1PR	110/115VAC
PE39YED1BPR	110/115VAC with cooling option
PE39PED1PR	220/230VAC
PE39PED1BPR	220/230VAC with cooling option

OPTIONS

- Auxiliary Cooling Fan (Field Installable)
Order No. 3000610

CLASSIC SERIES ELECTRIC HYDRAULIC PUMP

PE55TWP-BS
700 bar/10,000 psi



700 BAR (10,000 PSI) CLASSIC SERIES ELECTRIC HYDRAULIC PUMP

The PE55TWP-BS has been the market leading electric pump for over 30 years & is therefore tried & tested. A simple, light-weight design with a recent upgrade that has created a cost-effective workhorse.

Quality means Lower Life-Cycle Costs:

- Over 100,000 cycles
- Continuous duty up to 50°C (122°F) ambient
- Proven design = Proven reliability

Enhanced Usability:

- Two Speed High Performance pump
- Retract side internal relief valve protects tool
- Hand remote
- Four-tool manifold (-4 models only) allow use of up to four tools simultaneously
- 4" calibration capable gauge
- Use with single or double acting tools

Designed with Safety in Mind:

- Easily adjusted pressure regulator (relief) valve
- 103 bar (1,500 psi) pressure retract relief valve

DESIGNED FOR

Electric



Air



Gas



Hand



MAINTENANCE
& REPAIR

ORIGINAL
INSTALL

Split



Tension



Torque



Max
Flow



Specifications and Dimensional Data

Size (L x W x H): 147 cm x 24 cm x 49 cm
18.5" x 9.5" x 19.2"

Weight: 29.5 kg (65 lb) [without oil]

Maximum Oil Capacity: (vented reservoir)
6.8 L (1.8 Gallons) [to fill line]
5.3 L (1.4 Gallons) [usable]

Operating Environment: -25°C to +50°C
(-13°F to +122°F)

(When operating near temperature extremes, it is recommended to use hydraulic oils that are rated for those temperatures. Refer to service manuals and cooling options)

Sound Level: 87-92 dBA (max)

Pressure: 0 - 700 bar (0 - 10,000 psi)

Typical Flow: 11.5 L/min - 0.9 L/min
(704 in³/min - 56 in³/min)

Power: 1-1/8 hp Universal Motor
110/115V - 50/60 Hz (25 amps)
220/230V - 50/60 Hz (13 amps)

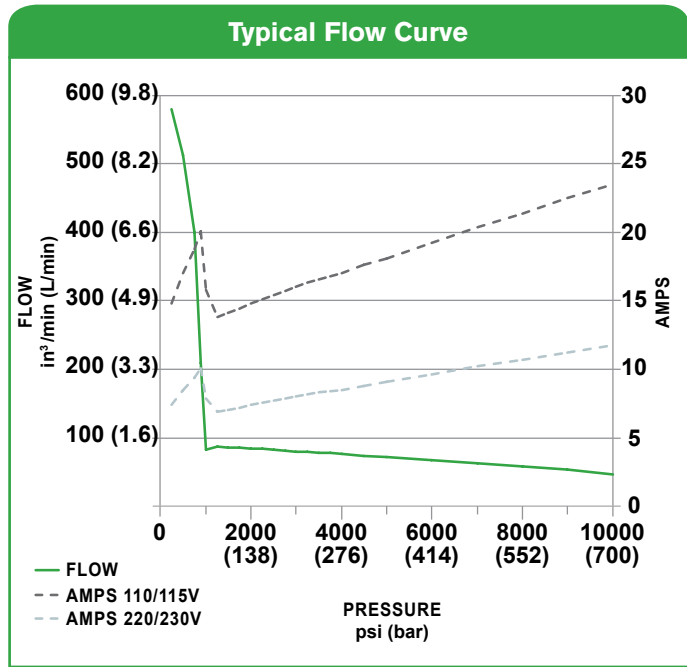

Order No.	Oil Delivery	Oil Reservoir	Usable Oil	Overall Width	Overall Length	Overall Height	Pump Weight w/Oil
	per min.	L (gal)	L (in ³)	mm (in)	mm (in)	mm (in)	kg (lb)
PE55TWP-BS PE55TWP-220-BS	11.5 L/min @ 6.9 bar 704 in ³ @ 100 psi	9.5 (2.5)	5.4 (324)	435 (17.14)	241 (9.5)	460 (18.12)	34 (75)
	0.9 L/min @ 700 bar 56 in ³ @ 10,000 psi						
PE55TWP-4-BS PE55TWP-4-CF-BS PE55TWP-4-220-BS	11.5 L/min @ 6.9 bar 704 in ³ @ 100 psi	9.5 (2.5)	5.4 (324)	470 (18.49)	241 (9.5)	487 (19.15)	35.5 (78)
	0.9 L/min @ 700 bar 56 in ³ @ 10,000 psi						

Electrical Data

	Electric Motor	Electrical Control
PE55TWP-BS PE55TWP-4-BS PE55TWP-4-CF-BS	1-1/8 hp, 12000 rpm 110/150V, 50/60Hz, 25 amps	Remote control with 20-foot cord
PE55TWP-220-BS PE55TWP-4-220-BS	1-1/8 hp, 12000 rpm 220/230V, 50/60Hz, 13 amps	

Ordering Information

Order No.	Description
PE55TWP-BS	110/115V, 50/60 Hz, Single Tool
PE55TWP-4-BS	110/115V, 50/60 Hz, 4 Tool
PE55TWP-4-CF-BS	110/115V, 50/60 Hz, 4 Tool, with Cooling Fan
PE55TWP-220-BS	220/230V, 50/60 Hz, Single Tool
PE55TWP-4-220-BS	220/230V, 50/60 Hz, 4 Tool

Contact factory for CE pump options

LEGACY SERIES ELECTRIC HYDRAULIC PUMP

X1E1-PT
700 bar/10,000 psi



700 BAR (10,000 PSI) CLASSIC SERIES ELECTRIC HYDRAULIC PUMP

The original electric pump! Features a simplified electrical control box and a proven, reliable design. Typically sold to customers that already have a fleet of similar pumps.

Quality means Lower Life-Cycle Costs:

- Over 100,000 cycles
- Continuous duty up to 50°C (122°F) ambient
- Proven design = Proven reliability

Enhanced Usability:

- Power Team, two-speed high performance, PE55 base pump
- Retract side internal relief valve protects tool
- 4-way 2-position solenoid valve standard
- Use with single or double acting tools, not for lifting applications
- Hand remote standard

Designed with Safety in Mind:

- Easily adjusted pressure regulator (relief) valve
- Fixed 103 bar (1,500 psi) pressure retract relief valve

DESIGNED FOR

Electric



Air



Gas



Hand



MAINTENANCE
& REPAIR

ORIGINAL
INSTALL

Split



Tension



Torque



Max
Flow



Specifications and Dimensional Data

Size (L x W x H): 35 cm x 33 cm x 46 cm
13.9" x 13.1" x 18.1"

Weight: 35.3 kg (78 lb) [without oil]

Maximum Oil Capacity: (vented reservoir)
6.8 L (1.8 Gallons) [to fill line]
5.3 L (1.4 Gallons) [usable]

Operating Environment: -25°C to +50°C
(-13°F to +122°F)

(When operating near temperature extremes, it is recommended to use hydraulic oils that are rated for those temperatures. Refer to service manuals and cooling options)

Sound Level: 87-92 dBA (max)

Pressure: 0 - 700 bar (0 - 10,000 psi)

Typical Flow: 11.5 L/min - 0.9 L/min
(704 in³/min - 55 in³/min)

Power: 1-1/8 hp Universal Motor
110/115V - 50/60 Hz (25 amps)
220/230V - 50/60 Hz (13 amps)

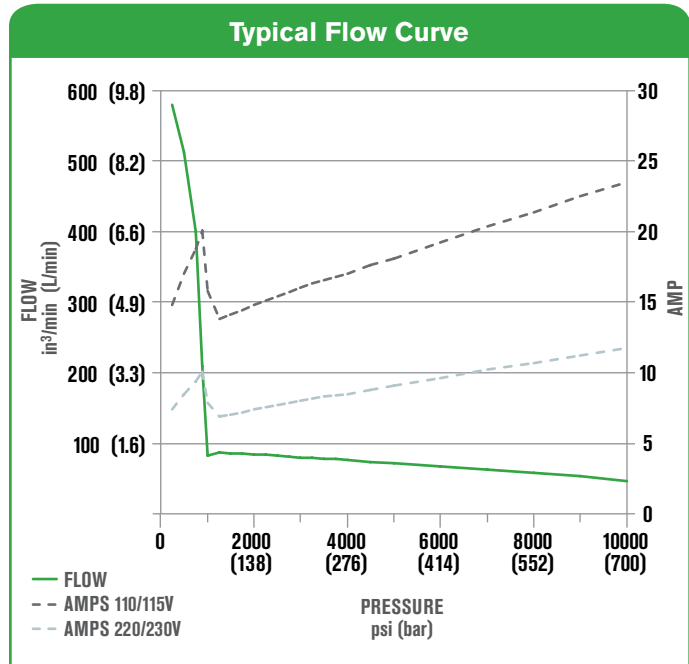

Order No.	Oil Delivery per min.	Oil Reservoir L gal	Usable Oil L in ³	Overall Width cm in	Overall Length cm in	Overall Height cm in	Pump Weight w/Oil kg lb
X1E1-PT	0.9 L @ 700 bar	9.5	5.3	35	33	46	41
	55 in ³ @ 10,000 psi	2.5	324	13.9	13.1	18.1	90

Electrical Data

	Electric Motor	Electrical Control
X1E1-PT	1-1/8 hp, 12000 rpm 110/115V, 50/60 Hz, 25 amps	Remote control with 6 meter (20-foot) cord

Ordering Information

Order No.	Description
X1E1-PT	110/115V, 50/60 Hz, Single Tool
X1E2-PT	220/230V, 50/60 Hz, Single Tool

CLASSIC SERIES GAS HYDRAULIC PUMP

PG120TWP
700 bar/10,000 psi

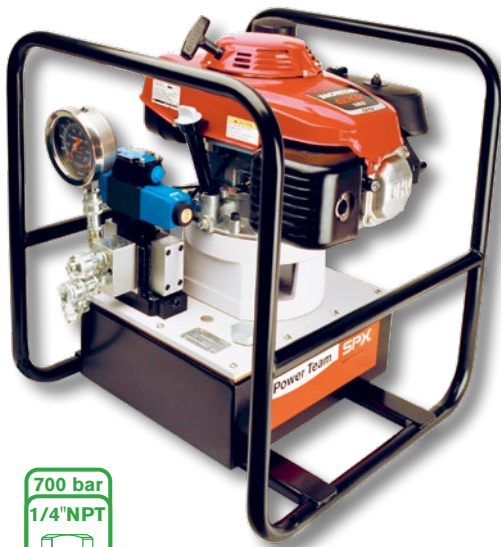

700 BAR (10,000 PSI) CLASSIC SERIES GAS HYDRAULIC PUMP

Gasoline powered pump for use in remote locations where electricity or compressed air are not readily available.

Operates on a powerful 5.5 hp Honda OHV-type engine.

Quality means Lower Life-Cycle Costs:

- High quality, reliable gasoline engine
- Continuous duty
- Proven design = proven reliability

Enhanced Usability:

- Air cooled 4-stroke engine
- Uses standard unleaded gasoline
- Large capacity, multi-chamber exhaust system to reduce noise

Designed with Safety in Mind:

- Fixed 48 bar (700 psi) Unload Valve
- Frame allows for easy two man carry

DESIGNED FOR

Electric



Air



Gas



Hand



MAINTENANCE
& REPAIR

ORIGINAL
INSTALL

Split



Tension



Torque



Max
Flow



Specifications and Dimensional Data

Size (L x W x H): 54 cm x 50 cm x 59 cm
21.25" x 19.75" x 23"

Weight: 55 kg (121 lb) [without oil]

Maximum Oil Capacity: (vented reservoir)
10.2 L (2.7 Gallons) [to fill line]
9.4 L (2.5 Gallons) [usable]

Operating Environment: -25°C to +50°C
(-13°F to +122°F)

(When operating near temperature extremes, it is recommended to use hydraulic oils that are rated for those temperatures. Refer to service manuals and cooling options)

Sound Level: 85-92 dBA (max)

Pressure: 0 - 700 bar (0 - 10,000 psi)

Typical Flow: 7.87 L/min - 2.13 L/min
(480 in³/min - 130 in³/min)

Power: 5.5 hp Honda OHV-Type Gasoline Engine, 3600 rpm

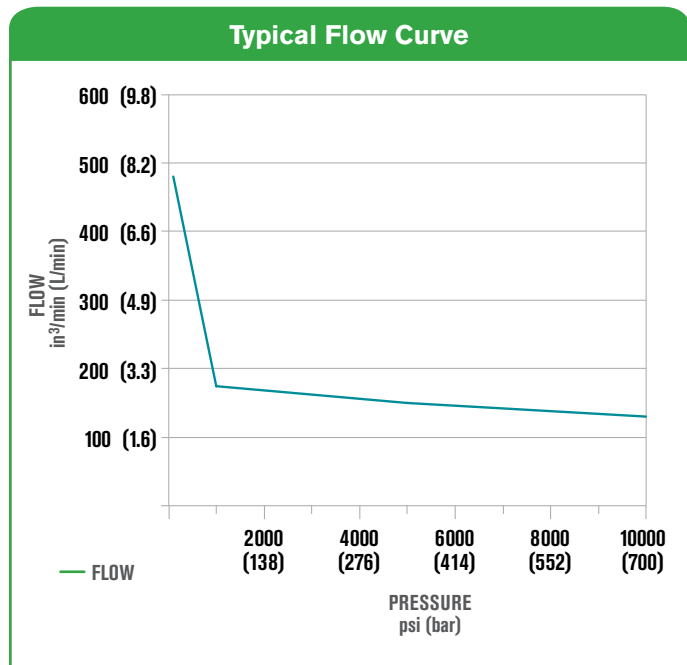

Order No.	Oil Delivery	Oil Reservoir	Usable Oil	Overall Width	Overall Length	Overall Height	Pump Weight w/Oil
	per min.	L gal	L in ³	cm in	cm in	cm in	kg lb
PG120TWP	7.87 L/min @ 7 bar 2.13 L/min @ 700 bar	11.4	9.4	50	54	59	57.2
	480 in ³ @ 100 psi 130 in ³ @ 10,000 psi	3	572	19.75	21.25	23	126

Ordering Information

Order No.	Description
PG120TWP	Gasoline Pump, Single Tool

CLASSIC SERIES AIR HYDRAULIC PUMP

RWP55-BS
700 bar/10,000 psi



700 BAR (10,000 PSI) CLASSIC SERIES AIR HYDRAULIC PUMP

The RWP55-BS has been the market leading pump for over 30 years & is therefore tried & tested. A simple, light-weight design with a recent upgrade that has created a cost-effective workhorse.

Quality means Lower Life-Cycle Costs:

- Over 100,000 cycles
- Continuous duty up to 50°C (122°F) ambient
- Proven design = Proven reliability

Enhanced Usability:

- Powerful 3 hp motor starts under load
- Retract side internal relief valve protects tool
- Use with single or double acting tools. Not for lifting applications
- 4" calibration capable gauge

Designed with Safety in Mind:

- Easily adjusted pressure regulator (relief) valve
- Has a retract port pressure selector 103 or 700 bar (1,500 or 10,000 psi)

DESIGNED FOR

Electric



Air



Gas



Hand



MAINTENANCE & REPAIR

ORIGINAL INSTALL

Split



Tension



Torque



Max Flow



Specifications and Dimensional Data

Size (L x W x H): 42 cm x 24 cm x 50 cm
16.6" x 9.5" x 19.8"

Weight: 38 kg (84 lb) [without oil]

Maximum Oil Capacity: (vented reservoir)
6.8 L (1.8 Gallons) [to fill line]
5.3 L (1.4 Gallons) [usable]

Operating Environment: -25°C to +50°C
(-13°F to +122°F)

(When operating near temperature extremes, it is recommended to use hydraulic oils that are rated for those temperatures. Refer to service manuals and cooling options)

Sound Level: 85-92 dBA (max)

Pressure: 0 - 700 bar (0 - 10,000 psi)

Typical Flow: 7.6 L/min - 0.9 L/min
(465 in³/min - 55 in³/min)

Air: 1.4 m³/min @ 5.5 bar (50 cfm @ 80 psi)
1.65 m³/min @ 6.2 bar (58 cfm @ 90 psi)
1.89 m³/min @ 6.9 bar (67 cfm @ 100 psi)

* Values shown are with filter/regulator/lubricator.
Values will increase without filter/regulator/
lubricator.

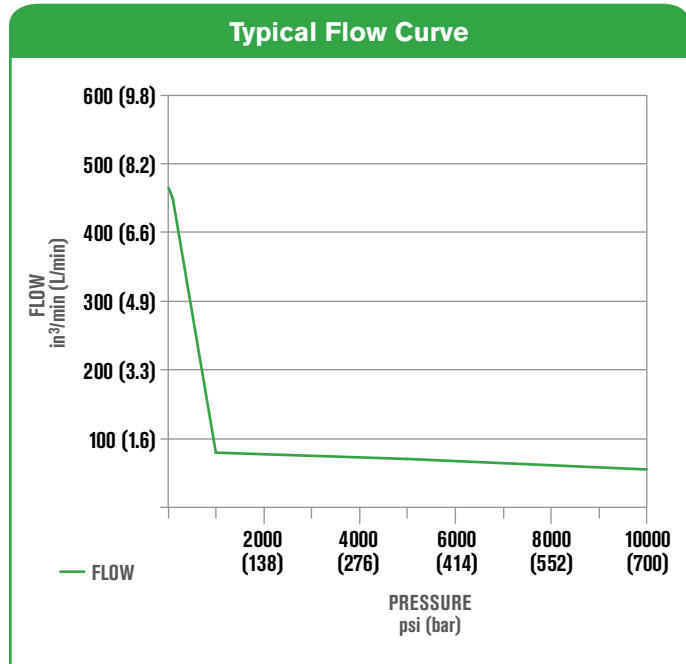

Order No.	Oil Delivery per min	Oil Reservoir L (gal)	Usable Oil L (in ³)	Overall Width mm (in)	Overall Length mm (in)	Overall Height mm (in)	Pump Weight w/Oil kg (lb)
RWP55-BS	7.6 L @ 7 bar 0.9 L @ 700 bar	9.5 (2.5)	5.3 (324)	420 (16.55)	241 (9.5)	503.7 (19.83)	44 (98)
	465 in ³ @ 100 psi 55 in ³ @ 10,000 psi						
RWP55-4-BS (4-tool manifold)	7.6 L @ 7 bar 0.9 L @ 700 bar	9.5 (2.5)	5.3 (324)	420 (16.55)	241 (9.5)	503.7 (19.83)	44 (98)
	465 in ³ @ 100 psi 55 in ³ @ 10,000 psi						

Motor Data

	Air Motor	Air Control
RWP55-BS	1.4 m ³ /min @ 5.5 bar 3 hp, 50 cfm @ 80 psi	Pneumatic remote control with 6 meter (25-foot) cord

Ordering Information

Order No.	Description
RWP55-BS	Air Pump, Single tool
RWP55-BS-R	Air Pump, Single tool, with roll cage
RWP55-4-BS	Air Pump, 4 tool
RWP55-4-BS-R	Air Pump, 4 tool, with roll cage

LEGACY SERIES AIR HYDRAULIC PUMP

X1A1-PT
700 bar/10,000 psi

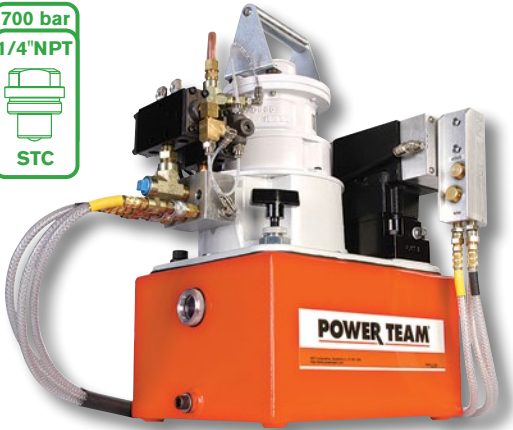

700 BAR (10,000 PSI) CLASSIC SERIES AIR HYDRAULIC PUMP

The original air pump! Features a proven, reliable design. Typically sold to customers that already have a fleet of similar pumps.

Quality means Lower Life-Cycle Costs:

- Over 100,000 cycles
- Continuous duty up to 50°C (122°F) ambient
- Proven design = Proven reliability

Enhanced Usability:

- Power Team, two-speed high performance, PA55 base pump
- Retract side internal relief valve protects tool
- 4-way 2-position air pilot valve standard
- Use with single or double acting tools. Not for lifting applications.
- Hand remote standard

Designed with Safety in Mind:

- Easily adjusted pressure regulator (relief) valve
- Fixed 103 bar (1,500 psi) pressure retract relief valve

DESIGNED FOR

Electric



Air



Gas



Hand



MAINTENANCE
& REPAIR

ORIGINAL
INSTALL

Split



Tension



Torque



Max
Flow



Specifications and Dimensional Data

Size (L x W x H): 27 cm x 46 cm x 48 cm
10.8" x 18" x 18.8"

Weight: 34 kg (75 lb) [without oil]

Maximum Oil Capacity: (vented reservoir)
6.8 L (1.8 Gallons) [to fill line]
5.3 L (1.4 Gallons) [usable]

Operating Environment: -25°C to +50°C
(-13°F to +122°F)

(When operating near temperature extremes, it is recommended to use hydraulic oils that are rated for those temperatures. Refer to service manuals and cooling options)

Sound Level: 85-92 dBA (max)

Pressure: 0 - 700 bar (0 - 10,000 psi)

Typical Flow: 7.6 L/min - 0.9 L/min
(465 in³/min - 55 in³/min)

Air: 1.4 m³/min @ 5.5 bar (50 cfm @ 80 psi)
1.65 m³/min @ 6.2 bar (58 cfm @ 90 psi)
1.89 m³/min @ 6.9 bar (67 cfm @ 100 psi)

* Values shown are with filter/regulator/lubricator.
Values will increase without filter/regulator/
lubricator.

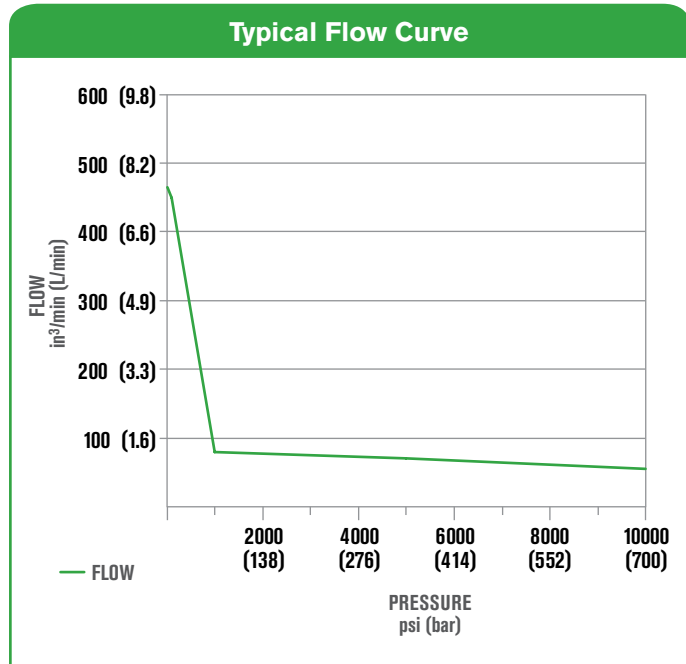

Order No.	Oil Delivery per min	Oil Reservoir L (gal)	Usable Oil L (in ³)	Overall Width mm (in)	Overall Length mm (in)	Overall Height mm (in)	Pump Weight w/Oil kg (lb)
X1A1-PT	7.6 L @ 7 bar 0.9 L @ 700 bar	9.5 (2.5)	5.3 (324)	273 (10.75)	457 (18)	476 (18.75)	40 (89)
	465 in ³ @ 100 psi 55 in ³ @ 10,000 psi						

Ordering Information

Order No.	Description
X1A1-PT	Air Pump, Single tool

HAND PUMPS

HYDRAULIC P SERIES

700 bar/10,000 psi

PUMP AUTOMATICALLY SHIFTS INTO THE HIGH PRESSURE STAGE UPON CONTACT WITH THE LOAD.

- All metal construction won't burn through in welding environments.
- Two-speed reduces handle strokes so you work faster and easier.
- Convenient fill port allows pumps to be filled in a horizontal or vertical position.
- Relief valve inboard of check valve prevents loads from drifting down.
- Large valve knob gives added control for slowly metering loads down.

P19L/P59L

- More usable oil volume — use with larger or longer stroke cylinders.
- True unloading valve set for 59 bar (850 psi) provides more efficiency and lower handle force.
- Link design reduces handle effort by 40%.
- Durable aluminum reservoir, manifold, and end cap.
- Ergonomic non-slip handle grip provides more comfort.
- Spring loaded handle lock incorporated into handle.

P19/P59/P59F

- Steel reservoir
- Strong lever
- Lower handle effort (measured)
- Higher unloading pressure 22 bar (325 psi)
- Pump is serviceable (all components available)
- Durable aluminum pump head
- No breather opening needed (so no leakage)
- True unloading (more flow/ lower effort)
- Pump mounting holes on front and back
- Solid accurate repeatable Integrated lifting system
- Can be used in welding environment (no plastic)



DESIGNED FOR

Electric



Air



Gas



Hand



MAINTENANCE & REPAIR

ORIGINAL INSTALL

Split



Tension



Torque



Max Flow



No coupler included with these pumps.

Specifications and Dimensional Data

Operating Environment: -25°C to +50°C
(-13°F to +122°F)

(When operating near temperature extremes, it is recommended to use hydraulic oils that are rated for those temperatures. Refer to service manuals and cooling options)

Pressure: 0 - 700 bar (0 - 10,000 psi)

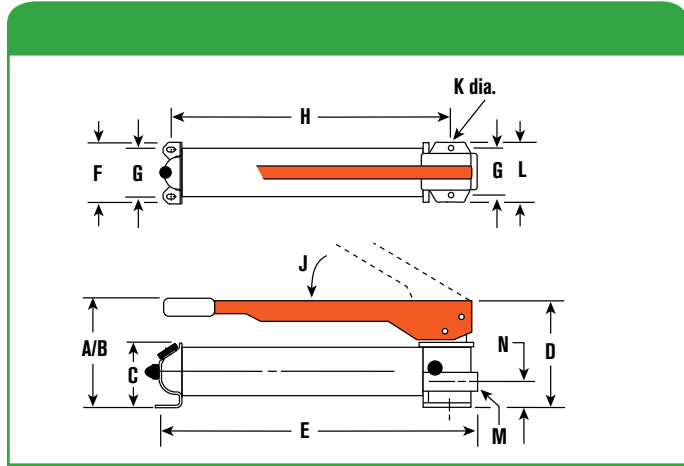

Order No.	A mm in	B mm in	C mm in	D mm in	E mm in	F mm in	G mm in	H mm in	J deg	K mm in	L mm in	M in	N mm in
P19	476	371	73	116	348	102	83	281	53°	8	102	3/8 NPTF	36
	5-1/2	14-5/8	2-7/8	4-9/16	13-11/16	4	3-1/4	11-1/16	53°	5/16	4	3/8 NPTF	1-13/32
P19L	476	-	-	-	348	105	83	279	40°	8	-	3/8 NPTF	-
	5-1/2	-	-	-	13-11/16	4-1/8	3-1/4	11	40°	5/16	-	3/8 NPTF	-
P59	178	533	89	127	584	114	89	502	38°	8	121	3/8 NPTF	41
	7	21	3-1/2	5	23	4-1/4	3-1/4	19-3/4	38°	5/16	4-3/4	3/8 NPTF	1-5/8
P59L	178	-	-	-	533	127	83	502	50°	8	-	3/8 NPTF	-
	7	-	-	-	21	5	3-1/4	19-3/4	50°	5/16	-	3/8 NPTF	-
P59F	89	425	89	152	591	114	83	514	-	8	114	3/8 NPTF	-
	3-1/2	16-3/4	3-1/2	6	23-1/4	4-1/4	3-1/4	20-1/4	-	5/16	4-1/2	3/8 NPTF	-

Ordering Information

For Use With	Order No.	Speed	Volume & Pressure								Reservoir Handle Effort		Oil Capacity		Usable Oil Capacity		Oil Port	Product Weight	
			Volume per Stroke				Maximum Pressure				(kg)	(lb)	(cm³)	(in³)	(cm³)	(in³)	(in)	(kg)	(lb)
			LP	HP	LP	HP	LP	HP	LP	HP									
Single Acting	P19	2	5.0	0.305	1.2	0.076	22	325	700	10,000	45	99	400	24.4	328	20	3/8 NPTF	3.0	6.6
	P19L	2	4.1	0.250	0.8	0.050	59	850	700	10,000	35	78	475	29	443	27	3/8 NPTF	2.3	5.1
	P59	2	10.8	0.662	2.6	0.160	22	325	700	10,000	66	145	901	55	737	45	3/8 NPTF	7.8	17.2
Tools & Cylinders*	P59L	2	12.0	0.720	2.5	0.150	59	850	700	10,000	47	104	1131	69	1082	66	3/8 NPTF	4.0	8.9
	P59F	2	9.0	0.550	2.1	0.130	22	325	700	10,000	54	120	901	55	737	45	3/8 NPTF	6.4	14

LP = Low Pressure
HP = High Pressure
*Pump includes 2-Way Valve



Foot Pump Conversion Kit

No. FK59 - Foot pump conversion kit for use on P55/P59 pumps. Wt., 2.7 kg (6 lb)

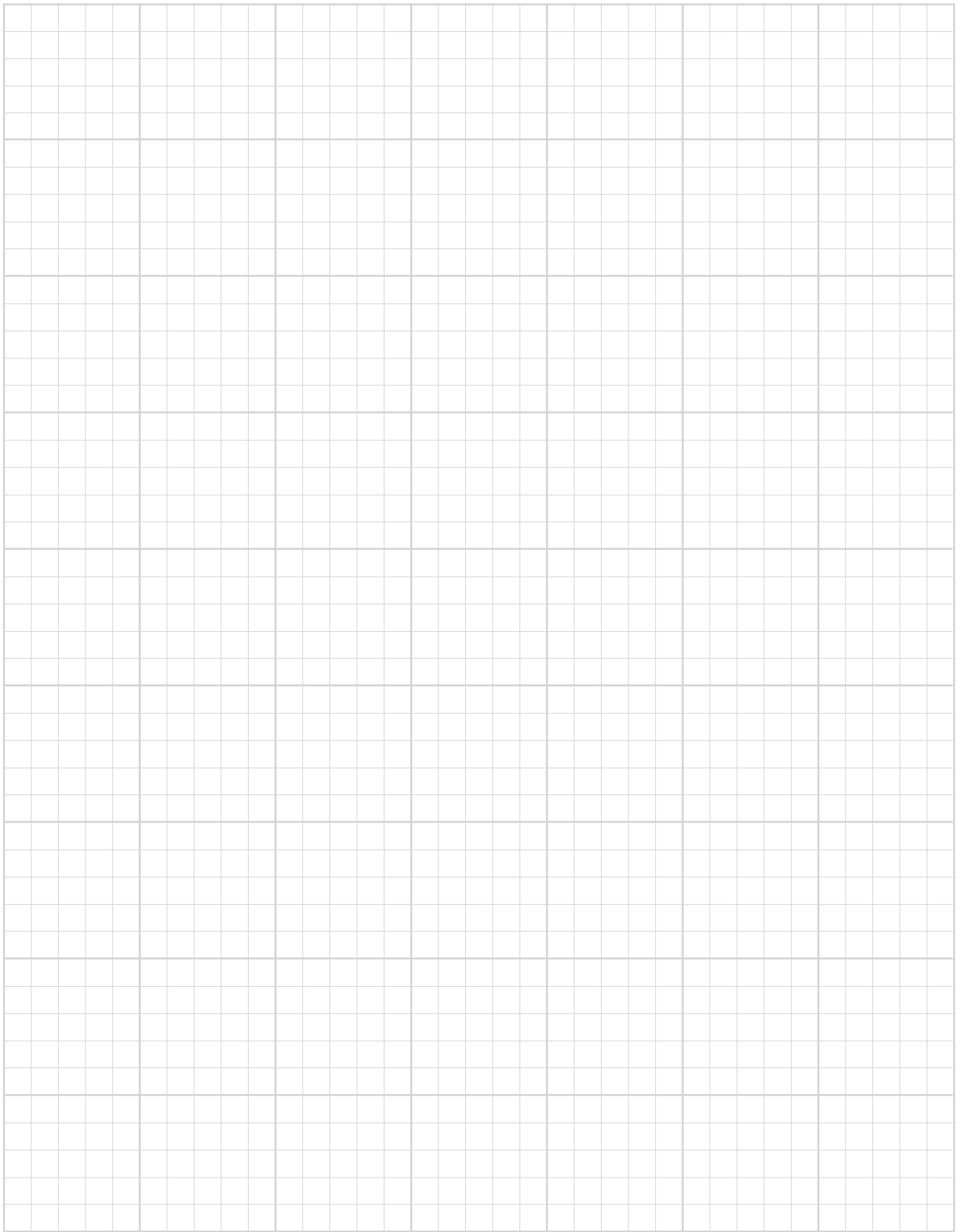

PUMPS

FOR TENSIONERS

1,500 BAR (21,750 PSI) - HIGH PERFORMANCE HYDRAULIC PUMPS

Page
PE8...92-93
High Pressure Electric Pump



Page
HPUTP-2...96-97
High Flow & Subsea Tensioner
Power Pack



Page
HPUTP-1...94-95
Standard Flow Tensioner
Power Pack



Page
**HIGH PRESSURE
HAND PUMPS...98-99**
1,500 bar (21,750 psi)



SIDE BY SIDE COMPARISON OF HPUTP-1 AND HPUTP-2 PUMPS

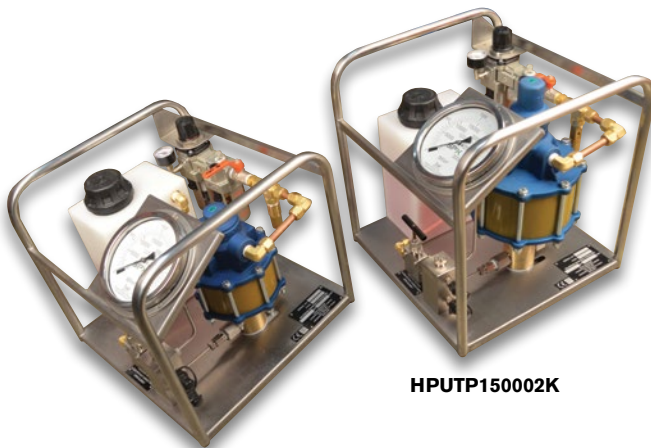

HPUTP150001K

HPUTP150002K

The HPUTP-2 produces more flow, has a larger motor and frame and weighs approximately 4 kg (9 lb) more.



CAUTION! These pumps can produce pressure in excess of 700 bar (10,000 psi). Check all components that are used with these pumps and never exceed the rated pressure of any component.

HIGH PRESSURE ELECTRIC PUMP

PE8
1,500 bar/21,750 psi



1,500 BAR (21,750 PSI) HIGH PRESSURE ELECTRIC PUMP

The PE8 is a very high pressure pump that incorporates proven design for reliable operation. It is based on proven pump design for reliability in rugged bolt tensioning applications.

Quality means Lower Life-Cycle Costs:

- Over 100,000 cycles
- Continuous duty up to 50°C (122°F) ambient
- Proven design = Proven reliability

Enhanced Usability:

- Light Weight and portable: 20.6 kg (45.5 lb) [without oil]
- Quick Release, removable control pendant (5 m/15 ft)
- Removable 100 mm (4"), calibration-capable, gauge
- Universal Motor for reduced voltage applications (up to -20% nominal voltage)
- SPX FLOW Tensioners are designed to daisy-chain together so multiple tools can run off one pump
- Compact design fits into tight spaces

Designed with Safety in Mind:

- Easily adjusted pressure regulator (relief) valve

DESIGNED FOR

Electric



Air



Gas



Hand



MAINTENANCE & REPAIR

ORIGINAL INSTALL

Split



Tension



Torque



Max Flow



Specifications and Dimensional Data

Size (L x W x H): 35.8 cm x 19.8 cm x 41.4 cm
14.1" x 7.8" x 16.3"

Weight: 20.6 kg (45.5 lb) [without oil]

Maximum Oil Capacity: (vented reservoir)
3.8 L (1.0 Gallons) [to fill line]
3.4 L (0.9 Gallons) [usable]

Operating Environment: -25°C to +50°C
(-13°F to +122°F)

(When operating near temperature extremes, it is recommended to use hydraulic oils that are rated for those temperatures. Refer to service manuals and cooling options)

Sound Level: 87-92 dBA (max)

Pressure: 0 - 1,500 bar (0 - 21,750 psi)

Typical Flow: 2.7 L/min - 0.13 L/min
(168 in³/min - 8 in³/min)

Power: 0.5 hp Universal Motor
110/115V - 50/60 Hz (11 amps)
220/230V - 50/60 Hz (5.5 amps)

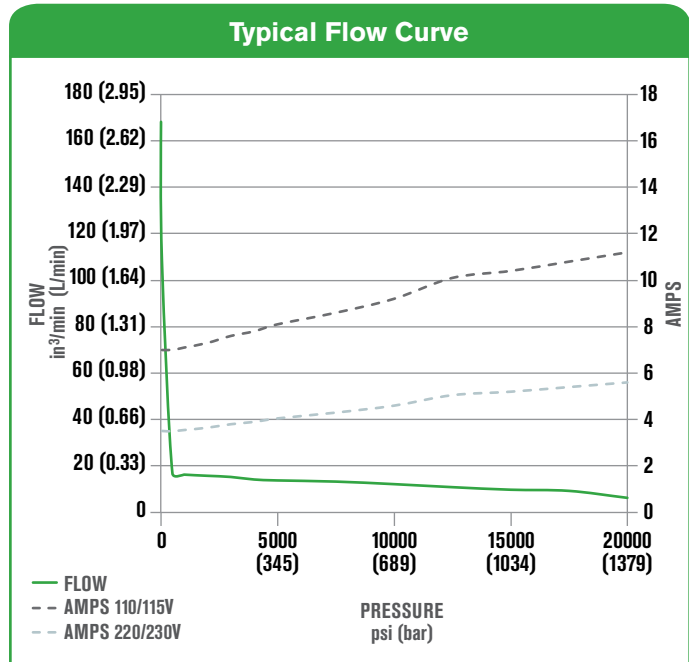

Ordering Information

Order No.	Description
PE8LXX3L	110/115VAC 50/60Hz Motor
PE8PXX3L	220/230VAC 50/60Hz Motor

STANDARD FLOW TENSIONER PUMP

HPUTP-1

1,500 bar/21,750 psi



HPUTP150001K



1,500 BAR (21,750 PSI) TOPSIDE BOLT TENSIONER & HYDRAULIC NUT PUMP

Standard flow tension pump. Corrosion resistant frame works well for applications near salt water. Standard flow ideal for land based (topside) tension applications where the required power source is compressed air.

Quality means Lower Life-Cycle Costs:

- Over 100,000 cycles
- Continuous duty up to 50°C (122°F) ambient
- Proven design = Proven reliability

Enhanced Usability:

- Calibrated 150 mm (6") Pressure Gauge
- Dual oil outlets with quick-connect, no spill couplings
- Pneumatic Filter/Regulator/Lubricator included
- Stainless Steel carrying frame

Designed with Safety in Mind:

- Easily adjusted pressure regulator valve
- Air pressure safety relief valve

DESIGNED FOR

Electric



Air



Gas



Hand



MAINTENANCE
& REPAIR

ORIGINAL
INSTALL

Split



Tension



Torque



Max
Flow



Specifications and Dimensional Data

Size (L x W x H): 42 cm x 42 cm x 39 cm
16.5" x 16.5" x 15.5"

Weight: 21 kg (46 lb) [without oil]

Maximum Oil Capacity: (vented reservoir)
9.5 L (2.5 Gallons) [to fill line]
9.4 L (2.5 Gallons) [usable]

Operating Environment: -25°C to +50°C
(-13°F to +122°F)

(When operating near temperature extremes, it is recommended to use hydraulic oils that are rated for those temperatures. Refer to service manuals and cooling options)

Sound Level: 85 dBA (max)

Pressure: 0 - 1,500 bar (0 - 21,750 psi)

Typical Flow: 0.72 L/min - 0.28 L/min
(44 in³/min - 17 in³/min)

Air: 0.68 m³/min @ 5.5 bar (24 cfm @ 80 psi)
0.74 m³/min @ 6.2 bar (26 cfm @ 90 psi)
0.80 m³/min @ 6.9 bar (28 cfm @ 100 psi)

* Values shown are with filter/regulator/lubricator.
Values will increase without filter/regulator/
lubricator.



Typical Flow Curve

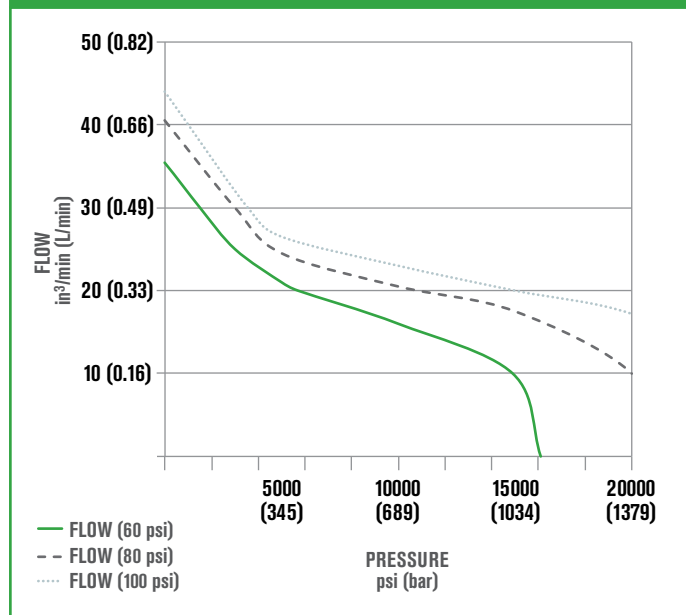

Hydraulic Oil Delivery

	@ 6.9 bar @ 100 psi	@ 5.5 bar @ 80 psi	@ 4.1 bar @ 60 psi
51 bar (750 psi)	0.67 L/min (41 in ³ /min)	0.62 L/min (38 in ³ /min)	0.54 L/min (33 in ³ /min)
175 bar (2,500 psi)	0.57 L/min (35 in ³ /min)	0.54 L/min (33 in ³ /min)	0.44 L/min (27 in ³ /min)
350 bar (5,000 psi)	0.44 L/min (27 in ³ /min)	0.40 L/min (25 in ³ /min)	0.34 L/min (21 in ³ /min)
689 bar (10,000 psi)	0.38 L/min (23 in ³ /min)	0.34 L/min (21 in ³ /min)	0.26 L/min (16 in ³ /min)
1,000 bar (15,000 psi)	0.33 L/min (20 in ³ /min)	0.29 L/min (18 in ³ /min)	0.15 L/min (9 in ³ /min)
1,500 bar (21,750 psi)	0.24 L/min (15 in ³ /min)	-	-

Ordering Information

Order No.	Description
HPUTP150001K	1,500 Bar (21,750 psi) Standard Flow Tensioner Pump

HIGH FLOW & SUBSEA TENSIONER PUMP

HPUTP-2
1,500 bar/21,750 psi

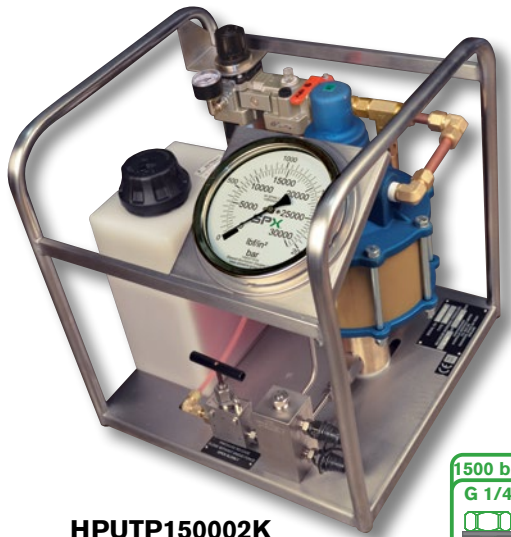

HPUTP150002K

1,500 BAR (21,750 PSI) SUBSEA & LARGE TENSIONER APPLICATIONS

High flow tension pump. Corrosion resistant frame works well for applications near salt water. High flow ideal for subsea applications where compressed air is the required power source.

Quality means Lower Life-Cycle Costs:

- Over 100,000 cycles
- Continuous duty up to 50°C (122°F) ambient
- Proven design = Proven reliability

Enhanced Usability:

- Calibrated 150 mm (6") Pressure Gauge
- Dual oil outlets with quick-connect, no spill couplings
- Pneumatic Filter/Regulator/Lubricator included
- Stainless Steel carrying frame

Designed with Safety in Mind:

- Easily adjusted pressure regulator valve
- Air pressure safety relief valve

DESIGNED FOR

Electric



Air



Gas



Hand



MAINTENANCE & REPAIR

ORIGINAL INSTALL

Split



Tension



Torque



Max Flow



Specifications and Dimensional Data

Size (L x W x H): 46 cm x 53 cm x 52 cm
17.9" x 20.8" x 15.3"

Weight: 23 kg (51 lb) [without oil]

Maximum Oil Capacity: (vented reservoir)
9.5 L (2.5 Gallons) [to fill line]
9.4 L (x2.5 Gallons) [usable]

Operating Environment: -25°C to +50°C
(-13°F to +122°F)

(When operating near temperature extremes, it is recommended to use hydraulic oils that are rated for those temperatures. Refer to service manuals and cooling options)

Sound Level: 85 dBA (max)

Pressure: 0 - 1,500 bar (0 - 21,750 psi)

Typical Flow: 1.15 L/min - 0.50 L/min
(70 in³/min - 31 in³/min)

Air: 1.42 m³/min @ 5.5 bar (52 cfm @ 80 psi)
1.53 m³/min @ 6.2 bar (54 cfm @ 90 psi)
1.60 m³/min @ 6.9 bar (56 cfm @ 100 psi)

* Values shown are with filter/regulator/lubricator.
Values will increase without filter/regulator/
lubricator.



Typical Flow Curve

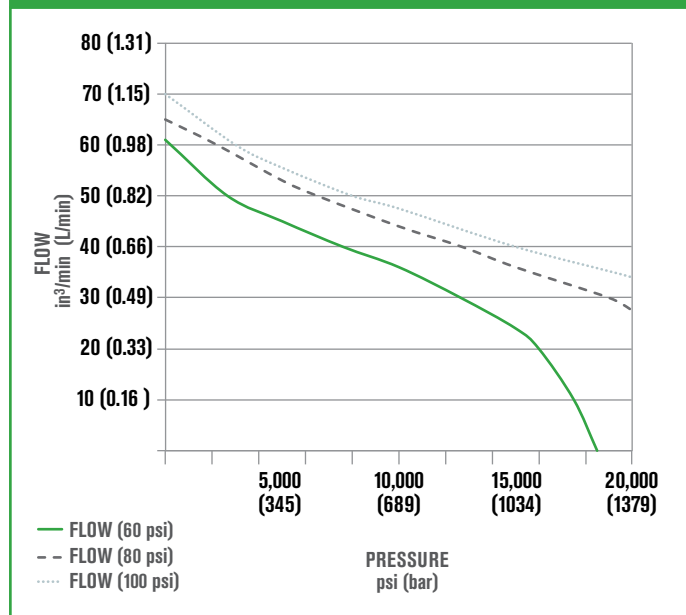

Hydraulic Oil Delivery

	@ 6.9 bar @ 100 psi	@ 5.5 bar @ 80 psi	@ 4.1 bar @ 60 psi
51 bar (750 psi)	1.11 L/min (68 in ³ /min)	1.04 L/min (63 in ³ /min)	0.97 L/min (59 in ³ /min)
175 bar (2,500 psi)	1.03 L/min (63 in ³ /min)	0.97 L/min (59 in ³ /min)	0.87 L/min (53 in ³ /min)
350 bar (5,000 psi)	0.91 L/min (56 in ³ /min)	0.87 L/min (53 in ³ /min)	0.74 L/min (45 in ³ /min)
689 bar (10,000 psi)	0.78 L/min (48 in ³ /min)	0.72 L/min (44 in ³ /min)	0.59 L/min (36 in ³ /min)
1,000 bar (15,000 psi)	0.66 L/min (40 in ³ /min)	0.59 L/min (36 in ³ /min)	0.39 L/min (24 in ³ /min)
1,500 bar (21,750 psi)	0.51 L/min (31 in ³ /min)	-	-

Ordering Information

Order No.	Description
HPUTP150002K	1,500 Bar High Flow Tensioner Pump

HIGH PRESSURE HAND PUMP

1,500 bar/21,750 psi



P59L-1500



P59L-1500G

TWO STAGE, HIGH PRESSURE HAND PUMP

- Pressure Range - 0 to 1500 bar (0 to 21,750 psi)
- Two-speed design reduces handle effort by 40%
- Fiberglass handle provides rigidity, and reduces operator fatigue with grip.
- Convenient fill port enables pumps to be filled in a horizontal or vertical position.
- Fill cap seal acts as safety valve preventing over-pressurizing of reservoir.
- Large valve knob gives added control for slowly metering loads down.
- P59L-1500G model comes with a skid plate for stabilization and a digital pressure gauge.
- Extremely lightweight, easy to transport with the aluminum body design.

DESIGNED FOR

Electric



Air



Gas



Hand



MAINTENANCE
& REPAIR

ORIGINAL
INSTALL

Split



Tension



Torque



Max
Flow



Specifications and Dimensional Data

Size: (L x W x H): 56 cm x 14 cm x 18 cm
21.94" x 5.47" x 7.17"

Weight: 4.7 kg (10.4 lb) [with oil]

Maximum Oil Capacity: (vented reservoir)
1.1 L (0.29 Gallons) [to fill line]
0.7 L (0.18 Gallons) [usable]

Operating Environment: -25°C to +50°C
(-13°F to +122°F)

(When operating near temperature extremes, it is recommended to use hydraulic oils that are rated for those temperatures. Refer to service manuals and cooling options)

Pressure: 0 - 1,500 bar (0 - 21,750 psi)

Typical Flow: 11 cm³ stroke - 0.8 cm³ stroke
(0.68 in³/stroke - 0.05 in³/stroke)

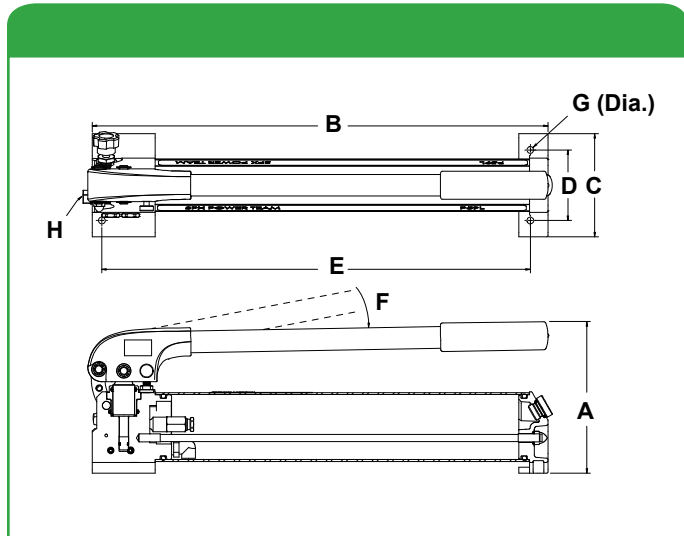

Order No.	A mm in	B mm in	C mm in	D mm in	E mm in	F deg	G in	H in
P59L-1500	182	556	139	83	502	7	5/16	9/16-18 UNF-2B **
	7.17	21.91	5.47	3.25	19.75	47	5/16	9/16-18 UNF-2B **
P59L-1500G*	182	556	139	83	502	7	5/16	9/16-18 UNF-2B **
	7.17	21.91	5.47	3.25	19.75	47	5/16	9/16-18 UNF-2B **

* Overall length, with the skid plate, is 718.8 mm (28.30 in.).



** High pressure 60° cone port.

Ordering Information

For use with	Order No	Speed	Volume per Stroke		Maximum Pressure		Handle Effort	Oil Capacity	Usable Oil Capacity	Oil Port	Product Weight
			LP cm ³ in ³	HP cm ³ in ³	LP bar psi	HP bar psi					
Tensioners	P59L-1500	2	11	0.8	20.7	1,500	320	1	1		4.7
			0.68	0.05	300	21,750	72	67.1	44.5	3/4 - 16 UNF	10.4
Tensioners	P59L-1500G*	2	11	0.8	20.7	1,500	320	1	1		6.5
			0.68	0.05	300	21,750	72	67.1	44.5	3/4 - 16 UNF	14.4

* Equipped with a skid plate and a digital gauge.

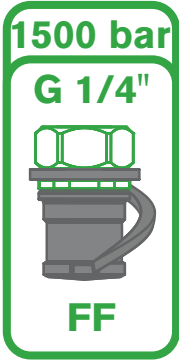
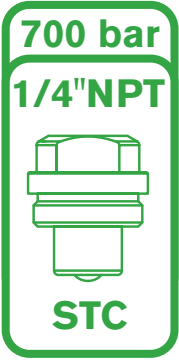
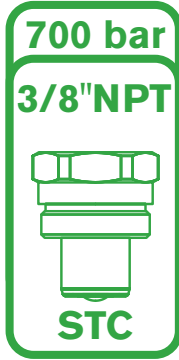
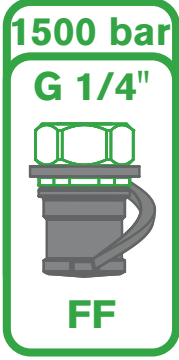
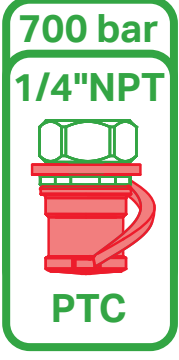
Coupler Explanation

	1,500 BAR (21,750 PSI)	700 BAR (10,000 PSI)	
	TENSIONERS	TORQUE WRENCHES ENS SPLITTER	OTHER TOOLS
TOPSIDE	 <p>1500 bar G 1/4" FF</p>	 <p>700 bar 1/4" NPT STC</p>	 <p>700 bar 3/8" NPT STC</p>
SUBSEA	 <p>1500 bar G 1/4" FF</p>	 <p>700 bar 1/4" NPT PTC</p>	

Male FF couplers can connect to recessed style (standard), push to connect (PTC) couplers and Flat Face (optional) couplers. Contact factory for information about Flat Face coupler options.

Coupler Icon Explanation

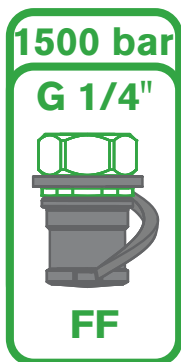

RATED PRESSURE

700 bar (10,000 psi) or 1,500 bar (21,750 psi)

THREAD TYPE

1/4" NPT or 3/8" NPT or G 1/4"

ICON

COUPLER TYPE

STC = Screw to Connect or FF = Flat Face or
PTC = Push to Connect

No Coupler Included

Some products do not include couplers. Couplers need to be ordered separately.



ACCESSORIES

Page
**TOPSIDE TORQUE
WRENCH...102**

Hoses, Couplers, and
Accessories



Page
**HYDRAULIC
FLUIDS...107**

Standard
Flame Out
Biodegradable
Low Temperature



Page
**TENSION
HOSES...103**

Hoses, Couplers, and
Accessories



Page
**FLANGE MANAGEMENT
SYSTEMS...108-109**

Flangepro



Page
**SUBSEA TORQUE
WRENCH...104**

Hoses, Couplers, and
Accessories



Page
**BOLT LOAD
CALCULATOR...110-111**

Advisor



Page
**SUBSEA
TENSION...105**

Hoses, Couplers, and
Accessories



Page
TRAINING...112-113

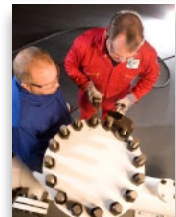

Page
**SPLITTERS &
SPREADERS...106**

Hoses, Couplers, and
Accessories



Page
**RENTAL & SERVICE
CENTERS...114-115**



**TOPSIDE
TORQUE WRENCH**
1/4" COUPLERS
700 bar/10,000 psi







Twin-line Topside Hoses

Standard Twin-line Hoses (4:1 Burst)	
Order No.	DESCRIPTION
TWH15-BS	15 ft twin-line hose
TWH20-BS	20 ft twin-line hose
TWH50-BS	50 ft twin-line hose

Standard CE Twin-line Hoses (4:1 Burst)	
Order No.	DESCRIPTION
TWH3E	3 meter twin-line hose
TWH6E	6 meter twin-line hose
TWH10E	10 meter twin-line hose

Additional lengths (all styles) available upon request.

9072		700 bar, 10,000 psi gauge for torque wrench applications
9042DG		700 bar, 10,000 psi gauge for torque wrench applications. Custom scale enables the following units to be displayed: lb-ft or Nm
252365		Metal Dust Cover for male coupler
252364		Metal Dust Cover for female coupler
(male) 251411		Quick-connect, screw-on male nipple. Used on 700 bar torque wrenches, nutsplitters, hoses, and pumps. 1/4" NPT Female Thread
(female) 251410		Quick-connect, screw-on female coupling. Used on 700 bar torque wrenches, nutsplitters, hoses, and pumps. 1/4" NPT Male Thread

Refer to page 114 for complete calibration services

Tensioner Hoses





Order No.	Topside, with Locking Collar DESCRIPTION
HL1M	1 m Hose, 1,500 bar, CE, with locking collar (only stocked in Europe & Asia)
HL13M	1.3 m Hose, 1,500 bar, CE, with locking collar (Optionally available in the Americas)
HL3M	3 m Hose, 1,500 bar, CE, with locking collar
HL5M	5 m Hose, 1,500 bar, CE, with locking collar
HL8M	8 m Hose, 1,500 bar, CE, with locking collar
HL10M	10 m Hose, 1,500 bar, CE, with locking collar

Additional lengths available upon request.

TENSION HOSES

1,500 bar/21,750 psi



9042D61500		1,500 bar; 21,750 psi digital gauge for P59L-1500 pumps
2002278		2,000 bar; 30,000 psi gauge for PE8 pumps. Typically attached with quick coupler (ordered separately).
HHAMA150001		1,500 Bar Elbow Block: Used to change direction of tensioner hoses if standard orientation is not possible. Hoses can swivel around coupling axis.
HHAMA150003		1,500 Bar Tee Block Assembly: Used to interconnect tensioners with single ports.
HHAMA150004		1,500 Bar Banjo Assembly: Used to allow a hose to connect to a tool at 90 degrees. The nipple can be oriented in any direction around the port axis but must be tightened to create a seal. Does not act as a swivel around port axis.

2001772		Male Coupling: Quick-connect, push-in male nipple. Used on 1,500 bar tensioners and pumps. 6 1/4" Female Thread
2008548		Female Coupling: Quick-connect, push-in female coupling with locking collar. Used on 1,500 bar tensioners hoses. 6 1/4" Female Thread.
STDHC000025		1/4" BSP Plug: Used to plug a port when a banjo assembly or coupling will not be used.

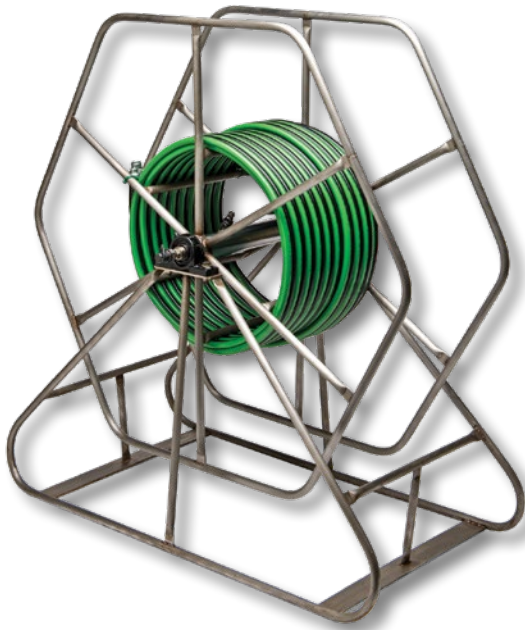

Hoses come standard with recessed female coupler type (2008548). Flat Face couplers available upon request.

**SUBSEA
TORQUE WRENCH
1/4" COUPLERS
700 bar/10,000 psi**



Hose reel stand complete with twin down line for offshore equipment use.

Couplers for hose reel and offshore equipment.

<p>(male) 251411</p>		<p>Quick-connect, screw-on male nipple. Used on 700 bar torque wrenches, nutsplitters, hoses, and pumps. 1/4" NPT Female Thread</p>
<p>(female) 251410</p>		<p>Quick-connect, screw-on female coupling. Used on 700 bar torque wrenches, nutsplitters, hoses, and pumps. 1/4" NPT Male Thread</p>

Remote Diver Control Valve (HCUCV070001) uses 1 each of all four couplings shown on this page.

SUBSEA TWIN-LINE HOSES



SPX FLOW can customize a reel and hose combination for your specific job. Standard reel construction is powder coated carbon steel. Aluminum reels optional. Contact factory for details.

Twin-line Subsea Hoses	
Standard CE Twin-line Subsea Hoses (4:1 Burst)	
Order No.	DESCRIPTION
TWH06E-SS	6 meter (20 ft) twin-line subsea hose, uses red couplers shown below (2008549 & 2008550)
Downline Twin-line Hoses (4:1 Burst)	
Order No.	DESCRIPTION
TWH30E-SS	TWH30E-SS 30 meter (100ft) twin-line, uses screw together couplers (251411 & 251410) configured to be able to join multiple lengths together on Hose reel
TWH100-SS	30 meter (100 ft) twin-line subsea hose, uses stainless steel couplers

Additional lengths (all styles) available upon request.

9072		700 bar, 10,000 psi gauge for torque wrench applications
9042DG		700 bar, 10,000 psi gauge for torque wrench applications. Custom scale enables the following units to be displayed: lb-ft or Nm

Couplers for Diver Control Valve and select subsea tools.

(male) 2008549		Quick-connect, push-in male nipple. Used on Subsea 700 bar torque wrenches, nutsplitters, flange pullers, hoses, and pumps. 1/4" NPT Female Thread
(female) 2008550		Quick-connect, push-in female coupling with locking collar. Used on 700 bar torque wrenches, nutsplitters, flange pullers, hoses, and pumps. 1/4" NPT Female Thread

SUBSEA TENSION HOSES

SPX FLOW can customize a reel and hose combination for your specific job. Standard reel construction is powder coated carbon steel. Stainless hose reels optional. Contact factory for details.

Downline hoses usually supplied in 30 m lengths, male/female quick connect couplings so they can be linked together to make up the desired length of hose.

Maximum hose length capacity 500 m

Subsea Tensioner Hoses	
Order No.	Subsea, without Locking Collar DESCRIPTION
HL1M	1 m Hose, 1,500 bar, CE, with locking collar (only stocked in Europe & Asia)
HL13M	1.3 m Hose, 1,500 bar, CE, with locking collar (Optionally available in the Americas)
HL3M	3 m Hose, 1,500 bar, CE, with locking collar
HL5M	5 m Hose, 1,500 bar, CE, with locking collar
HL8M	8 m Hose, 1,500 bar, CE, with locking collar
HL10M	10 m Hose, 1,500 bar, CE, with locking collar
Order No.	Subsea down-line hose DESCRIPTION
HL30M-DL	30 m Hose, 1500 bar, CE, with locking collar, 1 x male + 1 x female coupler with locking collar. Used to link hoses together between hose reel and subsea work site.

Additional lengths available upon request.

9042D61500		1,500 bar; 21,750 psi digital gauge for P59L-1500 pumps
HPSTP150004		2,000 bar; 30,000 psi analog gauge for P59L-1500 pumps
HHAMA15002		1,500 Bar 3-Port Manifold Assembly: Used in Subsea hose arrangement to split single downline into two hoses which connect to the first two tensioners in the circuit. Can also be used to split a single feed hose to feed 2 tensioners.

SUBSEA TENSION

1,500 bar/21,750 psi

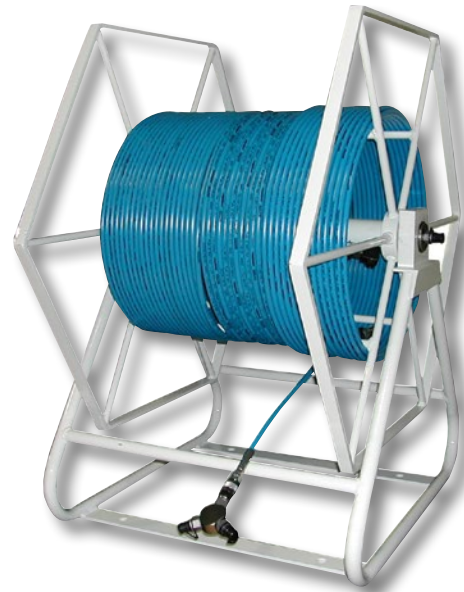

Hose reel stand complete with tensioner down line for offshore equipment use.

2008548		Female Coupling: Quick-connect, push-in female coupling with locking collar. Used on 1,500 bar tensioners hoses. G 1/4" Female Thread.
2001772		Male Coupling: Quick-connect, push-in male nipple. Used on 1,500 bar tensioners and pumps. G 1/4" Female Thread

Hoses come standard with recessed female coupler type (2008548). Flat Face couplers available upon request.







SPLITTERS & SPREADERS

3/8" COUPLERS

700 bar/10,000 psi



9764

9670		Tee adapter. For installing gauge between pump and hose coupling. Has 1/4" and 3/8" NPTF female and 3/8" NPTF male ports.
9799		Optional metal dust cap (hose half)
9797		Optional metal dust cap (pump/tool half)
9798 (male coupler)		Male (hose) half coupler (with No. 9800 dust cap). 3/8" NPTF.
9796 (female coupler)		Female (pump/tool) half coupler (with No. 9800 dust cap). 3/8" NPTF.
9800		Dust cap for male or female 3/8" NPTF half couplers.

IJ100 HYDRAULIC HOSE ASSEMBLY (AMERICAS & ASIA)

No. 9764 – Hose assembly consisting of 9767 (6' hose), 1/4" I.D. polyurethane with 9798 hose half coupler and 9800 dust cap assembly. Complies to MHI Standard IJ100 (2:1 Burst).

CE HYDRAULIC HOSE ASSEMBLY (EUROPE)

No. 9764E – Hose assembly consisting of 9767E (2m hose), 6mm I.D. polyurethane with 9798 hose half coupler and 9800 dust cap assembly. Complies to CE Standards (4:1 Burst over Nominal pressure ratio).

Note: Not for ENS Series Nut Splitter



For ENS NUT SPLITTER (TOPSIDE)

Hose assembly, 6mm I.D. polyurethane with 251410 hose coupler (1/4"). Complies to CE Standards (4:1 Burst over Nominal pressure ratio).

HHASH070001 - 3m Hose Assembly

HHASH070002 - 6m Hose Assembly.

For ENS Subsea Nut Splitters, see page 104.

9040 9040E		Gauge for 700 bar; 10,000 psi hand pumps. 9040 has psi as primary unit. 9040E has bar as primary unit.
9042DG		700 bar, 10,000 psi gauge for torque wrench applications. Custom scale enables the following units to be displayed: lb-ft or Nm

See page 114 for gauge calibration services.

STANDARD HYDRAULIC OIL

- For dependable performance of all your hydraulic pumps and cylinders.
- Contains foam suppressant additives and has a high viscosity index.

FLAME-OUT® 220 FIRE RESISTANT HYDRAULIC FLUID*

- Contains anti-rust, anti-foam and anti-sludge additives.
- Provides fire resistant protection.

(Note: Will burn if heat source is extreme enough. Will not, however, propagate the flame and is self-extinguishing when there is no ignition source.)

- Provides maximum lubrication and heat transfer.
- Offers a wider operating temperature range.
- No need to change seals in your equipment. Just drain the standard oil and replace it with Flame-Out® 220.

LOW TEMPERATURE OIL

Provides smooth, reliable operation in the coldest climate conditions.

HYDRAULIC FLUIDS

Standard, Flame Out®, Biodegradable and Low Temperature

BIODEGRADABLE HYDRAULIC FLUID

- Biodegradable, non-toxic fluid withstands moderate to severe operating conditions; provides excellent protection against rust.
- Offers superior anti-wear properties, has excellent multi-metal compatibility.

Developed to meet stringent performance requirements and satisfy growing environmental needs for hydraulic fluids which are readily biodegradable and non-toxic. Depending on the contamination or degradation levels which might be present in used fluid, small amounts of this substance, if spilled, will not affect ground water or the environment. This fluid has been tested against EPA 560/6-82-003 and OECD 301 for biodegradability, and toxicity has been tested against EPA 560/6-82-002 and OECD 203: 1-12. Not recommended for operation in temperatures below -7°C (20°F) or above 71°C (160°F). Recommended storage temperatures not below -23°C (-10°F) or above 77°C (170°F).

Specifications and Dimensional Data

Description	Grade (ASTM)	Specific Gravity @ 60°F (16°C)	Color (ASTM)	Flash Point		Fire Point		Pour Point		Viscosity			Foam Test (ASTM)
				°C	°F	°C	°F	°C	°F	SUS @ 38°C (100°F)	SUS @ 99°C (210°F)	Index min.	
Standard Oil	215	.88	2.0	204	400	221	430	-34	-30	215	48	100	Pass
Flame-Out®	220	.91	Light Amber	260	500	288	550	-26	-15	220	55	140	Pass
Biodegradable	-	.92	2.0	224	432	NA*	NA*	30	-22	183	53	213	Pass
Low Temp.	-	.87	6.5 (Red)	180	356	204	399	45	-48	183	52	190	Pass

Ordering Information

Order No.	Description	Quantity
9636	Standard Oil	0.9l 1 qt. (57 cu. in.)
9637	Standard Oil	3.8l 1 gal. (231 cu. in.)
9638	Standard Oil	9.5l 2-1/2 gal. (577 cu. in.)
9616	Standard Oil	208l 55 gal.
9639	Flame-Out®	3.8l 1 gal. (231 cu. in.)
9640	Flame-Out®	9.5l 2-1/2 gal. (577 cu. in.)
9645	Biodegradable	3.8l 1 gal. (231 cu. in.)
9646	Biodegradable	9.5l 2-1/2 gal. (577 cu. in.)
9647	Low Temp.	3.8l 1 gal. (231 cu. in.)



For additional technical information or to order a Material Safety Data Sheet call 1-800-477-8326 or go to www.spxboltingsystems.com.

FLANGE MANAGEMENT SYSTEMS

INTRODUCTION

FLANGEPRO provides a fully featured Flange Management System, maximizing the control of the Flange Register, allowing comprehensive and consistent operation of all flange break, make-up and inspection processes or commissioning, operations and turnarounds/shutdown applications.

WHY IS FLANGE INTEGRITY SO IMPORTANT?

Flange Management Systems can help address elements of SEMS, SEMS II, and RP 75, such as:

- Maintaining key information on flanged joints, leak testing, and controlled bolting bolt load calculations and methods.
- Documentation of operating procedures for controlled bolting processes.
- Help maintain mechanical integrity of piping assets.

Flange Management Systems can help address KP4 requirements:

- Help track flange records for ageing assets and maintain a documented record of their condition.

Flange Management Systems provides a system to help manage hydrocarbon-containing equipment from experiencing a hydrocarbon release.



FLANGE INTEGRITY MANAGEMENT SYSTEMS



A **3 year** study on the impact of leaking pipe flanges showed a major refinery averaged **630** leaks per year resulting in **380,000** pounds of volatile organic compounds (VOC) being released into the atmosphere. Estimated monetary losses from fines, materials, and labor charges averaged **\$440K** per year (not including production losses)*.

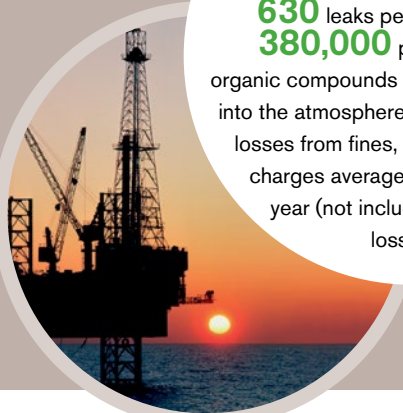

What's it worth to help prevent a catastrophic event?

- The Deepwater Horizon accident resulted in the loss of eleven lives and the overall cost was several billion dollars.
- The Piper Alpha accident cost the loss of 167 lives and changed the face of the North Sea O&G industry entirely.
- A high consequence event that occurred in a California refinery which resulted when a 4inch 300# gasket failed due to improper tightening. The refinery reported that consequential damages due to production loss, fines, and rework were in excess of \$500M*.

Our Flange Management Systems helps to:

- Mitigate & Avoid high consequence events
- Extend the life of an asset
- Maintain expected performance
- Manage Risk

(* Source: 2014 AFPM Reliability & Maintenance Conference)

FLANGE MANAGEMENT SYSTEMS

PRODUCT FEATURES



MULTIPLE PROJECTS

A centralized repository to capture, store and visualize multiple project or asset related information.



CLOUD PLATFORM

Internet-based global delivery of integrity systems to support both regional and international project execution and governance.



ASSET IDENTIFICATION

Rapid operations using barcoding and RFID for identification of physical and paper assets to automate business processes and improve accuracy.



CONFIGURABILITY /FLEXIBILITY

Our software is very flexible and can be extensively customized to mirror your organizational process and procedures.



ISO 27001

Our Data Centers are all ISO 27001 and 9001 accredited and operated at tier 3+ equivalent levels, ensuring you receive the highest standard of service.

Product Features	Personal	Professional	Enterprise
Core Features			
Cloud-based service with full resilience	Standard	Standard	Standard
Adviser Bolt Load Calculation Tool	Standard	Standard	Standard
Flange Management System	Standard	Standard	Standard
Inspection & Leak Test Planning System	Standard	Standard	Standard
Configurable Integrity Management Platform	Standard	Standard	Standard
All Upgrades / Software Maintenance	Standard	Standard	Standard
Easy Data Out Policy	Standard	Standard	Standard
Priority Access to Technical Assurance Centre		Limited	Standard
Collaboration			
Multi-user collaboration		Standard	Standard
Offline / Desktop Application			Standard
Hardware Integrity Kit Rental	Optional	Optional	Optional
Floating License Option			Optional
Named Users to Floating License Max Ratio		1:1	1:2
Back to Back License Option			1:1
Feature Packs		Optional	Standard
TAR - Project Management Module		Optional	Standard
TAG - Tag production and workflow system		Optional	Standard

Due to ongoing development work the product features may change

FLANGE MANAGEMENT SYSTEMS

FLANGEPRO BENEFITS

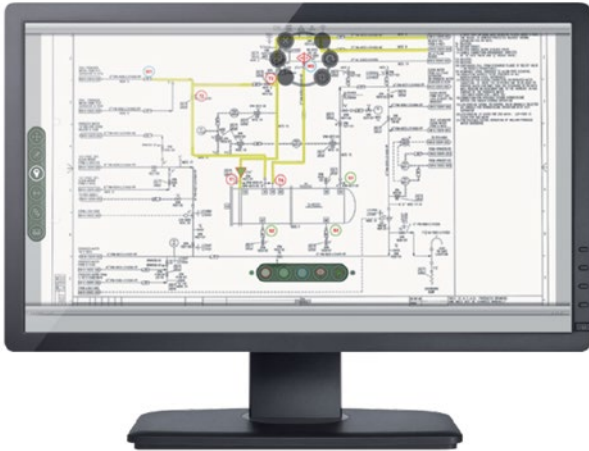

FLANGEPRO

FlangePro provides a fully featured Flange Management System, maximizing the control of the flange register, allowing comprehensive and consistent operation of all flange break, make-up and inspection processes for commissioning, operations and turnarounds/shutdown applications.

Built upon our unique and highly flexible Integrity Management System platform, FlangePro can be used in many different fields, project phases (Pre-Bid, On Site Work, Pre-Work and Completion Handover) and for many different service lines and activities, such as;

- Flange Management
- Equipment & Inventory Management
- Personnel management
- Service, Inspection and Process Management
- Shutdown Project Management
- Pre-Commissioning Completions Management
- Leak Test planning
- On-demand version allows licensing for specific short term projects

Product Features:

- Multiple Projects
- Asset Identification
- Secure Cloud Platform
- Configurability/Flexibility

Visit spxbolting.com for more details

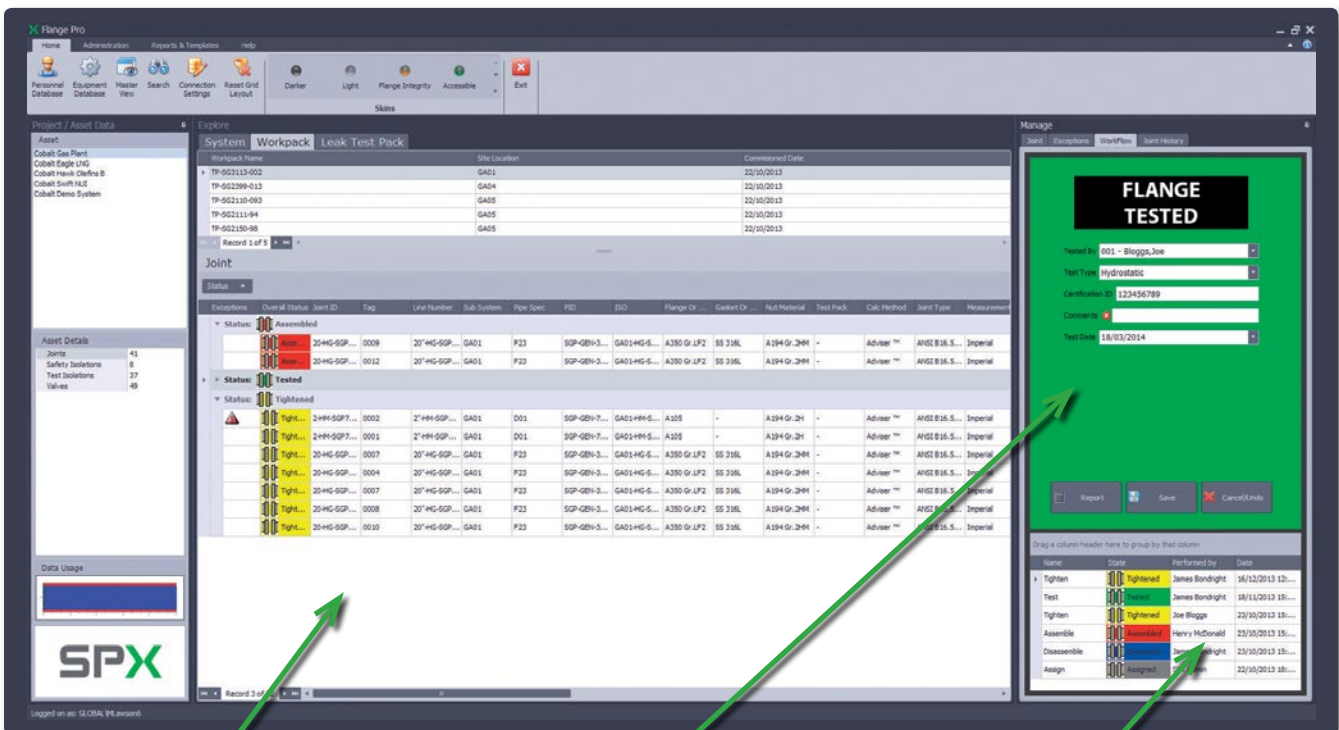

Sort workpacks/activities by status for ease of management

Visual workflow status matching any tagging process adopted

Full history of workflow/activities is recorded against the safety critical artifact and the activity pack it is held on.

ADVISER BOLT LOAD CALCULATOR

The adviser software considers many years of bolt working experience, where data has been channeled into a single computer software program. Bolt tightening data, procedures and recommendations for standard, non-standard and specialty joints makes adviser an invaluable tool to any industry.

The Adviser software package includes:

- Tightening data for BS1560, MSS SP44, API 6A and 17D flanged joints.
- Encompasses standard flanges, wafer check valves, spade and spacers, and swivel flange assemblies.
- Torque data and tensioning tool pressures for both Subsea and Topsides applications.
- Bolt extension calculations.
- Tightening procedures and Torque sequences.
- Joint specific recommendations for improved integrity.
- Large database of bolt materials.
- Large database of bolt lubricants.
- Dimensional data of flanges.
- Recommended bolt lengths.
- Simple user interface with 'Windows' look and feel.
- New bolt materials and lubricants can be added!

BOLT LOAD CALCULATOR ADVISER

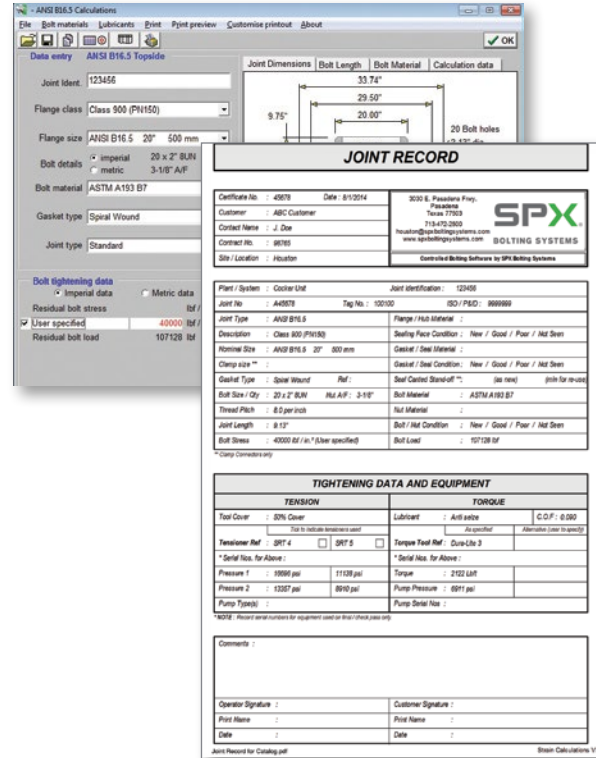

Visit the Apple AppStore for mobile applications

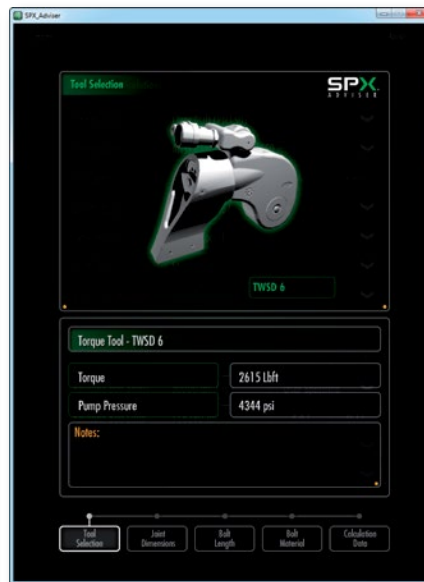

TRAINING

SPX FLOW Bolting Systems offer a range of courses covering joint integrity and flange management to industry recognized standards. All of our instructors have many years' experience in the joint integrity/flange management sector most of which have spent considerable time in a hands on role actually doing the job that they are now training others to do. Our instructors have nationally recognized teaching qualifications which reinforce the quality of the training programs that we offer.

Our courses contain a mix of both theoretical and practical elements providing a positive learning experience for the learner. We have purpose built training facilities around the globe which house the latest in flange management tooling and associated equipment and in which learners are encouraged by our Instructors to embrace all aspects of Health and Safety and to strive for a right first time approach to all joint integrity



applications. Courses can be delivered in a variety of formats including:

- Industry Approved training
- Well established in-house programs
- Bespoke options tailored to a client's requirement including SPX Flow Bolting tool maintenance, Adviser Software, etc

SPX FLOW Bolting Systems are an ECITB and API approved training provider.

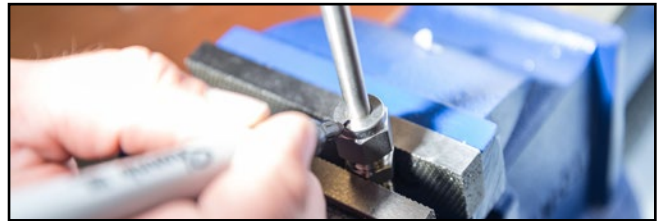

Engineering Construction Industry Training Board

APPROVED PROVIDER

ECITB APPROVED TRAINING

The ECITB has approved the following specific courses which are derived from the new Mechanical Joint Integrity and Small Bore Tubing Technical Training Standards.

- MJ10 - Hand Torque Bolted Connection Techniques – one day duration
- MJ18 - Hydraulically Tension Bolted Connection Techniques – one day duration
- MJ19 - Hydraulically Torque Bolted Connection Techniques – 1.5 days duration
- MJ10, 18 & 19 - Hydraulically Torque and Tension Bolted Connection Techniques – 2.5 days duration
- SBT01 Assemble and Install Small Bore Tubing with Twin Ferrule Mechanical Grip Fittings – 2 days duration

TECHNICAL TESTS

Technical Testing with an associated ECITB certificate of achievement plays a key role in validating an individual's skill, ability and job knowledge in a specific task area. Each test consists of a knowledge test and practical activity test against identified test criteria.

- There are five ECITB approved Technical Tests covering mechanical joint integrity and two covering Small Bore Tubing
- TMJI10 Dismantle, Assemble and Hand Torque Flanged Joints

- TMJI11 Dismantle, Assemble and Hand Torque Clamp Connectors
- TMJI18 Dismantle, Assemble and Tensioning Bolted Connections (Hydraulic Tensioning)
- TMJI 19 Dismantle, Assemble and Hydraulically Torque Flanged Joints
- TMJI 20 Dismantle, Assemble and Hydraulically Torque Clamp Connector Joints
- TSBT 01 Assemble and Install small bore tubing assemblies- Twin Ferrule
- TSBT 02 Disassemble and reinstall small bore tubing assemblies

ECITB courses and technical tests can be delivered at:

- SPX FLOW UK ECITB approved training and testing centers
- SPX FLOW Houston, TX, USA ECITB approved training and testing centers
- SPX FLOW Global Training facilities – subject to approval via SPX Training UK and ECITB
- Client Site UK – subject to approval via SPX FLOW Training UK.
- Client Site Global - subject to approval via SPX FLOW Training UK and ECITB



AMERICAN PETROLEUM INSTITUTE - APPROVED TRAINING

As an API-U approved training provider SPX FLOW can offer a two day course covering the assembly, tightening and disassembly of bolted connections. This course includes in depth practical instruction on the safe and effective use of both hand and hydraulic bolt tightening equipment.

This SPX FLOW API approved training course can be delivered at:

- SPX FLOW global training facilities
- Client Site Global – subject to approval via SPX FLOW Training UK.

API-U is dedicated to providing excellence in petroleum industry training. Because API has access to the largest pool of subject experts in the industry, API-U programs are taught by the best trainers who utilize today's innovative methods. The practical knowledge gained from API-U training enables participants to maintain professional competency.

Proud Provider



Upward Knowledge™

ADDITIONAL COURSE OFFERINGS

SPX FLOW ADVISOR – controlled bolting software

SPX FLOW FLANGEPRO – joint monitoring software

Service and Maintenance of SPX FLOW products



IOSH Managing Safely

IOSH Working Safely



RENTAL, CALIBRATION & SERVICE CENTERS

SPX FLOW Rental Service Centers offer full range of hydraulic torque wrenches, topside tensioners, subsea tensioners, nut splitters, pump units and ancillary equipment all available 24/7 to meet our customers needs.

All SPX FLOW Bolting Systems Service Centers offer calibration services for all hydraulic torque wrenches, torque pump units and tensioner pump units. Please contact your local SPX FLOW Service Center for details and pricing.





HOUSTON, TEXAS

- Located in Pasadena, TX near the O&G, Refinery and Petrochemical market
- Full Rental Inventory
- Training Facilities
- Calibration
- Repair
- 24/7 Availability



ABERDEEN, SCOTLAND

- Near key North Sea Offshore customers
- Rental Inventory
- Training Facilities



PERTH, AUSTRALIA

- Serves SE Asia customers
- Rental Inventory
- Training Facilities



OTHER LOCATIONS

- Corpus Christi, TX USA
- Gonzales, LA USA
- Sulphur, LA USA
- Ashington, UK
- Eyselshoven, Netherlands
- Singapore
- Shanghai, China

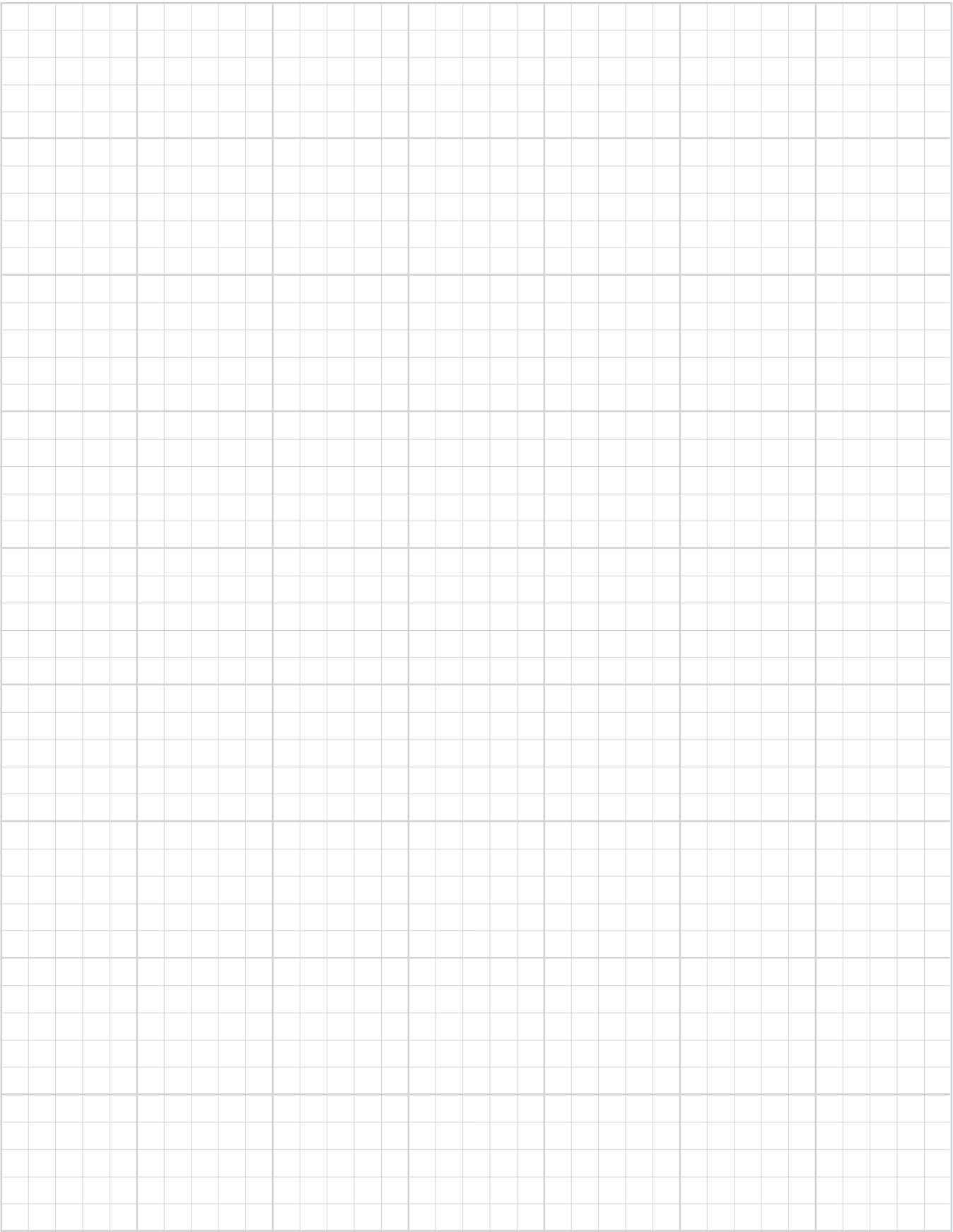

RESOURCES

Page
**MEASUREMENTS/
SPECIFICATIONS...118-125**
Conversion Formulas
Reference Tables



Page
SPX FLOW BOLT TENSIONERS...126-127
How it works

Page
HYDRAULIC BOLTING SAFETY...128-129



Page
APPLICATION DATA SHEET...130

Page
MANUFACTURING STANDARDS...132

Page
**POWERTHON™ LIFETIME
WARRANTY...133**



Page
CUSTOM PRODUCTS...134-135



MEASUREMENTS / SPECIFICATIONS

Conversion Formulas

Decimal & Millimeter Equivalents

	DECIMALS	MILLIMETERS		DECIMALS	MILLIMETERS
1/64	.015625	0.397	33/64	.515625	13.097
1/32	.03125	0.794	17/32	.53125	13.494
3/64	.046875	1.191	35/64	.546875	13.891
1/16	.0625	1.588	9/16	.5625	14.288
5/64	.078125	1.984	37/64	.578125	14.684
3/32	.09375	2.381	19/32	.59375	15.081
7/64	.109375	2.778	39/64	.609375	15.478
1/8	.1250	3.175	5/8	.6250	15.875
9/64	.140625	3.572	41/64	.640625	16.272
5/32	.15625	3.969	21/32	.65625	16.669
11/64	.171875	4.366	43/64	.671875	17.066
3/16	.1875	4.763	11/16	.6875	17.463
13/64	.203125	5.159	45/64	.703125	17.859
7/32	.21875	5.556	23/32	.71875	18.256
15/64	.234375	5.953	47/64	.734375	18.653
1/4	.2500	6.350	3/4	.7500	19.050
17/64	.265625	6.747	49/64	.765625	19.447
9/32	.28125	7.144	25/32	.78125	19.844
19/64	.296875	7.541	51/64	.796875	20.241
5/16	.3125	7.938	13/16	.8125	20.638
21/64	.328125	8.334	53/64	.828125	21.034
11/32	.34375	8.731	27/32	.84375	21.431
23/64	.359375	9.128	55/64	.859375	21.828
3/8	.3750	9.525	7/8	.8750	22.225
25/64	.390625	9.922	57/64	.890625	22.622
13/32	.40625	10.319	29/32	.90625	23.019
27/64	.421875	10.716	59/64	.921875	23.416
7/16	.4375	11.113	15/16	.9375	23.813
29/64	.453125	11.509	61/64	.953125	24.209
15/32	.46875	11.906	31/32	.96875	24.606
31/64	.484375	12.303	63/64	.984375	25.003
1/2	.5000	12.700	1	1.000	25.400

1 mm = .03937"
 .001" = .0254 mm

SI* Conversion Formulas

APPROXIMATE CONVERSION

MULTIPLY SI* UNIT	BY CONVERSION FACTOR	TO GET OR MULTIPLY NON-SI UNIT	BY CONVERSION FACTOR	TO GET SI* UNIT
LENGTH				
Millimeter (mm)	X 0.03937	= inch	X 25.4	= mm (1 inch = 25.4 mm exactly)
Centimeter (cm) 10 mm	X 0.3937	= inch	X 2.54	= cm
Meter (m) 1000 mm	X 3.28	= foot	X 0.305	= m
meter (m)	X 1.09	= yard	X 0.914	= m
kilometer (km) 1000 m	X 0.62	= mile	X 1.61	= km
AREA				
millimeter ² (mm ²)	X 0.00155	= inch ²	X 645	= mm ²
centimeter ² (cm ²)	X 0.155	= inch ²	X 6.45	= cm ²
meter ² (m ²)	X 10.8	= foot ²	X 0.0929	= m ²
meter ² (m ²)	X 1.2	= yard ²	X 0.836	= m ²
hectare (ha) 10,000 m ²	X 2.47	= acre	X 0.405	= ha
kilometer ² (km ²)	X 0.39	= mile ²	X 2.59	= km ²
VOLUME				
centimeter ³ (cm ³)	X 0.061	= inch ³	X 16.4	= cm ³
liter (L)	X 61	= inch ³	X 0.016	= L
milliliter (mL)	X 0.034	= oz-liq	X 29.6	= mL (1 mL = 1 cm ³)
liter (L) 1000 mL	X 1.06	= quart	X 0.946	= L
liter (L)	X 0.26	= Gallon	X 3.79	= L
meter ³ (m ³) 1000 L	X 1.3	= yard ³	X 0.76	= m ³
MASS				
Gram (g)	X 0.035	= ounce	X 28.3	= g
kilogram (kg) 1000 g	X 2.2	= pound	X 0.454	= kg
metric ton (t) 1000 kg	X 1.1	= ton (short)	X 0.907	= t
FORCE (N = kg • m/s²)				
Newton (N)	X 0.225	= pound	X 4.45	= N
kilonewton (kN)	X 225	= pound	X 0.00445	= kN
TORQUE				
newton meter (Nm)	X 8.9	= lb. in.	X 0.113	= Nm
newton meter (Nm)	X 0.74	= lb. ft.	X 1.36	= Nm
PRESSURE (Pa = N/m²)				
kilopascal (kPa)	X 4.0	= in. H ₂ O	X 0.249	= kPa
kilopascal (kPa)	X 0.30	= in. Hg	X 3.38	= kPa
kilopascal (kPa)	X 0.145	= psi	X 6.89	= kPa
megapascal (MPa)	X 145	= psi	X 0.00689	= MPa
bar	X 14.5	= psi	X 0.0680	= bar
POWER (w = J/s)				
kilowatt (kw)	X 1.34	= hp	X 0.746	= kw
kilowatt (kw)	X 0.948	= Btu/s	X 1.055	= kw
watt (w)	X 0.74	= ft. lb/s	X 1.36	= w
TEMPERATURE				
$^{\circ}\text{C} = (^{\circ}\text{F} - 32) \div 1.8$ $^{\circ}\text{F} = (^{\circ}\text{C} \times 1.8) + 32$				
FLOW				
cu cm/min	X 0.061	= cu in/min	X 16.4	= cu cm/min
liters/min	X 0.2642	= GPM	X 3.785	= liters/min

* System International (Modern Metric System)

MEASUREMENTS / SPECIFICATIONS

Conversion Formulas

TWSD Square Drive Hydraulic Torque Wrench Pressure - Torque Conversion Chart

Pump Pressure		Torque Output									
		TWSD1		TWSD3		TWSD6		TWSD11		TWSD25	
PSI	BAR	lb.-ft.	Nm	lb-ft	Nm	lb-ft	Nm	lb-ft	Nm	lb-ft	Nm
1,200	83	156	211	368	499	722	979	1,313	1,779	2,940	3,984
1,400	97	182	247	430	582	843	1,142	1,532	2,075	3,430	4,648
1,600	110	208	282	491	666	963	1,305	1,750	2,372	3,920	5,312
1,800	124	234	317	553	749	1,084	1,468	1,969	2,668	4,410	5,976
2,000	138	260	352	614	832	1,204	1,631	2,188	2,965	4,900	6,640
2,200	152	286	388	675	915	1,324	1,795	2,407	3,261	5,390	7,304
2,400	165	312	423	737	998	1,445	1,958	2,626	3,558	5,880	7,967
2,600	179	338	458	798	1,082	1,565	2,121	2,844	3,854	6,370	8,631
2,800	193	364	493	860	1,165	1,686	2,284	3,063	4,151	6,860	9,295
3,000	207	390	528	921	1,248	1,806	2,447	3,282	4,447	7,350	9,959
3,200	221	416	564	982	1,331	1,926	2,610	3,501	4,744	7,840	10,623
3,400	234	442	599	1,044	1,414	2,047	2,773	3,720	5,040	8,330	11,287
3,600	248	468	634	1,105	1,498	2,167	2,937	3,938	5,337	8,820	11,951
3,800	262	494	669	1,167	1,581	2,288	3,100	4,157	5,633	9,310	12,615
4,000	276	520	705	1,228	1,664	2,408	3,263	4,376	5,930	9,800	13,279
4,200	290	546	740	1,289	1,747	2,528	3,426	4,595	6,226	10,290	13,943
4,400	303	572	775	1,351	1,830	2,649	3,589	4,814	6,522	10,780	14,607
4,600	317	598	810	1,412	1,914	2,769	3,752	5,032	6,819	11,270	15,271
4,800	331	624	846	1,474	1,997	2,890	3,915	5,251	7,115	11,760	15,935
5,000	345	650	881	1,535	2,080	3,010	4,079	5,470	7,412	12,250	16,599
5,200	359	676	916	1,596	2,163	3,130	4,242	5,689	7,708	12,740	17,263
5,400	372	702	951	1,658	2,246	3,251	4,405	5,908	8,005	13,230	17,927
5,600	386	728	986	1,719	2,330	3,371	4,568	6,126	8,301	13,720	18,591
5,800	400	754	1,022	1,781	2,413	3,492	4,731	6,345	8,598	14,210	19,255
6,000	414	780	1,057	1,842	2,496	3,612	4,894	6,564	8,894	14,700	19,919
6,200	427	806	1,092	1,903	2,579	3,732	5,057	6,783	9,191	15,190	20,583
6,400	441	832	1,127	1,965	2,662	3,853	5,221	7,002	9,487	15,680	21,247
6,600	455	858	1,163	2,026	2,746	3,973	5,384	7,220	9,784	16,170	21,911
6,800	469	884	1,198	2,088	2,829	4,094	5,547	7,439	10,080	16,660	22,575
7,000	483	910	1,233	2,149	2,912	4,214	5,710	7,658	10,377	17,150	23,238
7,200	496	936	1,268	2,210	2,995	4,334	5,873	7,877	10,673	17,640	23,902
7,400	510	962	1,304	2,272	3,078	4,455	6,036	8,096	10,970	18,130	24,566
7,600	524	988	1,339	2,333	3,162	4,575	6,199	8,314	11,266	18,620	25,230
7,800	538	1,014	1,374	2,395	3,245	4,696	6,363	8,533	11,563	19,110	25,894
8,000	552	1,040	1,409	2,456	3,328	4,816	6,526	8,752	11,859	19,600	26,558
8,200	565	1,066	1,444	2,517	3,411	4,936	6,689	8,971	12,156	20,090	27,222
8,400	579	1,092	1,480	2,579	3,494	5,057	6,852	9,190	12,452	20,580	27,886
8,600	593	1,118	1,515	2,640	3,578	5,177	7,015	9,408	12,749	21,070	28,550
8,800	607	1,144	1,550	2,702	3,661	5,298	7,178	9,627	13,045	21,560	29,214
9,000	621	1,170	1,585	2,763	3,744	5,418	7,341	9,846	13,341	22,050	29,878
9,200	634	1,196	1,621	2,824	3,827	5,538	7,505	10,065	13,638	22,540	30,542
9,400	648	1,222	1,656	2,886	3,910	5,659	7,668	10,284	13,934	23,030	31,206
9,600	662	1,248	1,691	2,947	3,993	5,779	7,831	10,502	14,231	23,520	31,870
9,800	676	1,274	1,726	3,009	4,077	5,900	7,994	10,721	14,527	24,010	32,534
10,000	689	1,300	1,762	3,070	4,160	6,020	8,157	10,940	14,824	24,500	33,198
10,153	700	1,320	1,789	3,117	4,223	6,112	8,282	11,107	15,050	24,874	33,705

TWLC Low Clearance Hydraulic Torque Wrench Pressure - Torque Conversion Chart

Pump Pressure		Torque Output									
		TWLC2		TWLC4		TWLC8		TWLC15		TWLC30	
PSI	BAR	lb-ft	Nm	lb-ft	Nm	lb-ft	Nm	lb-ft	Nm	lb-ft	Nm
1,200	83	189	256	477	646	954	1,293	1,782	2,415	3,456	4,683
1,400	97	221	299	557	754	1,113	1,508	2,079	2,817	4,032	5,463
1,600	110	252	341	636	862	1,272	1,724	2,376	3,220	4,608	6,244
1,800	124	284	384	716	970	1,431	1,939	2,673	3,622	5,184	7,024
2,000	138	315	427	795	1,077	1,590	2,154	2,970	4,024	5,760	7,805
2,200	152	347	470	875	1,185	1,749	2,370	3,267	4,427	6,336	8,585
2,400	165	378	512	954	1,293	1,908	2,585	3,564	4,829	6,912	9,366
2,600	179	410	555	1,034	1,400	2,067	2,801	3,861	5,232	7,488	10,146
2,800	193	441	598	1,113	1,508	2,226	3,016	4,158	5,634	8,064	10,927
3,000	207	473	640	1,193	1,616	2,385	3,232	4,455	6,037	8,640	11,707
3,200	221	504	683	1,272	1,724	2,544	3,447	4,752	6,439	9,216	12,488
3,400	234	536	726	1,352	1,831	2,703	3,663	5,049	6,841	9,792	13,268
3,600	248	567	768	1,431	1,939	2,862	3,878	5,346	7,244	10,368	14,049
3,800	262	599	811	1,511	2,047	3,021	4,093	5,643	7,646	10,944	14,829
4,000	276	630	854	1,590	2,154	3,180	4,309	5,940	8,049	11,520	15,610
4,200	290	662	896	1,670	2,262	3,339	4,524	6,237	8,451	12,096	16,390
4,400	303	693	939	1,749	2,370	3,498	4,740	6,534	8,854	12,672	17,171
4,600	317	725	982	1,829	2,478	3,657	4,955	6,831	9,256	13,248	17,951
4,800	331	756	1,024	1,908	2,585	3,816	5,171	7,128	9,659	13,824	18,732
5,000	345	788	1,067	1,988	2,693	3,975	5,386	7,425	10,061	14,400	19,512
5,200	359	819	1,110	2,067	2,801	4,134	5,602	7,722	10,463	14,976	20,293
5,400	372	851	1,152	2,147	2,909	4,293	5,817	8,019	10,866	15,552	21,073
5,600	386	882	1,195	2,226	3,016	4,452	6,033	8,316	11,268	16,128	21,854
5,800	400	914	1,238	2,306	3,124	4,611	6,248	8,613	11,671	16,704	22,634
6,000	414	945	1,280	2,385	3,232	4,770	6,463	8,910	12,073	17,280	23,415
6,200	427	977	1,323	2,465	3,339	4,929	6,679	9,207	12,476	17,856	24,195
6,400	441	1,008	1,366	2,544	3,447	5,088	6,894	9,504	12,878	18,432	24,976
6,600	455	1,040	1,409	2,624	3,555	5,247	7,110	9,801	13,280	19,008	25,756
6,800	469	1,071	1,451	2,703	3,663	5,406	7,325	10,098	13,683	19,584	26,537
7,000	483	1,103	1,494	2,783	3,770	5,565	7,541	10,395	14,085	20,160	27,317
7,200	496	1,134	1,537	2,862	3,878	5,724	7,756	10,692	14,488	20,736	28,098
7,400	510	1,166	1,579	2,942	3,986	5,883	7,972	10,989	14,890	21,312	28,878
7,600	524	1,197	1,622	3,021	4,093	6,042	8,187	11,286	15,293	21,888	29,659
7,800	538	1,229	1,665	3,101	4,201	6,201	8,402	11,583	15,695	22,464	30,439
8,000	552	1,260	1,707	3,180	4,309	6,360	8,618	11,880	16,098	23,040	31,220
8,200	565	1,292	1,750	3,260	4,417	6,519	8,833	12,177	16,500	23,616	32,000
8,400	579	1,323	1,793	3,339	4,524	6,678	9,049	12,474	16,902	24,192	32,780
8,600	593	1,355	1,835	3,419	4,632	6,837	9,264	12,771	17,305	24,768	33,561
8,800	607	1,386	1,878	3,498	4,740	6,996	9,480	13,068	17,707	25,344	34,341
9,000	621	1,418	1,921	3,578	4,848	7,155	9,695	13,365	18,110	25,920	35,122
9,200	634	1,449	1,963	3,657	4,955	7,314	9,911	13,662	18,512	26,496	35,902
9,400	648	1,481	2,006	3,737	5,063	7,473	10,126	13,959	18,915	27,072	36,683
9,600	662	1,512	2,049	3,816	5,171	7,632	10,341	14,256	19,317	27,648	37,463
9,800	676	1,544	2,091	3,896	5,278	7,791	10,557	14,553	19,720	28,224	38,244
10,000	689	1,575	2,134	3,975	5,386	7,950	10,772	14,850	20,122	28,800	39,024
10,153	700	1,599	2,167	4,036	5,468	8,071	10,936	15,077	20,429	29,240	39,620

MEASUREMENTS / SPECIFICATIONS

Conversion Formulas

TWHC High Cycle Hydraulic Torque Wrench Pressure - Torque Conversion Chart

Pump Pressure		Torque Output							
		TWHC1		TWHC3		TWHC6		TWHC50	
PSI	BAR	lb-ft	Nm	lb-ft	Nm	lb-ft	Nm	lb-ft	Nm
1,200	83	170	230	376	510	726	984	6,360	8,618
1,400	97	198	268	439	595	847	1,148	7,420	10,054
1,600	110	226	306	502	680	968	1,312	8,480	11,491
1,800	124	254	345	564	765	1,089	1,476	9,540	12,927
2,000	138	283	383	627	850	1,210	1,640	10,600	14,363
2,200	152	311	421	690	935	1,331	1,804	11,660	15,799
2,400	165	339	460	753	1,020	1,452	1,967	12,720	17,236
2,600	179	367	498	815	1,105	1,573	2,131	13,780	18,672
2,800	193	396	536	878	1,190	1,694	2,295	14,840	20,108
3,000	207	424	574	941	1,275	1,815	2,459	15,900	21,545
3,200	221	452	613	1,004	1,360	1,936	2,623	16,960	22,981
3,400	234	480	651	1,066	1,445	2,057	2,787	18,020	24,417
3,600	248	509	689	1,129	1,530	2,178	2,951	19,080	25,854
3,800	262	537	728	1,192	1,615	2,299	3,115	20,140	27,290
4,000	276	565	766	1,254	1,700	2,420	3,279	21,200	28,726
4,200	290	593	804	1,317	1,785	2,541	3,443	22,260	30,163
4,400	303	622	842	1,380	1,870	2,662	3,607	23,320	31,599
4,600	317	650	881	1,443	1,955	2,783	3,771	24,380	33,035
4,800	331	678	919	1,505	2,040	2,904	3,935	25,440	34,472
5,000	345	707	957	1,568	2,125	3,025	4,099	26,500	35,908
5,200	359	735	996	1,631	2,210	3,146	4,263	27,560	37,344
5,400	372	763	1,034	1,693	2,295	3,267	4,427	28,620	38,780
5,600	386	791	1,072	1,756	2,380	3,388	4,591	29,680	40,217
5,800	400	820	1,110	1,819	2,465	3,509	4,755	30,740	41,653
6,000	414	848	1,149	1,882	2,550	3,630	4,919	31,800	43,089
6,200	427	876	1,187	1,944	2,635	3,751	5,083	32,860	44,526
6,400	441	904	1,225	2,007	2,720	3,872	5,247	33,920	45,962
6,600	455	933	1,264	2,070	2,805	3,993	5,411	34,980	47,398
6,800	469	961	1,302	2,132	2,890	4,114	5,575	36,040	48,835
7,000	483	989	1,340	2,195	2,975	4,235	5,738	37,100	50,271
7,200	496	1,017	1,379	2,258	3,060	4,356	5,902	38,160	51,707
7,400	510	1,046	1,417	2,321	3,144	4,477	6,066	39,220	53,144
7,600	524	1,074	1,455	2,383	3,229	4,598	6,230	40,280	54,580
7,800	538	1,102	1,493	2,446	3,314	4,719	6,394	41,340	56,016
8,000	552	1,130	1,532	2,509	3,399	4,840	6,558	42,400	57,453
8,200	565	1,159	1,570	2,572	3,484	4,961	6,722	43,460	58,889
8,400	579	1,187	1,608	2,634	3,569	5,082	6,886	44,520	60,325
8,600	593	1,215	1,647	2,697	3,654	5,203	7,050	45,580	61,762
8,800	607	1,243	1,685	2,760	3,739	5,324	7,214	46,640	63,198
9,000	621	1,272	1,723	2,822	3,824	5,445	7,378	47,700	64,634
9,200	634	1,300	1,761	2,885	3,909	5,566	7,542	48,760	66,070
9,400	648	1,328	1,800	2,948	3,994	5,687	7,706	49,820	67,507
9,600	662	1,356	1,838	3,011	4,079	5,808	7,870	50,880	68,943
9,800	676	1,385	1,876	3,073	4,164	5,929	8,034	51,940	70,379
10,000	689	1,413	1,915	3,136	4,249	6,050	8,198	53,000	71,816
10,153	700	1,435	1,944	3,184	4,314	6,142	8,323	53,809	72,912

Recommended Bolt Stresses for ANSI B16.5, BS1560 and MSS SP44 Flanges

Nom Bore	Flange Class					
	150 lb (PN20)	300 lb (PN50)	600 lb (PN100)	900 lb (PN150)	1,500 lb (PN250)	2,500 lb (PN420)
1/2" (15)	4 x 1/2" (M14)	4 x 1/2" (M14)	4 x 1/2" (M14)	4 x 3/4" (M20)	4 x 3/4" (M20)	4 x 3/4" (M20)
3/4 (20)	4 x 1/2" (M14)	4 x 5/8" (M16)	4 x 5/8" (M16)	4 x 3/4" (M20)	4 x 3/4" (M20)	4 x 3/4" (M20)
1" (25)	4 x 1/2" (M14)	4 x 5/8" (M16)	4 x 5/8" (M16)	4 x 7/8" (M24)	4 x 7/8" (M24)	4 x 7/8" (M24)
1-1/4" (32)	4 x 1/2" (M14)	4 x 5/8" (M16)	4 x 5/8" (M16)	4 x 7/8" (M24)	4 x 7/8" (M24)	4 x 1" (M27)
1-1/2" (40)	4 x 1/2" (M14)	4 x 3/4" (M20)	4 x 3/4" (M20)	4 x 1" (M27)	4 x 1" (M27)	4 x 1-1/8" (M30)
2" (50)	4 x 5/8" (M16)	8 x 5/8" (M16)	8 x 5/8" (M16)	8 x 7/8" (M24)	8 x 7/8" (M24)	8 x 1" (M27)
2-1/2" (65)	4 x 5/8" (M16)	8 x 3/4" (M20)	8 x 3/4" (M20)	8 x 1" (M27)	8 x 1" (M27)	8 x 1-1/8" (M30)
3" (80)	4 x 5/8" (M16)	8 x 3/4" (M20)	8 x 3/4" (M20)	8 x 7/8" (M24)	8 x 1-1/8" (M30)	8 x 1-1/4" (M33)
4" (100)	8 x 5/8" (M16)	8 x 3/4" (M20)	8 x 7/8" (M24)	8 x 1-1/8" (M30)	8 x 1-1/4" (M33)	8 x 1-1/2" (M39)
5" (125)	8 x 3/4" (M20)	8 x 3/4" (M20)	8 x 1" (M27)	8 x 1-1/4" (M33)	8 x 1-1/2" (M39)	8 x 1-3/4" (M45)
6" (150)	8 x 3/4" (M20)	12 x 3/4" (M20)	12 x 1" (M27)	12 x 1-1/8" (M30)	12 x 1-3/8" (M36)	8 x 2" (M52)
8" (200)	8 x 3/4" (M20)	12 x 7/8" (M24)	12 x 1-1/8" (M30)	12 x 1-3/8" (M36)	12 x 1-5/8" (M42)	12 x 2" (M52)
10" (250)	12 x 7/8" (M24)	16 x 1" (M27)	16 x 1-1/4" (M33)	16 x 1-3/8" (M36)	12 x 1-7/8" (M48)	12 x 2-1/2" (M64)
12" (300)	12 x 7/8" (M24)	16 x 1-1/8" (M30)	20 x 1-1/4" (M33)	20 x 1-3/8" (M36)	16 x 2" (M52)	12 x 2-3/4" (M70)
14" (350)	12 x 1" (M27)	20 x 1-1/8" (M30)	20 x 1-3/8" (M36)	20 x 1-1/2" (M39)	16 x 2-1/4" (M56)	
16" (400)	16 x 1" (M27)	20 x 1-1/4" (M33)	20 x 1-1/2" (M39)	20 x 1-5/8" (M42)	16 x 2-1/2" (M64)	
18" (450)	16 x 1-1/8" (M30)	24 x 1-1/4" (M33)	20 x 1-5/8" (M42)	20 x 1-7/8" (M48)	16 x 2-3/4" (M70)	
20" (500)	20 x 1-1/8" (M30)	24 x 1-1/4" (M33)	24 x 1-5/8" (M42)	20 x 2" (M52)	16 x 3" (M76)	
24" (600)	20 x 1-1/4" (M33)	24 x 1-1/2" (M39)	24 x 1-7/8" (M48)	20 x 2-1/2" (M64)	16 x 3-1/2" (M90)	
26" (650)	24 x 1-1/4" (M33)	28 x 1-5/8" (M42)	24 x 1-7/8" (M48)	20 x 2-3/4" (M70)		
28" (700)	28 x 1-1/4" (M33)	28 x 1-5/8" (M42)	28 x 2" (M52)	20 x 3" (M76)		
30" (750)	28 x 1-1/4" (M33)	28 x 1-3/4" (M45)	28 x 2" (M52)	20 x 3" (M76)		
32" (800)	28 x 1-1/2" (M39)	28 x 1-7/8" (M48)	28 x 2-1/4" (M56)	20 x 3-1/4" (M85)		
34" (850)	32 x 1-1/2" (M39)	28 x 1-7/8" (M48)	28 x 2-1/4" (M56)	20 x 3-1/2" (M90)		
36" (90)	32 x 1-1/2" (M39)	32 x 2" (M52)	28 x 2-1/2" (M64)	20 x 3-1/2" (M90)		

Recommended Bolt Stress

40,000 lbf/in²
 45,000 lbf/in²
 50,000 lbf/in²

The above stress levels are suitable for flanges with a minimum material yield stress of 30,000 lb/in² and bolt material grades ASTM A193 B7, B16, B7M and ASTM A320 L7, L43, L7M.

Information is used at the owner's discretion. All data is given in good faith and without acceptance of responsibility on the part of SPX FLOW.

MEASUREMENTS / SPECIFICATIONS

Reference Tables

Typical Co-Efficient Values For Bolt Lubricants

Manufacturer	Product	Coefficient of Friction
Acheson Colloids	Anti seize	0.09
	DAG580 (Dry Lubricant)	0.16
Belzona Molecular Ltd	HP anti seize	0.15
	Copperslip	0.09
Bostik Ltd	Never seez Std grade (NS160)	0.18
	Never seez Spl grade (NS165)	0.18
Castrol	Castrol Nucleol S202	0.08
	Spherol Castrol	0.13
Comma Oil & Chemicals	Copper Ease	0.14
Chemodex	Coppergrease	0.15
Chesterton International	Anti Seize (paste)	0.14
Dow Corning	Molykote Cu-7439	0.15
	Molykote 1000	0.11
	Molykote G-Rapid	0.08
	Molykote G-Rapid Plus	0.09
Fordec	Fordec Copper Anti seize	0.15
Ilex Lubricants	Coppercrest	0.14
Molyslip	Molyslip AS60	0.07
National Chemical Co	Thread Eze	0.18
	Copaslip	0.12
OKS	OKS 240	0.12
	OKS 250	0.08
K.S. Paul	Easyrun 100	0.08
	PBC	0.13
	PBC/D Lead Free	0.12
Rocol	516	0.18
	Rocol ASP	0.10
	Rocol J166	0.15
Silkolene	Rocol 797	0.16
	Silkease Copper	0.14
Sovereign Lubricants	Omega 99	0.13
	Omega 99N	0.09
	Omega 95	0.12
Swan Chemicals	Swanlube	0.12
James Walker	Walkers Anti seize No 203	0.15
Wessex Chemical Factors	WCF Anti Seize	0.15

MEASUREMENTS / SPECIFICATIONS

Torque Requirements for Imperial Bolts

IMPERIAL TORQUE (Values = lb-ft)

1/2"	3/8"	1/2"	5/8"	3/4"	7/8"	1"	1-1/8"	1-1/4"	1-3/8"	1-1/2"	1-5/8"	1-3/4"	1-7/8"	2"	2-1/4"	2-1/2"	2-3/4"	3"	3-1/4"	3-1/2"	3-3/4"
7/8"	1-1/16"	1-1/4"	1-1/8"	1-3/16"	2"	1-13/16"	1-1/8"	1-1/4"	2-3/16"	2-3/8"	2-9/16"	2-3/4"	2-15/16"	3-1/8"	3-1/2"	3-7/8"	4-1/4"	4-5/8"	5"	5-3/8"	5-3/4"
17	33	58	93	138	200	278	375	491	629	790	978	1,192	1,309	1,598	2,294	3,171	4,255	5,544	7,082	8,883	10,956
22	43	76	122	181	263	368	497	663	838	1,055	1,309	1,688	2,294	3,171	4,255	5,544	7,082	9,002	11,410	14,410	18,010
26	50	88	141	209	306	428	579	761	977	1,231	1,529	1,968	2,686	3,714	4,989	6,504	8,313	10,610	13,610	17,410	22,010
29	57	100	160	238	348	487	660	889	1,117	1,408	1,750	2,238	2,922	4,011	5,377	7,043	9,109	11,676	14,943	18,910	23,777
27	53	93	148	220	320	445	599	795	1,006	1,263	1,565	1,907	2,323	3,167	4,232	5,521	7,056	9,002	11,410	14,410	18,010
35	69	121	194	289	421	588	795	1,044	1,340	1,687	2,094	2,656	3,445	4,611	6,066	7,922	10,179	13,045	16,622	21,010	26,222
41	80	140	225	334	488	684	925	1,217	1,564	1,970	2,447	2,989	3,822	5,011	6,566	8,611	11,067	14,233	18,210	23,100	29,010
46	91	160	265	380	556	779	1,056	1,390	1,787	2,252	2,799	3,421	4,322	5,611	7,366	9,611	12,467	16,044	20,521	26,010	33,522
31	60	104	167	248	359	500	674	883	1,131	1,421	1,761	2,146	2,686	3,522	4,611	6,066	7,922	10,179	13,045	16,622	21,010
40	78	137	218	325	474	662	894	1,175	1,508	1,898	2,356	2,976	3,766	4,911	6,411	8,366	10,772	13,838	17,565	22,050	28,362
46	90	158	253	376	550	769	1,041	1,369	1,759	2,216	2,752	3,362	4,233	5,522	7,211	9,366	12,083	15,560	19,897	25,100	32,212
52	102	180	287	428	626	877	1,188	1,563	2,010	2,534	3,149	3,849	4,722	6,011	7,866	10,272	13,338	17,215	21,900	28,312	36,424
34	65	116	185	275	399	556	749	982	1,257	1,579	1,956	2,384	2,945	3,811	4,900	6,305	8,211	10,517	13,522	17,338	22,050
44	86	152	243	361	526	735	994	1,305	1,675	2,109	2,617	3,195	3,958	5,047	6,547	8,552	11,058	14,224	18,150	23,040	29,152
51	100	176	281	418	611	855	1,157	1,521	1,954	2,462	3,058	3,736	4,611	5,899	7,722	10,027	13,002	16,827	21,512	27,000	34,512
58	113	199	319	475	695	974	1,320	1,737	2,233	2,815	3,499	4,276	5,252	6,733	8,811	11,411	14,716	18,842	23,877	30,010	38,522

Torque values all shown in lb-ft

The torque values are for fully threaded UNC (up to 1")/UN8 stud bolts/heavy series nuts. Bolt Materials: ASTM A193 B7, B7M & B16; ASTM A320 L7, L7M & L43

METRIC TORQUE (Values = Nm)

1/2"	5/8"	3/4"	7/8"	1"	1-1/8"	1-1/4"	1-3/8"	1-1/2"	1-5/8"	1-3/4"	1-7/8"	2"	2-1/4"	2-1/2"	2-3/4"	3"	3-1/4"	3-1/2"	3-3/4"
7/8"	1-1/16"	1-1/4"	1-7/16"	1-5/8"	1-13/16"	2"	2-3/16"	2-3/8"	2-9/16"	2-3/4"	2-15/16"	3-1/8"	3-1/2"	3-7/8"	4-1/4"	4-5/8"	5"	5-3/8"	5-3/4"
23	45	79	126	187	271	377	508	666	863	1,071	1,326	1,616	2,316	3,183	4,276	5,564	7,089	8,894	10,959
30	58	103	165	245	357	499	674	885	1,136	1,430	1,775	2,167	3,110	4,299	5,769	7,517	9,602	12,044	14,854
35	68	119	191	283	415	580	785	1,032	1,325	1,669	2,073	2,533	3,642	5,036	6,764	8,818	11,271	14,144	17,451
39	77	136	217	323	472	660	895	1,178	1,514	1,909	2,373	2,899	4,172	5,773	7,758	9,983	12,940	16,244	20,047
37	72	126	201	298	434	603	812	1,064	1,364	1,712	2,122	2,586	3,704	5,107	6,843	8,902	11,358	14,231	17,533
47	94	164	263	392	571	797	1,078	1,415	1,817	2,287	2,839	3,465	4,977	6,878	9,229	12,026	15,363	19,270	23,766
56	108	190	305	453	662	927	1,254	1,650	2,121	2,671	3,318	4,053	5,826	8,058	10,821	14,109	18,034	22,629	27,920
62	123	217	346	515	754	1,056	1,432	1,885	2,423	3,053	3,795	4,638	6,673	9,237	12,443	16,191	20,703	25,988	32,076
42	81	141	226	336	487	678	914	1,197	1,533	1,927	2,388	2,910	4,168	5,746	7,698	10,015	12,779	16,008	19,724
54	106	186	296	441	643	898	1,212	1,593	2,045	2,573	3,194	3,899	5,600	7,738	10,383	13,530	17,284	21,678	26,737
62	122	214	343	510	746	1,043	1,411	1,856	2,385	3,004	3,731	4,558	6,554	9,065	12,174	15,873	20,288	25,458	31,410
71	138	244	389	580	849	1,189	1,611	2,119	2,725	3,436	4,269	5,219	7,509	10,392	13,964	18,215	23,292	29,238	36,085
46	88	157	251	373	541	754	1,016	1,331	1,704	2,141	2,652	3,232	4,630	6,385	8,553	11,127	14,188	17,768	21,917
60	117	206	329	489	713	997	1,348	1,769	2,271	2,859	3,548	4,332	6,221	8,597	11,537	15,032	19,204	24,087	29,707
69	136	239	381	567	828	1,159	1,569	2,062	2,649	3,338	4,146	5,065	7,282	10,071	13,527	17,635	22,542	28,286	34,902
79	153	270	433	644	942	1,321	1,790	2,355	3,028	3,817	4,744	5,797	8,342	11,546	15,516	19,384	25,880	32,487	40,094

Torque values all shown in Nm

MEASUREMENTS / SPECIFICATIONS

Torque Requirements for Metric Bolts

IMPERIAL TORQUE (Values = lb-ft)

Bolt Diameter Nut A/F	mm		M14	M16	M20	M24	M27	M30	M33	M36	M39	M42	M45	M48	M52	M56	M64	M70	M76	M85	M90
			22	24	30	36	41	46	50	55	60	65	70	75	80	85	95	100	110	120	130
Torque figures in this section will induce Residual Bolt Loads equivalent to the white/grey section in the Imperial Torque table on the previous page. These values are typical for clamp connectors	$\mu = 0.08$	18	32	59	97	141	207	286	389	508	657	822	1,026	1,261	1,744	2,465	3,240	4,199	5,463	6,767	9,046
	$\mu = 0.11$	24	42	77	127	167	272	377	512	670	866	1,086	1,354	1,688	2,305	3,262	4,299	5,587	7,290	9,046	11,863
	$\mu = 0.13$	27	48	89	147	215	316	437	594	779	1,005	1,261	1,572	1,939	2,679	3,794	5,005	6,512	8,508	10,566	13,612
	$\mu = 0.15$	31	55	101	167	245	359	498	676	887	1,144	1,443	1,791	2,210	2,855	3,863	5,071	6,678	8,873	11,663	14,474
Torque figures in this section will induce Residual Bolt Loads equivalent to the green section in the Imperial Torque table on the previous page.	$\mu = 0.08$	29	51	94	155	225	332	457	623	812	1,051	1,314	1,642	2,017	2,790	3,943	5,183	6,718	8,740	10,827	13,983
	$\mu = 0.11$	38	66	123	203	296	436	602	819	1,072	1,385	1,737	2,166	2,688	3,687	5,218	6,877	9,038	11,663	14,474	18,305
	$\mu = 0.13$	43	77	142	235	344	505	699	951	1,246	1,607	2,018	2,516	3,102	4,286	6,069	8,007	10,418	13,612	16,905	21,311
	$\mu = 0.15$	49	87	161	267	391	574	796	1,082	1,419	1,830	2,299	2,865	3,536	4,884	6,691	9,137	11,898	15,561	19,336	24,180
Torque figures in this section will induce Residual Bolt Loads equivalent to the yellow section in the Imperial Torque table on the previous page.	$\mu = 0.08$	32	57	105	174	253	373	504	701	914	1,182	1,479	1,847	2,269	3,139	4,436	5,831	7,556	9,832	12,180	15,603
	$\mu = 0.11$	42	75	138	228	333	490	677	922	1,206	1,588	1,994	2,437	3,001	4,148	5,671	7,737	10,055	13,121	16,283	20,549
	$\mu = 0.13$	49	86	159	264	387	568	786	1,069	1,401	1,809	2,270	2,830	3,490	4,821	6,527	8,744	11,271	14,514	18,018	22,173
	$\mu = 0.15$	55	98	181	300	440	646	895	1,217	1,596	2,058	2,587	3,223	3,978	5,494	7,784	10,279	13,386	17,507	21,753	27,243
Torque figures in this section will induce Residual Bolt Loads equivalent to the red section in the Imperial Torque table on the previous page.	$\mu = 0.08$	36	63	117	194	282	414	571	778	1,015	1,313	1,643	2,052	2,521	3,487	4,929	6,479	8,397	10,925	13,534	17,243
	$\mu = 0.11$	47	83	153	253	370	544	753	1,024	1,340	1,731	2,171	2,707	3,355	4,609	6,523	8,597	11,173	14,579	18,092	22,131
	$\mu = 0.13$	54	96	177	293	430	631	874	1,188	1,557	2,009	2,522	3,144	3,877	5,357	7,586	10,009	13,023	17,015	21,131	26,469
	$\mu = 0.15$	61	109	201	333	489	717	995	1,352	1,773	2,287	2,874	3,581	4,420	6,105	8,649	11,421	14,873	19,452	24,169	30,169

Torque values all shown in lb-ft

The torque values are for fully threaded coarse metric stud bolts/standard series nuts. Bolt Materials: ASTM A193 B7, B7M & B16; ASTM A320 L7, L7M & L43

METRIC TORQUE (Values = Nm)

Bolt Diameter Nut A/F	mm		M14	M16	M20	M24	M27	M30	M33	M36	M39	M42	M45	M48	M52	M56	M64	M70	M76	M85	M90
			22	24	30	36	41	46	50	55	60	65	70	75	80	85	95	100	110	120	130
Torque figures in this section will induce Residual Bolt Loads equivalent to the white/grey section in the Imperial Torque table on the previous page. These values are typical for clamp connectors	$\mu = 0.08$	24	43	80	132	191	226	369	511	694	908	1,174	1,472	1,836	2,262	3,125	4,423	5,829	7,575	9,984	12,265
	$\mu = 0.11$	33	57	104	172	226	401	591	816	1,110	1,453	1,878	2,355	2,937	3,617	4,999	7,075	9,324	12,118	15,813	19,624
	$\mu = 0.13$	37	65	121	199	292	428	628	885	1,209	1,609	2,179	2,736	3,411	4,206	5,811	8,228	10,856	14,125	18,455	22,920
	$\mu = 0.15$	42	75	137	226	332	487	717	1,019	1,467	1,924	2,481	3,117	3,884	4,794	6,622	9,381	12,388	16,132	21,098	26,216
Torque figures in this section will induce Residual Bolt Loads equivalent to the green section in the Imperial Torque table on the previous page.	$\mu = 0.08$	39	69	127	210	305	450	620	845	1,101	1,425	1,782	2,226	2,735	3,783	5,346	7,027	9,108	11,950	14,679	18,679
	$\mu = 0.11$	52	89	167	275	401	591	816	1,110	1,453	1,878	2,355	2,937	3,617	4,999	7,075	9,324	12,118	15,813	19,624	24,624
	$\mu = 0.13$	58	104	193	319	466	685	948	1,289	1,769	2,349	3,036	3,736	4,541	5,476	7,551	10,009	13,023	17,015	21,131	26,469
	$\mu = 0.15$	66	118	218	362	530	778	1,079	1,487	1,994	2,601	3,218	3,947	4,791	5,850	8,029	10,744	14,013	18,152	23,069	28,850
Torque figures in this section will induce Residual Bolt Loads equivalent to the yellow section in the Imperial Torque table on the previous page.	$\mu = 0.08$	43	77	142	236	343	506	683	950	1,239	1,603	2,005	2,504	3,076	4,256	6,014	7,906	10,247	13,330	16,514	20,914
	$\mu = 0.11$	57	102	187	309	451	664	918	1,250	1,635	2,112	2,649	3,304	4,069	5,624	7,960	10,490	13,633	17,790	22,077	27,627
	$\mu = 0.13$	66	117	216	358	525	770	1,066	1,449	1,900	2,453	3,078	3,837	4,732	6,536	9,256	12,213	15,892	20,763	25,785	32,069
	$\mu = 0.15$	75	133	245	407	597	876	1,213	1,650	2,164	2,790	3,508	4,370	5,393	7,449	10,554	13,936	18,149	23,736	29,493	36,550
Torque figures in this section will induce Residual Bolt Loads equivalent to the red section in the Imperial Torque table on the previous page.	$\mu = 0.08$	49	85	159	263	382	561	774	1,055	1,376	1,780	2,228	2,782	3,418	4,728	6,683	8,784	11,385	14,812	18,350	23,169
	$\mu = 0.11$	64	113	207	343	502	738	1,021	1,388	1,817	2,347	2,943	3,670	4,522	6,249	8,844	11,656	15,149	19,767	24,529	30,529
	$\mu = 0.13$	73	130	240	397	583	856	1,185	1,611	2,111	2,724	3,419	4,263	5,257	7,263	10,285	13,570	17,657	23,069	28,850	35,914
	$\mu = 0.15$	83	148	273	451	663	972	1,349	1,833	2,404	3,101	3,897	4,855	5,993	8,277	11,726	15,485	20,165	26,373	32,769	40,469

Torque values all shown in Nm

SPX FLOW BOLT TENSIONERS HOW IT WORKS

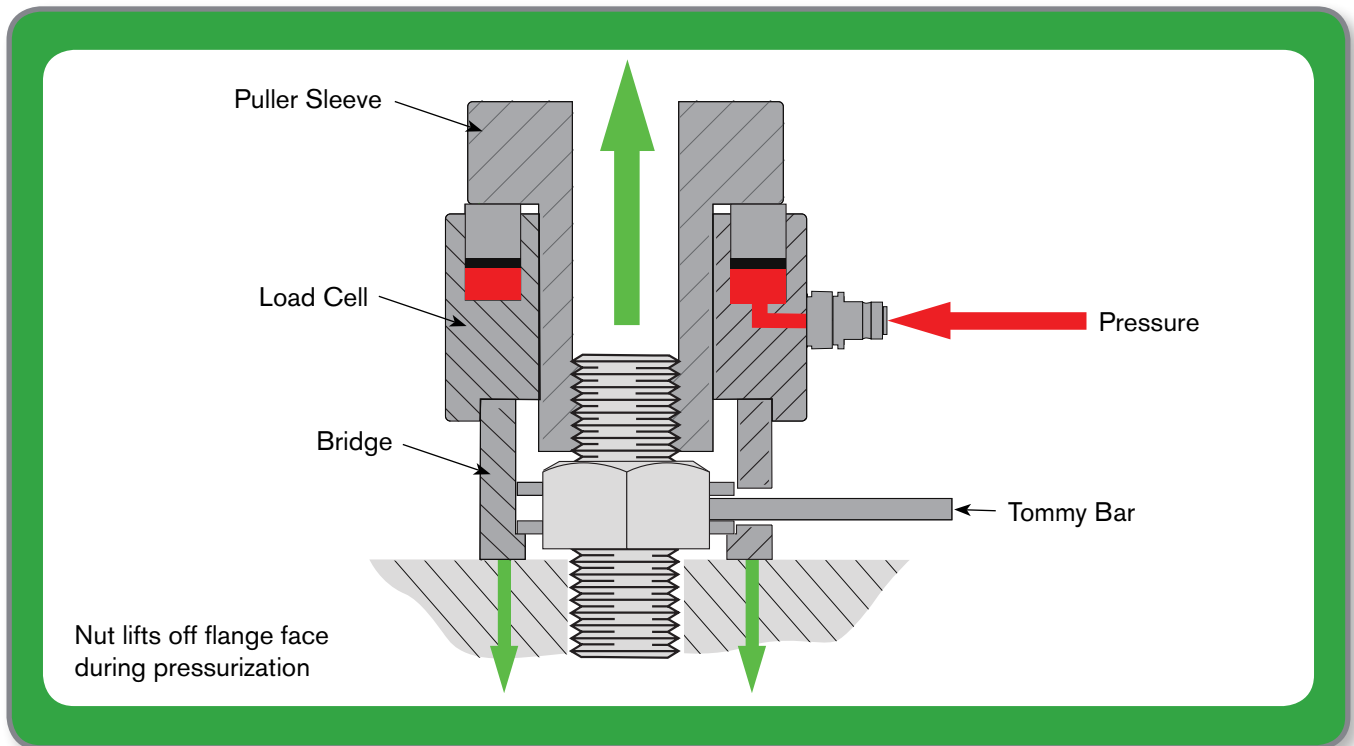

Hydraulic tensioning is a method of stretching the stud in lieu of turning the nut as with traditional torquing. Each stud has a yield strength, and can be stretched as a form of tightening, eliminating galling and friction, and the need for lubricants.

Hydraulic Bolt Tensioners are used to provide the most accurate residual bolt load and uniform compression on the gasket. The bolt tensioner can be applied to a single bolt or any number of bolts depending upon access and the application. However, to give the most accurate residual load, a bolt tensioner should be placed on, ideally, 50% or 100% of the studs. (See graphic next page).

The load cell and adapter kit is placed over the top of each stud and nut. The puller is then threaded onto the stud above the nut and sits flush against the hydraulic load cell. Each tool is interconnected with hoses to insure all tools are pressurized simultaneously.

The hydraulic pump unit is activated and as pressure builds throughout the system. The load cell starts to extend and push against the puller, stretching the stud. As this continues, the nut lifts off the flange face. Once the desired pressure is met, the pump valve is closed to

hold the pressure. The socket ring is turned down using a tommy bar so the nut is now back sitting flush on the flange face. Once all the nuts have been turned down, the pump pressure is released and the stud attempts to return to its normal state thus creating a clamping force on the gasket. Since all bolts are tightened at the same time, this provides a uniform load across the joint.

TYPICAL 50% TENSIONER LAYOUT



Assemble tensioners to 50% of the bolts.
Apply 'Pressure 1' as indicated on the bolt tensioning data sheet.
Tighten down the nuts using a tommy bar.



Move the tensioners to the remaining 50% of the bolts and apply 'Pressure 2' as indicated on the bolt tensioning data sheet.
Tighten down the nuts using a tommy bar.

Release the system pressure and repeat the reapplication of the pressure and tightening of the nuts a further twice.

TYPICAL 50% FLANGE SET-UP

For proper tensioner tool fit, there must be ample stud above the nut

50% Bolt Tensioning

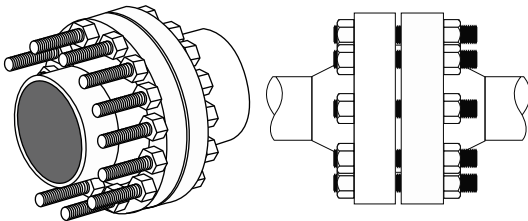

100% Bolt Tensioning

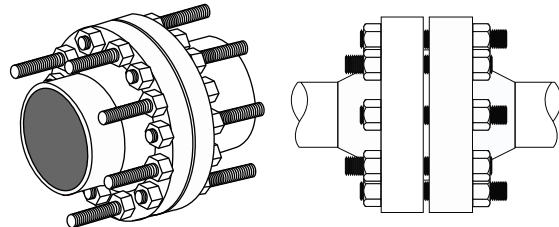

For topside applications, make sure the stud extends a minimum of one bolt diameter above the nut. For subsea applications, refer to the SPX FLOW SST tool selection chart for dimension.

100% Tensioning Set-up for Subsea Tensioning

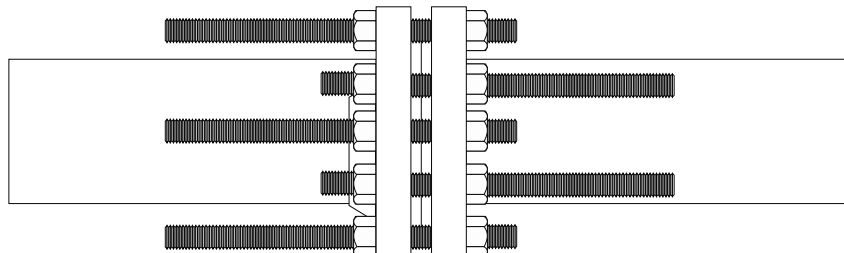

HYDRAULIC BOLTING SAFETY

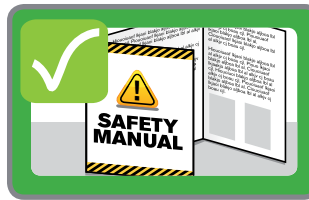

Read all instructions and safety warnings before using the pumps, tools and other equipment.

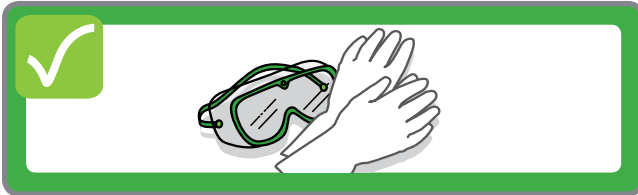

Wear appropriate Personal Protective Equipment (PPE).



Do not exceed the rated load of any pump, tool or component.

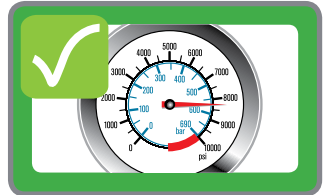

Inspect all components before use. Do not use damaged or worn components. Return to an Authorized Repair Center for repair or replacement.



Never alter internal relief valves.



Recognize system pressures. Do not use a 20,000 PSI pump on a system with 10,000 PSI components (hoses, fittings, valves, tools, etc.).

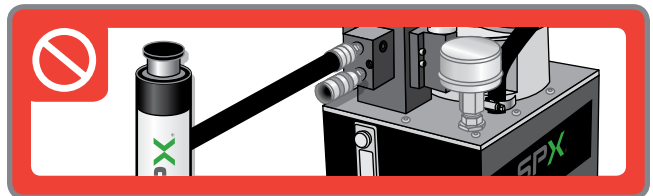

Do not use pumps designed for torque wrenches or tensioners for lifting.



Do not overfill pump reservoirs.



Use only high quality oil, like SPX FLOW Power Team hydraulic oil. Using the wrong fluid can lead to equipment damage and premature failure.



Do not use the same oil in all equipment and in all environments.

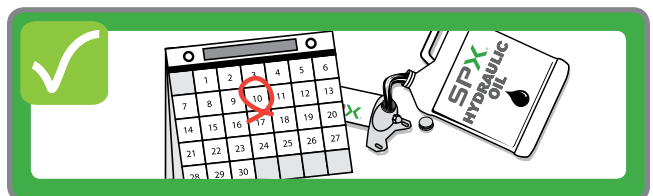

Change oil and/or filters at appropriate intervals.

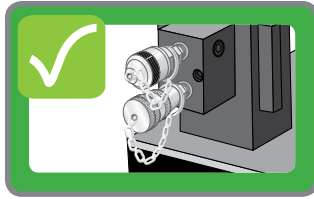
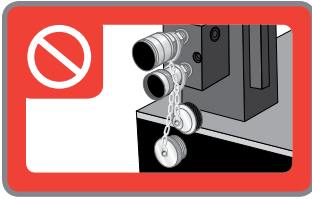

Do not operate a pump with couplers exposed or uncapped.

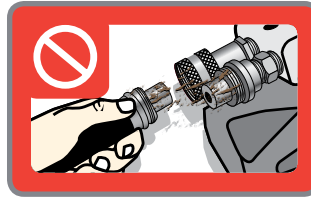

Clean both ends of the couplers before assembly.



Do not kink hydraulic hoses.



Replace damaged hoses immediately.



Keep equipment away from excessive temperatures. Do not weld next to unprotected equipment.



Keep couplers capped when not in use.



Do not drive over hoses or drop objects onto them.

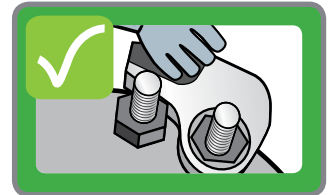
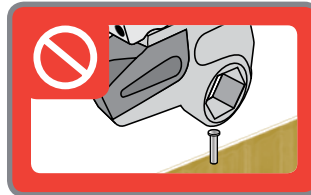

Only use tools for their intended purpose.

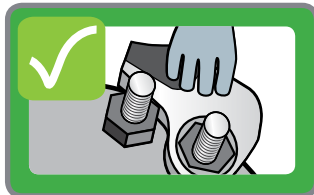

Keep hands clear of pinch points.

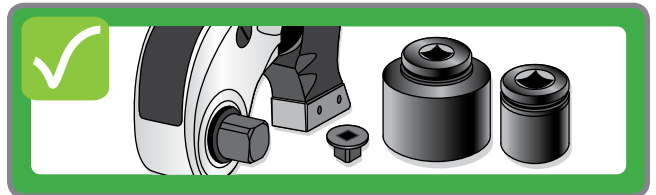

Only use high quality impact sockets and reducers with an appropriate load rating and safety factor.

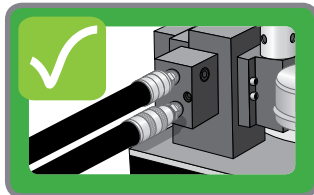
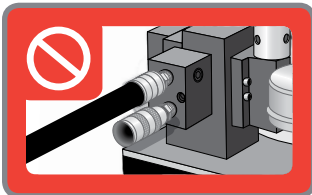

Always connect both torque wrench hoses to the pump. Do not operate with only one hose attached.

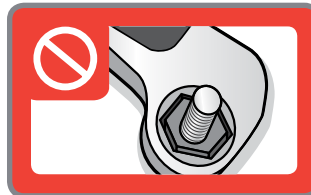

Use only the proper size sockets and links.

APPLICATION DATA SHEET

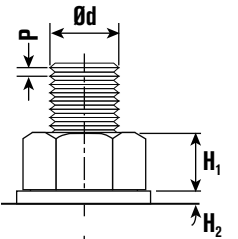
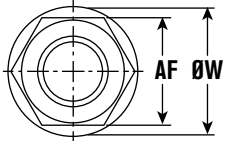
Nut Type 1		
$\varnothing d$	in/mm	
P (Pitch)	in/mm	
H1	in/mm	
H2	in/mm	
AF	in/mm	
$\varnothing W$	in/mm	

Nut Type 1

Circle "in" or "mm"

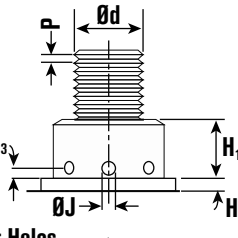
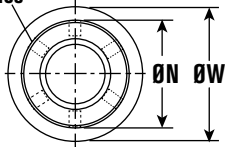
Nut Type 2		
$\varnothing d$	in/mm	
P (Pitch)	in/mm	
H1	in/mm	
H2	in/mm	
$\varnothing N$	in/mm	
$\varnothing W$	in/mm	
H3	in/mm	
$\varnothing J$	in/mm	
# of Holes	-	

Nut Type 2

Circle "in" or "mm"

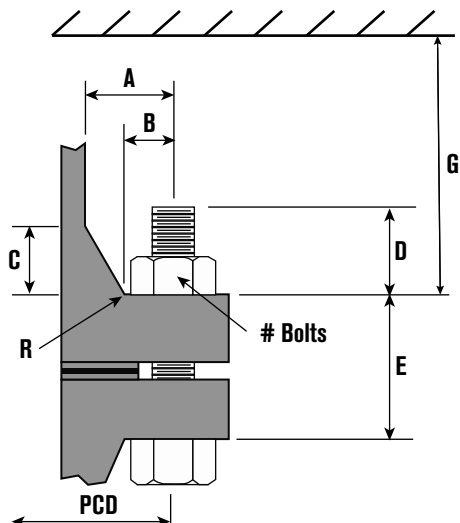
Application Dimensions		
		
A	in/mm	
B	in/mm	
C	in/mm	
D	in/mm	
E	in/mm	
G	in/mm	
R	in/mm	
# Bolts	-	
PCD	in/mm	
Additional Information		
Hot Dip Galvanized Threads : Y/N		

Circle "in" or "mm"

Load Requirements		
APPLIED HYDRAULIC LOAD (F_{HA})	N	
RESIDUAL BOLT LOAD (F_{RB})	N	

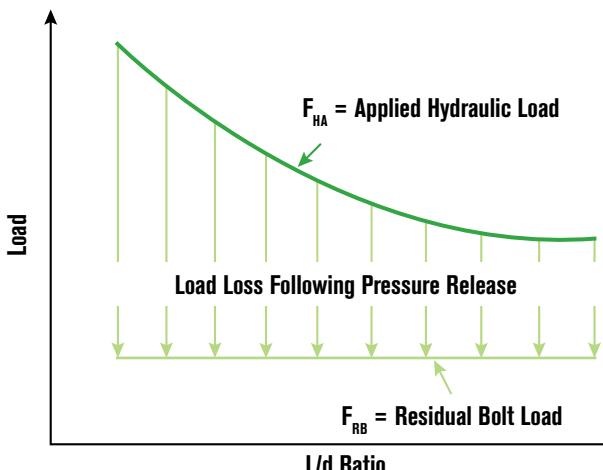

F_{HA} = Applied Hydraulic Load

Load Loss Following Pressure Release

F_{RB} = Residual Bolt Load

L/d Ratio

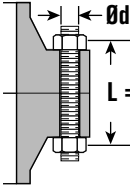

$\varnothing d$

L = Active Bolt Grip Length

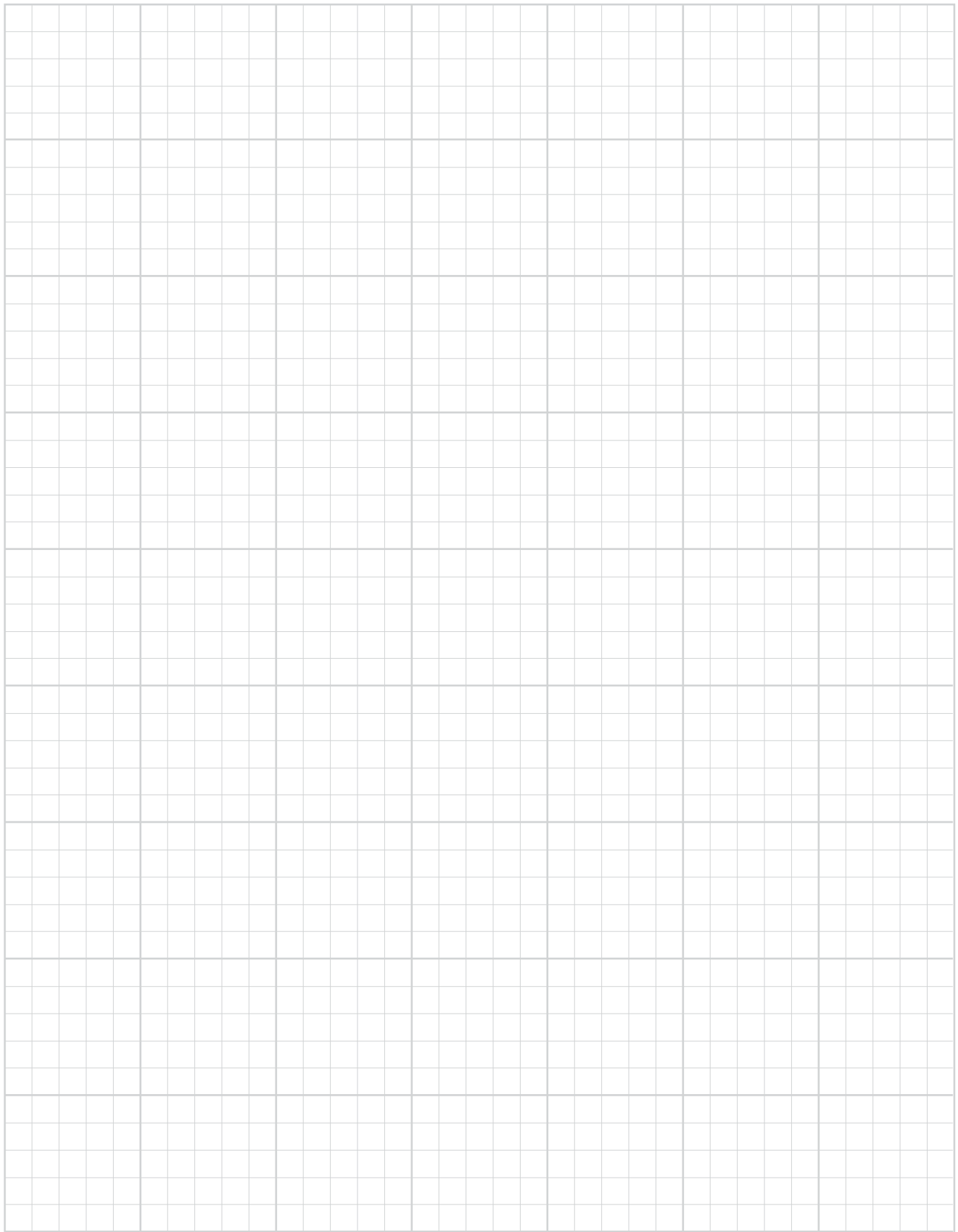

MEASUREMENTS / SPECIFICATIONS

Manufacturing Standards

Bolting Systems' commitment to quality is evident in everything we do, from raw material receipt to how we support our customers years after they purchase our products. Bolting Systems is registered to ISO 9001:2000 international quality standard. ISO 9001:2000 requires compliance with standards for management, administration, product development, manufacturing and continual improvement. Our Registration verifies that Bolting Systems has adopted and maintains documentation for processes ranging from suppliers to customers, inspection, handling, and training. ISO 9001 also requires periodic internal and external audits to ensure all aspects of work affecting quality control are monitored. This always has been, and will continue to be, our philosophy. That's our guarantee to you.

ASME B30.1

Some Bolting Systems tools are made using Power Team hydraulic cylinders which fully comply with the criteria set forth in the American Society of Mechanical Engineers standard ASME B30.1:

Our cylinders are designed to have a minimum of a 2-to-1 safety factor on typical material yield strength; Each cylinder is tested at 125 percent of rated pressure at full travel and is inspected to assure functionality and freedom from leaks.

ASME B40.1

Bolting Systems heavy-duty pressure gauges are designed in accordance with the recommendations set forth in the American Society of Mechanical Engineers standard ASME B40.1, Grade 1A or B.

CE MARK

Bolting Systems is committed to designing, manufacturing, and marketing products that meet or exceed the needs of the customers we serve. Bolting Systems supplies a Declaration of Incorporation or a Declaration of Conformity and CE Marking for products that conform with European Community Directives.

IJ100

Bolting Systems hoses meet the criteria set forth in the Material Handling Institute's specification #IJ100 for hydraulic hose. Under the procedures outlined in this standard, hydraulic hose shall:

1. Have an average minimum life of 30,000 cycles at full rated capacity.

2. Have a minimum burst pressure of at least twice the rated operating pressure.

- a. CE compliant hoses have a 4:1 burst rate over nominal operating pressure.

CSA

Where specified, Bolting Systems electric power pump assemblies meet the design, assembly, and test requirements of the Canadian Standards Association.

Note: If CSA certification is required, it must be requested at the time the pump is ordered.

NEMA

Where specified, Bolting Systems electric power pump assemblies meet the design, assembly, and test requirements of NEMA 12, a National Electrical Manufacturers' Association standard relating to electrical components used to resist moisture and dust.

BOLTING SYSTEMS PRODUCT DESIGN CRITERIA

All Bolting Systems brand hydraulic components are designed and/or tested to be safe for use at maximum operating pressures of 10,000 psi (690 bar) unless otherwise specifically noted.

QUALITY ASSURANCE

All of our products are subjected to quality checks during production. All materials are certified and have traceability to the mill. Before leaving the factory, all pressure containing products are tested to maximum working pressure to ensure on-the-job reliability. We have made every effort to include the latest specifications for our products in this catalog. Please call the Bolting Systems factory for the most current product specifications. The Bolting Systems Lifetime Powerthon™ Warranty is described in more detail on page 133 of this catalog.



POWERTHON™ LIFETIME WARRANTY

➤ Bolting Systems™

POWERTHON™ LIFETIME WARRANTY

“Bolting Systems” is a registered trademark of the SPX FLOW US, LLC. All Bolting Systems products and parts, with the exceptions noted below, are warranted against defects in materials and workmanship for the life of the product or part. (The life of the product or part is defined as that point in time when it no longer safely or properly functions due to normal wear). Inflatable jacks, chains, batteries, electric motors, gas engines, knives and cutter blades which are sold with Bolting Systems products are not covered by this warranty and instead are warranted as follows:

Inflatable Jacks and electronics are warranted against defects in materials and workmanship for a period of one year from date of purchase.

Consumable parts or accessories, including without limitation, chains, batteries, knives and cutter blades are warranted against defects in materials and workmanship for a period of one year from date of purchase.

All electric motors and gas engines are separately warranted by their respective manufacturer under the terms and conditions stated in their separate warranty.

The foregoing warranties do not cover ordinary wear and tear or any product or part that has been worn out, abused, heated, ground or otherwise altered, used for a purpose other than that for which it was intended or used in a manner inconsistent with any instructions regarding its use.

To qualify for warranty consideration, return the Bolting Systems product, freight prepaid, to a Bolting Systems authorized repair center or to the SPX FLOW factory. If any product or part manufactured by SPX FLOW found to be defective by SPX FLOW, in its sole judgment, SPX FLOW will, at its option, either repair or replace such defective product or part and return it via best ground transportation, freight prepaid. THIS REMEDY SHALL BE THE EXCLUSIVE REMEDY AVAILABLE FOR ANY DEFECTS IN THE PRODUCTS OR PARTS MANUFACTURED AND SOLD BY SPX FLOW OR FOR DAMAGES RESULTING FROM ANY OTHER CAUSE WHATSOEVER, INCLUDING WITHOUT LIMITATION, SPX FLOW'S NEGLIGENCE. SPX FLOW SHALL NOT, IN ANY EVENT, BE LIABLE TO ANY BUYER FOR CONSEQUENTIAL OR INCIDENTAL DAMAGES OF ANY KIND, WHETHER FOR DEFECTIVE OR NON-CONFORMING GOODS, NEGLIGENCE, ON THE BASIS OF STRICT LIABILITY OR FOR ANY OTHER REASON.

SPX FLOW's Warranty is expressly limited to persons who purchase Bolting Systems products or parts for the resale or for use in the ordinary course of the buyer's business.

THIS WARRANTY IS EXCLUSIVE, AND SPX FLOW MAKES NO OTHER WARRANTY OF ANY KIND WHATSOEVER, EXPRESSED OR IMPLIED, WITH RESPECT TO THE PRODUCTS MANUFACTURED AND SOLD BY IT, WHETHER AS TO MERCHANTABILITY, FITNESS FOR A PARTICULAR PURPOSE, OR ANY OTHER MATTER. No agent, employee, or representative of SPX FLOW has any authority to bind SPX FLOW to any affirmation, representation, or warranty concerning Bolting Systems products or parts, except as stated herein.

The purpose of this exclusive remedy shall be to provide the buyer with repair or replacement of products or parts manufactured by SPX FLOW found to be defective in materials or workmanship or negligently manufactured. This exclusive remedy shall not be deemed to have failed of its essential purpose so long as SPX FLOW is willing and able to replace said defective products or parts in the prescribed manner.



CUSTOM PRODUCTS AVAILABLE

SPANNER LINK & REACTION ROLLER



- For low height applications.
- For radially close applications
- Open ended spanner configurations
- Multi-plate applications for extreme low height applications
- Reaction 'roller' rolls around flange periphery during operation
- Manufactured to order

RING TENSIONER



- Custom tensioners designed to meet specific applications needs.

Contact your SPX FLOW representative for details on any of these custom products or we can develop a custom product for your application.

THREADED PISTON TENSIONERS



THREADED PISTON TENSIONERS FOR WIND TURBINE LOAD CHECKS

- Compact size
- High load
- Simple assembly
- Cost effective
- Light-weight and flexible
- Manufactured to order

TWHC ACCESSORIES



CUSTOM WRENCH ACCESSORIES AVAILABLE

Should our standard reaction device be unsuitable, SPX FLOW can design special reaction devices and drives upon request.

torque wrenches



10 - 33

tensioners



35 - 45

other tools



47 - 57

subsea tools



59 - 67

pumps 700 bar



69 - 89

pumps 1,500 bar



91 - 99

accessories



101 - 115

resources



117 - 135

SALES, SERVICE AND RENTAL CENTERS

USA

Houston, Texas USA

3106 E. Pasadena Frwy
Pasadena, TX 77503 USA
Tel: +1 713 472 2500
Fax: +1 713 472 2501

houston@spxboltingsystems.com

Corpus Christi, Texas USA

318 Centaurus Street
Corpus Christi, Texas 78405 USA
Tel: +1 361 371 6516
Fax: +1 361 687 2533

corpus.christi.SC@spxflow.com

Gonzales, Louisiana USA

3141 S. Darla Avenue
Gonzales, Louisiana 70737 USA
Tel: +1 225 774 0888
Fax: +1 225 450 2211

louisiana@spxboltingsystems.com

Sulphur, Louisiana USA

329 N. Beglis Parkway
Sulphur, Louisiana 70663 USA
Tel: +1 337 528 2500
Fax: +1 337 528 2800

louisiana@spxboltingsystems.com

UK

Aberdeen, UK

3 International View
ABZ Business Park
Aberdeen AB21 OBJ
Tel: +44 1224 756100

aberdeen@spxboltingsystems.com

Europe

Albert Huijsstraat 12
6471 WX Eygelshoven
The Netherlands
Tel: +31 45 567 8877

europe@spxboltingsystems.com

India

SPX Flow Technology (India) Pvt. Limited
Survey No. 275
Odhav, Ahmedabad - 382 415
Tel: +91-99099-85454
+91-97277-19950

india@spxboltingsystems.com

ENGINEERING, MANUFACTURING AND SUPPORT CENTERS

Rockford, Illinois USA

5885 11th Street
Rockford, IL 61109 USA
Tel: +1 815 874 5556
Fax: +1 800 288 7031

info@spxboltingsystems.com

SEA

20 Pioneer Crescent #06-01
West Park BizCentral
Singapore 628555
Tel: +65 6265 3343
Fax: +65 6265 6646

singapore@spxboltingsystems.com

China

No. 1568 Hua Shan Road
Treasury Building, 7th Floor
Shanghai 200052, China
Tel: +86 21 2208 5660/5659/5667
Fax: +86 21 2208 5682

china@spxboltingsystems.com

Australia

SPX Flow Technology Australia Pty Ltd
Quad 2, 6 Parkview Drive
Homebush Bay NSW 2127
Tel: +61 02 9763 4900
Fax: +61 02 9763 7888

ft.aus.cs@spxflow.com

Ashington, UK

Wansbeck Workspace
Rotary Parkway
Ashington
Northumberland NE63 8QZ

Global Technical Assistance, UK
+44 1670 850580

boltingsupport@spxflow.com

Distributed by:

Bolting Systems®

SPX FLOW, Inc. reserves the right to incorporate our latest design and material changes without notice or obligation.

Design features, materials of construction and dimensional data, as described in this bulletin, are provided for your information only and should not be relied upon unless confirmed in writing. Please contact your local sales representative for product availability in your region. For more information visit www.spxflow.com.

The green ">" and "X" are trademarks of SPX FLOW, Inc.

Bulletin: BS1904 Version: 04/2019

COPYRIGHT © 2019 SPX FLOW INC.